

Acct ID: 534020 MTL: 091W05D001100 Date: 2.25.24 Appr: JJS Prop Class: 551 RMV Prop Class: 451
 Situs: 11241 SHAFF RD SE AUMSVILLE OR 97325 MaSaNh: 07 06 000 Unit: 39709 Year: 2025

Last Date Appraised: 01/07/2025 Appraiser: MATT LORD Tag: Y N Tag info: 2026 - Tags/Permit (Outbuilding)
 Owner: WILSON, TRICIA Last Sales Date: 04/29/2021 Roll Type: R
 Cycle Tag Sales Verification Other: _____ Inspection level: 1 2 3 4 LCB TTO INSP AV: 138833
 RMV Land: 280160 RMV Imp: 174190 RMV Total: 454350 MAV: 78210 MSAV: 60623 SAV: 122017

Comment: 25-26: L3 MDL 1.7.25 TAG 24-007692

New Replacement GB @ 100%, 40A IN
26-27: New GB 36x36 AL2EX

Notations

RP/MS	Code	Description
RP	ZONED	FARM EFU ZONED

CWO 4/14/26 L4 farm use ok - Horses

OSDs

Count	Code	Description	RMV	Code Area	Exception
1	SAF	SA OSD - FAIR	40000	29555	0

Land

Site: 1 Code Area: 29555 Size: 1.00 Acres Use Code: 005 Zone: REST SAV Use: 011 Exception: 0
 Class: 4BDSS Value Source: Farm Homesite Description: FOUR BENCH DRY SPECIAL SOUTH RMV: 116020 Exception: Y N
 Adjustment(s): Fire Patrol: Description:
 Comments: Liability year - 2009

25-26 ADD SOIL

Site: 3 Code Area: 29555 Size: 1.07 Acres Use Code: 005 Zone: REST SAV Use: 011 Exception: 0
 Class: 4BDSS Value Source: Farm Use - EFU Description: FOUR BENCH DRY SPECIAL SOUTH RMV: 124140 Exception: Y N
 Adjustment(s): Fire Patrol: Description:
 Comments: Liability year - 1986 / 02950050 25-26 CORR SOIL

Improvements - Residence / Manufactured Structures

Bldg: 1 Code Area: 29555 Stat Class: 132 - Year Blt: 1950 Eff Year Blt: 1965 Sq.Ft: 1552 % Complete: 100.00
 Desc: Multi Story above grade Dimensions: RMV: 159010
 Func Obsc: 100 Econ %: 100 Other %: 100 Exception: 0 Adjust: Adjust RMV: 0

Floors

Type	Class	Display Group	Floor Size	Beds	Baths	Yr Blt	Eff Yr Blt	Inventory	Exception
First Floor	3 -	Finished	<u>1168</u> <u>1215</u>	2	FB-1	1950	1965	FP - 1, HVAC+, ROOF, KIT-, BATH - 1	Y N
Attic	3 -	Finished	<u>334</u> <u>396</u>	1	0	1950	1965	HVAC	Y N

Accessories

Description	Class	Size SqFt	Eff Yr Blt	RMV	Quantity	Exception
YARD IMPROVEMENTS AVERAGE	3	0	1965	13675	1	Y N

Improvements - Accessory Buildings

Bldg: 4 Code Area: 29555 Stat Class: 341 Year Blt: 1999 Eff Year Blt: 1999 Sq.Ft: 480 % Complete: 100.00
 Desc: Multi Purpose Shed (MP) Dimensions: 30x16 RMV: 5370
 Func Obsc: 100 Econ %: 100 Other %: 100 Exception: 0 Adjust: Adjust RMV: 0

Floors

Type	Class	Display Group	Floor Size	Beds	Baths	Yr Blt	Eff Yr Blt	Inventory	Exception
Multi-Purpose Bldg	5	Finished	480	0	0	1999	1999	FAIR	Y N

Accessories

Description	Class	Size SqFt	Eff Yr Blt	RMV	Quantity
No accessory data available					

Bldg: 5 Code Area: 29555 Stat Class: 353 Year Blt: 1960 Eff Year Blt: 2004 Sq.Ft: 1024 % Complete: 100.00
 Desc: Machine Shed (MS) Dimensions: 38x20 RMV: 9450
 Func Obsc: 100 Econ %: 100 Other %: 100 Exception: 0 Adjust: Adjust RMV: 0

Floors

Type	Class	Display Group	Floor Size	Beds	Baths	Yr Blt	Eff Yr Blt	Inventory	Exception
Machine Shed	5	Finished	1024	0	0	1960	2004	FAIR	Y N

Accessories

Description	Class	Size SqFt	Eff Yr Blt	RMV	Quantity
No accessory data available					

Bldg: 6 Code Area: 29555 Stat Class: 354 Year Blt: 1999 Eff Year Blt: 1999 Sq.Ft: 176 % Complete: 100.00
 Desc: Lean-to Light (LTL) Dimensions: 8x22 RMV: 360
 Func Obsc: 100 Econ %: 100 Other %: 100 Exception: 0 Adjust: Adjust RMV: 0

Floors

Type	Class	Display Group	Floor Size	Beds	Baths	Yr Blt	Eff Yr Blt	Inventory
Lean-to Light Duty	4	Finished	176	0	0	1999	1999	Exception: Y N

Accessories

Description	Class	Size SqFt	Eff Yr Blt	RMV	Quantity
No accessory data available					

Farm Notes

2025FARM

1/7/25: Inspected by MDL L3 during tags, farm use ok - cattle

351 GB S Fair 30x34 2025 100%.



New
 GB
 @ 100%.



SKETCH/AREA TABLE ADDENDUM

SUBJECT INFO

File No.: 534020 Parcel No.: 091W05D 01100
 Property Address: 11241 Shaff Rd SE
 City: Aumsville County: State: OR ZipCode: 97325
 Owner:
 Client: Client Address:
 Appraiser Name: Inspection Date:

SKETCH

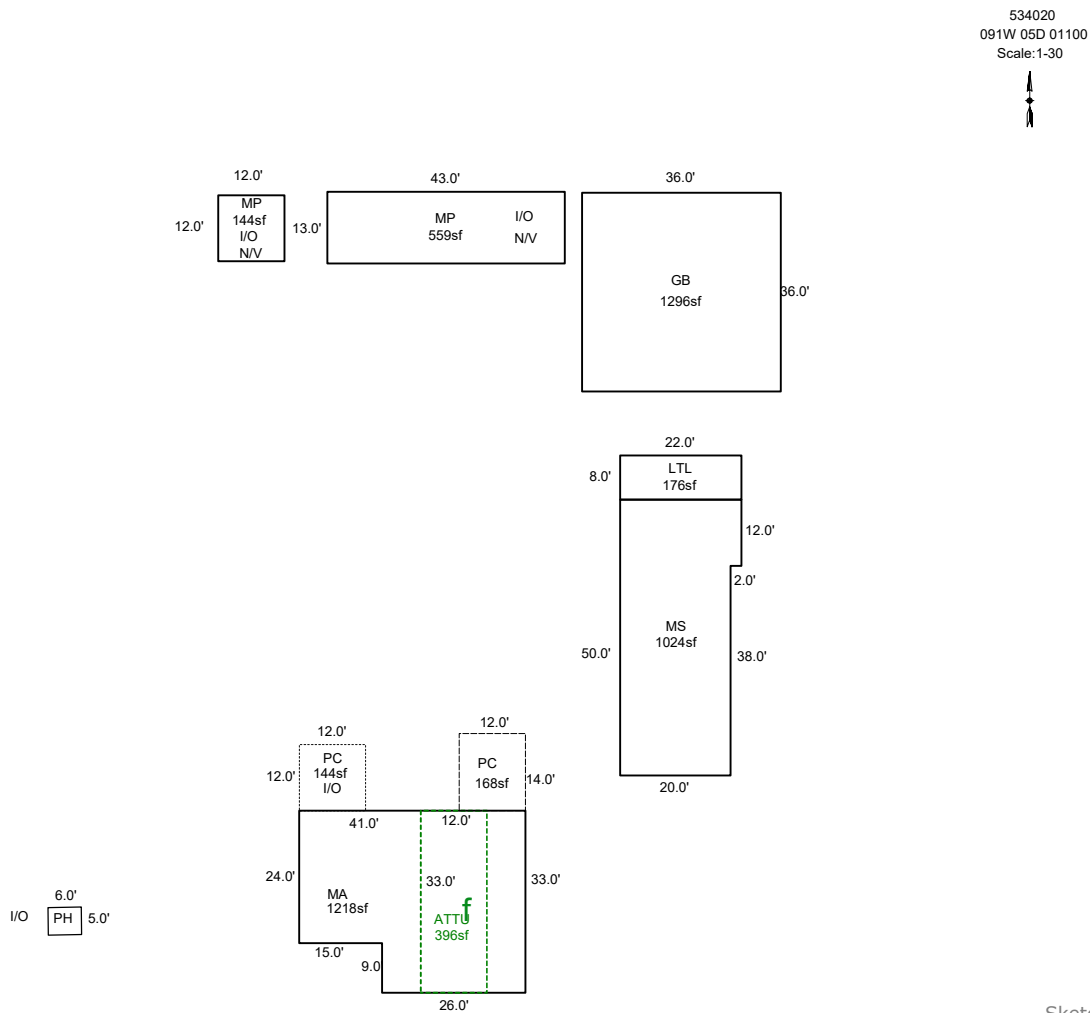

AREA CALCULATIONS SUMMARY

Code	Description	Factor	Net Size	Perimeter	Net Totals
GBA1	MS	1.0	1024.0	144.0	
	LTL	1.0	176.0	60.0	
	MP	1.0	559.0	112.0	
	MP	1.0	144.0	48.0	1903.0
GLA1	MA	1.0	1218.0	148.0	1218.0
GLA2	ATTF	1.0	396.0	90.0	396.0
GB	GB	1.0	1296.0	144.0	1296.0
OTH	PH	1.0	30.0	22.0	30.0
P/P	PC	1.0	168.0	52.0	
	PC	1.0	144.0	48.0	312.0
	Net LIVABLE	cnt	1 (rounded)		2,910
	Net BUILDING	cnt	0 (rounded)		1,903

COMMENT TABLE 1

Apex 5/03/2010 Jane
 UPDATED BY CLOBERG 02/12/25
 UPDATED BY CLOBERG 03/31/26

COMMENT TABLE 2

MDL 01/07/25
 JJS 02/25/26

COMMENT TABLE 3

TAGS L3
 TAGS L3

SKETCH/AREA TABLE ADDENDUM

SUBJECT INFO

File No.: 534020 Parcel No.: 091W05D 01100
 Property Address: 11241 Shaff Rd SE
 City: Aumsville County: State: OR ZipCode: 97325
 Owner:
 Client: Client Address:
 Appraiser Name: Inspection Date:

SKETCH

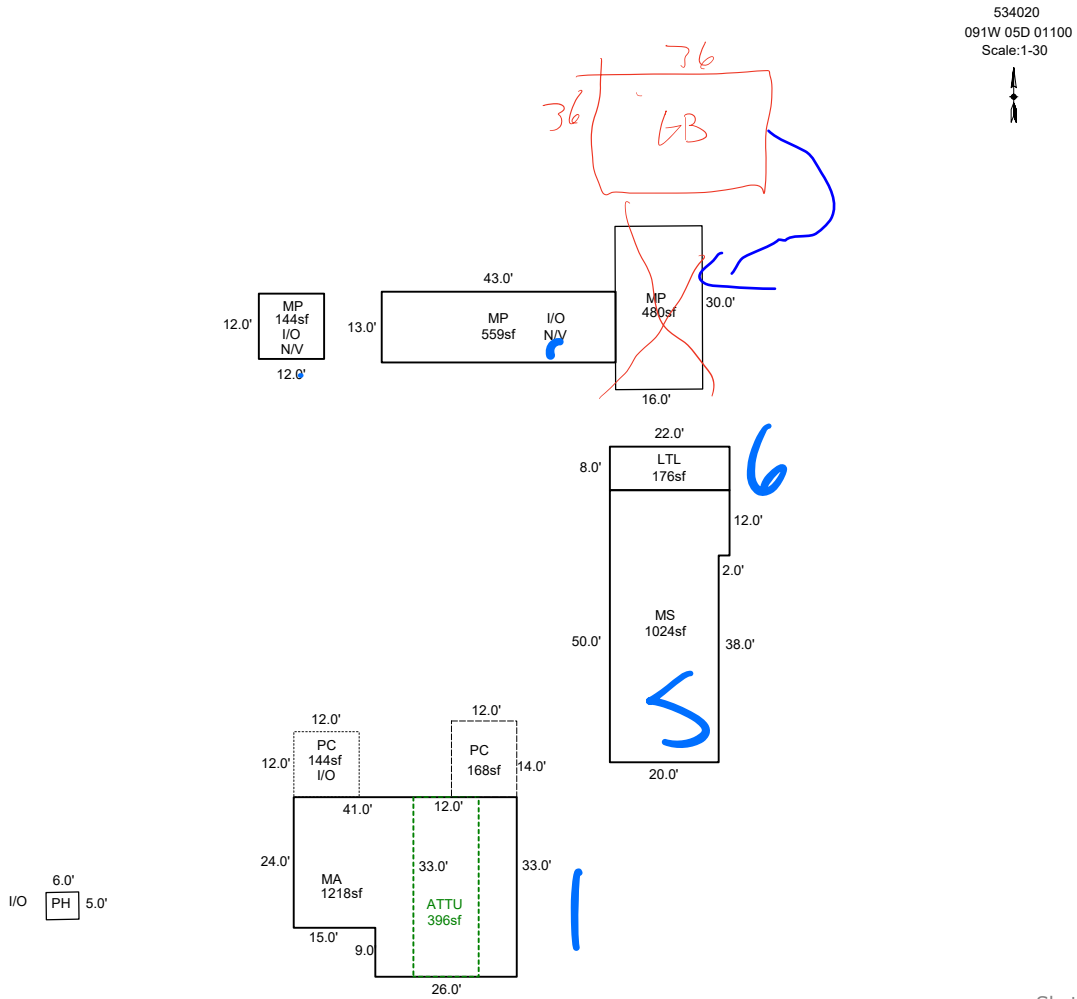

Sketch by ApexSketch

AREA CALCULATIONS SUMMARY

COMMENT TABLE 1

Code	Description	Factor	Net Size	Perimeter	Net Totals
GBA1	MS	1.0	1024.0	144.0	
	LTL	1.0	176.0	60.0	
	MP	1.0	559.0	112.0	
	MP	1.0	144.0	48.0	1903.0
GLA1	MA	1.0	1218.0	148.0	1218.0
GLA2	ATTF	1.0	396.0	90.0	396.0
OTH	PH	1.0	30.0	22.0	
	MP	1.0	480.0	92.0	510.0
P/P	PC	1.0	168.0	52.0	
	PC	1.0	144.0	48.0	312.0

Apex 5/03/2010 Jane
 UPDATED BY CLOBERG 02/12/25

COMMENT TABLE 2

COMMENT TABLE 3

MDL 01/07/25

TAGS L3

JJS
2.2526

TAGS L3

Net LIVABLE	cnt	0	(rounded)		1,614
Net BUILDING	cnt	4	(rounded)		1,903

Assessor Monthly Issued Permit Report

For 10/1/2024 to 10/31/2024

PERMIT#: 555-24-007692-AGE STATUS: Approved
 PERMIT TYPE: Commercial APPLIED: 9/30/2024
 SUB-TYPE: Agricultural Equine APPROVED: 10/31/2024
 CATEGORY: Exemption Info EXPIRES:

OFFICE: MC
 PARCEL#: 091W05D001100 R34020
 ACRES: 2.07
 SUBDIV:
 LOT/BLOCK: /
 ADDRESS: 11241 SHAFF RD SE AUMSVILLE, OR 97325

RELATIONSHIP	NAME	ADDRESS	PHONE
APPLICANT	WILSON, WARREN	11241 SHAFF RD SE AUMSVILLE, OR 97325	503-510-7401
OWNER	WILSON, TRICIA	11241 SHAFF RD SE AUMSVILLE, OR 97325	

CONST CAT:
 WORK TYPE:
 WORK DESC: AGEX 36 x 36 POLE BUILDING, NO PLUMBING
 VALUATION: \$0.00
 STORIES:
 BATHS: KITCHENS:

SQUARE FEET

HABITABLE:
 EXISTING:
 NEW:
TOTAL SQ. FT.: