

# SKETCH/AREA TABLE ADDENDUM

## SUBJECT INFO

File No.: 105690	Parcel No.: 082W29DB01200
Property Address: 5060 DELANEY RD SE	
City: TURNER	County: Marion
State: OR	ZipCode: 97392
Owner:	
Client:	
Appraiser Name:	Client Address:
Inspection Date:	

## SKETCH

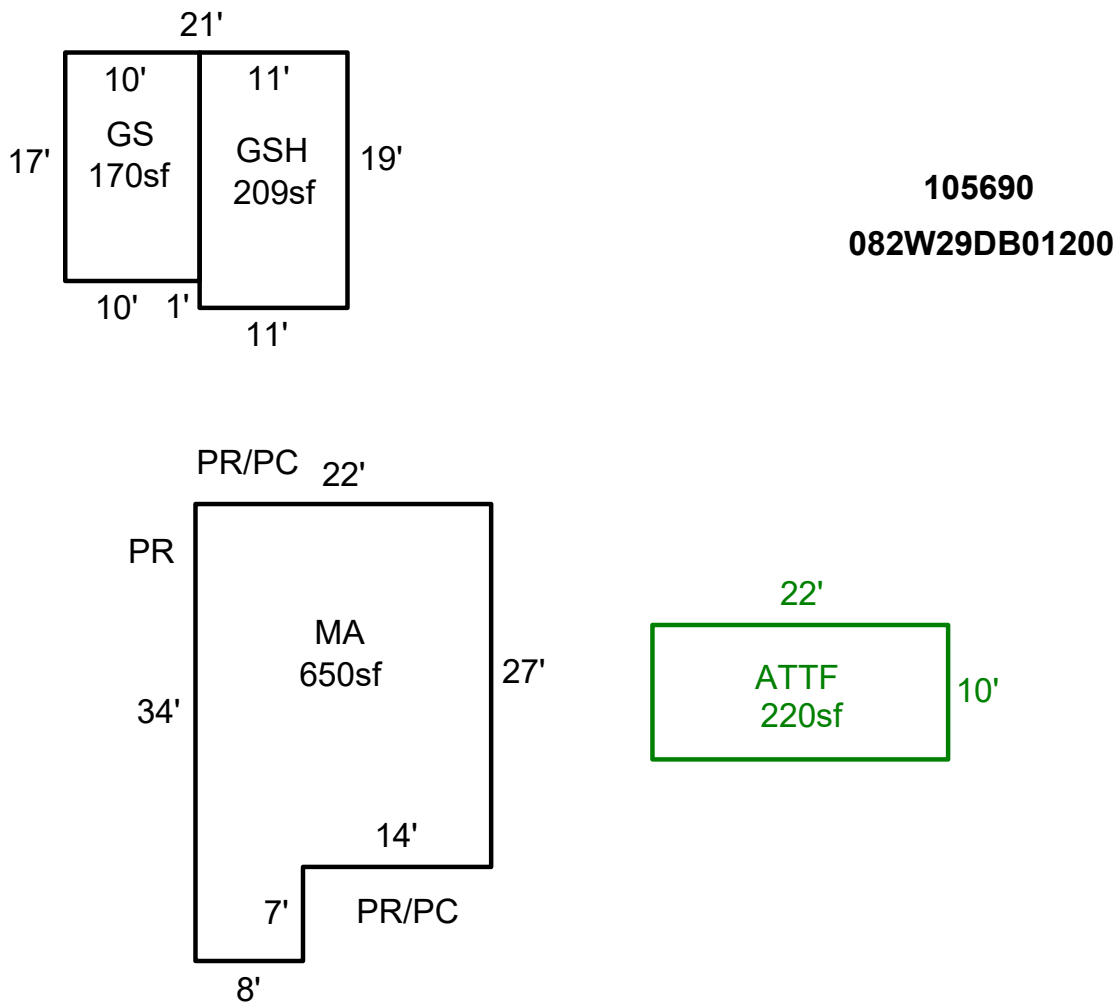

**105690**  
**082W29DB01200**

Sketch by ApexSketch

### AREA CALCULATIONS SUMMARY

Code	Description	Factor	Net Size	Perimeter	Net Totals
GBA	GS	1.0	170.0	54.0	
	GSH	1.0	209.0	60.0	379.0
GLA	MA	1.0	650.0	112.0	650.0
GLA2	ATTF	1.0	220.0	64.0	220.0

### COMMENT TABLE 1

APEX BY MJB 09-10-08  
UPDATED BY LK 3.6.26  
Updated by AE 3.24.26

### COMMENT TABLE 2

10-4-21 #96 Cycle  
2-20-26 GM Cycle

### COMMENT TABLE 3

Net LIVABLE	cnt	2	(rounded)		870
Net BUILDING	cnt	2	(rounded)		379