

Acct ID: 560745 MTL: 093W14D000101 Date: 9/4/25 Appr: MLH Prop Class: 649 RMV Prop Class: 409
 Situs: 2389 STEIWER RD SE JEFFERSON OR 97352 MaSaNh: 07 06 006 Unit: 107848 Year: 2025

Last Date Appraised: 07/10/2009 Appraiser: MATT LORD Retag: Y N Tag info:
 Owner: BIRRUETA JRLT Roll Type: R
 Cycle Tag Sales Verification Other: Clean up Inspection level: 1 2 3 4 LCB TTO INSP AV: 149134
 RMV Land: 352710 RMV Imp: 189900 RMV Total: 542610 MAV: 146780 MSAV: 2354 SAV: 4563
 Comment:

update Inventory Input MLH 9/8/25

Notations

RP/MS	Code	Description
MS	DFL	DESIGNATED FORESTLAND
MS	DFL	DESIGNATED FORESTLAND

OSDs

Count	Code	Description	RMV	Code Area	Exception
1	MKTA	OSD - AVERAGE	50000	14530	0

Land

Site: 1	Code Area: 14530	Size: 1.00 Acres	Use Code: 004	Zone: NREST	SAV Use:	Exception: 0
Class:	Value Source: Market Homesite	Description:			RMV: 49540	Exception: Y N
Adjustment(s):		Fire Patrol:		Description:		
Comments: 16-17: COMB LIKE SEGS // 14-15: 0.65 ACRES DISQ FOREST USE // 81400130//09-10: HOMESITE IS NOT SPEC ASS'D DUE TO ZONING BEING A NON-RESOURCE ZONE//03-04: REAPPRAISAL 04-05: RECALC PROJECT, LAND SCHEDULE CHANGES.						
Site: 2	Code Area: 14530	Size: 4.11 Acres	Use Code: 004	Zone: NREST	SAV Use: 011	Exception: 0
Class: FTL	Value Source: Designated Forest Land	Description: DFL Class C			RMV: 203630	Exception: Y N
Adjustment(s):		Fire Patrol:		Description:		
Comments: Liability year - 1984 / 14-15: 0.65 ACRES DISQ FOREST USE// 81400130 04-05: RECALC PROJECT, LAND SCHEDULE CHANGES.						
Site: 4	Code Area: 14530	Size: 1.00 Acres	Use Code: 004	Zone: NREST	SAV Use:	Exception: 0
Class:	Value Source: Rural at MKT	Description:			RMV: 49540	Exception: Y N
Adjustment(s):		Fire Patrol:		Description:		
Comments:						

Improvements - Residence / Manufactured Structures

Bldg: 1	Code Area: 14530	Stat Class: 464	Year Blt: 1980	Eff Year Blt: 1995	Sq.Ft: 630	% Complete: 100			
Desc: MANUF STRUCT, CLASS 6, 14' WIDE SINGLE			Dimensions: 45x14		RMV: 34930				
Func Obsc: 100	Econ %: 100	Other %: 100	Exception: 0	Adjust:	Adjust RMV: 0				
<i>Area changed to Personal</i>									
Floors									
Type	Class	Display Group	Floor Size	Beds	Baths	Yr Blt	Eff Yr Blt	Inventory	Exception: Y N
First Floor	6	Finished	630	3	FB-1	1980	1995	BATH - 1, KIT-, HVAC+, ROOF+, SKIRT	Exception: Y N

Accessories

Description	Class	Size SqFt	Eff Yr Blt	RMV	Quantity
No accessory data available					

Bldg: 1	Code Area: 14530	Stat Class: 148	Year Blt: 1999	Eff Year Blt: 1999	Sq.Ft: 0	% Complete: 100			
Desc: Res other improvements			Dimensions:		RMV: 128280				
Func Obsc: 100	Econ %: 100	Other %: 100	Exception: 0	Adjust:	Adjust RMV: 0	<i>I/O</i>			
Floors									
Type	Class	Display Group	Floor Size	Beds	Baths	Yr Blt	Eff Yr Blt	Inventory	Exception: Y N
Garage Detached	4	Finished	900	0	0	1999	1999	ROOF	Exception: Y N

Accessories

Description	Class	Size SqFt	Eff Yr Blt	RMV	Quantity	
DECK <i>part of UI</i>	4	450	1999	8712	1	Exception: Y N
YARD IMPROVEMENTS GOOD	4	1	1999	37664	1	Exception: Y N

Improvements - Accessory Buildings

Bldg: 2	Code Area: 14530	Stat Class: 351	Year Blt: 2001	Eff Year Blt: 2001	Sq.Ft: 2240	% Complete: 100
Desc: General Purpose Building (GB)			Dimensions: 40x56		RMV: 24690	
Func Obsc: 100	Econ %: 100	Other %: 100	Exception: 0	Adjust:	Adjust RMV: 0	
Floors						

I/O

Type	Class	Display Group	Floor Size	Beds	Baths	Yr Blt	Eff Yr Blt	Inventory	Exception: Y N
General Purpose Bldg	5	Finished	2240	0	0	2001	2001	FAIR <i>ADe</i>	

Accessories

Description	Class	Size SqFt	Eff Yr Blt	RMV	Quantity
No accessory data available					

Bldg: 3 Code Area: 14530 Stat Class: 301 Year Blt: 2000 Eff Year Blt: 2000 Sq.Ft: 0 % Complete: 100
 Desc: Accessory Improvements & Misc. Dimensions: RMV: 2000
 Func Obsc: 100 Econ %: 100 Other %: 100 Exception: 0 Adjust: Adjust RMV: 0

Floors Gate part of 4± move MAU

Type	Class	Display Group	Floor Size	Beds	Baths	Yr Blt	Eff Yr Blt	Inventory	Exception: Y N
Building Structure	0	Finished	0	0	0	2000	2000		

Accessories

Description	Class	Size SqFt	Eff Yr Blt	RMV	Quantity
No accessory data available					

341 MP 4 16x16 Fair 1984 I/O

355 LTH 56x30 2016 NEW

SKETCH/AREA TABLE ADDENDUM

SUBJECT INFO

File No.: 560745 Parcel No.: 093W14D 00101
 Property Address: 2389 Steiwer Rd SE
 City: Jefferson County: State: OR ZipCode: 97352
 Owner:
 Client: Client Address:
 Appraiser Name: Inspection Date:

SKETCH

560745
093W14D 00101

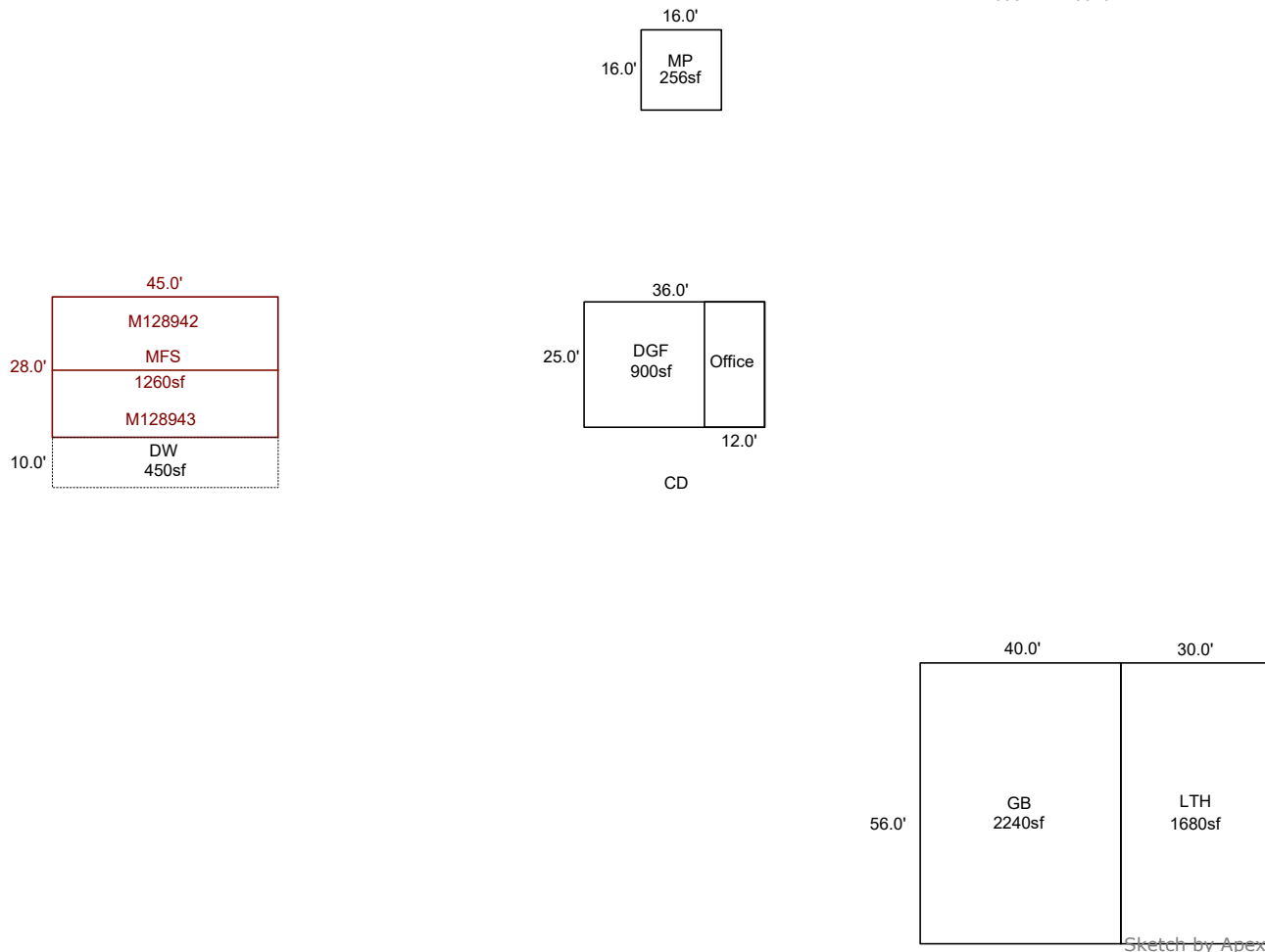

Sketch by ApexSketch

AREA CALCULATIONS SUMMARY

Code	Description	Factor	Net Size	Perimeter	Net Totals
GBA1	MP	1.0	256.0	64.0	
	LTH	1.0	1680.0	172.0	1936.0
GLA1	MFS	1.0	1260.0	146.0	1260.0
GAR	DGF	1.0	900.0	122.0	900.0
OTH	Office	1.0	300.0	74.0	
	GB	1.0	2240.0	192.0	2540.0
P/P	DW	1.0	450.0	110.0	450.0
	Net LIVABLE	cnt	0 (rounded)		1,260
	Net BUILDING	cnt	2 (rounded)		1,936

COMMENT TABLE 1

APEX 1/22/2010 Jane
 UPDATED BY CLOBERG 10/17/25

COMMENT TABLE 2

MLH 09/04/25

COMMENT TABLE 3

CLEAN UP L4

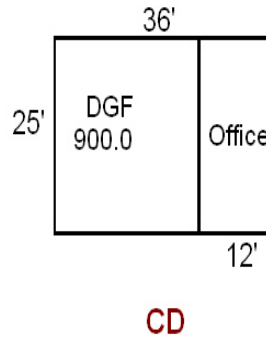
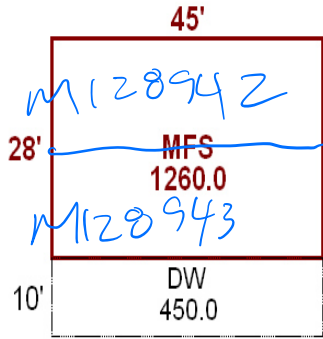
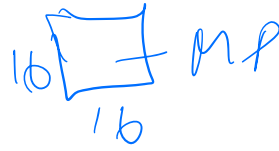

R60745
093W14D 00101

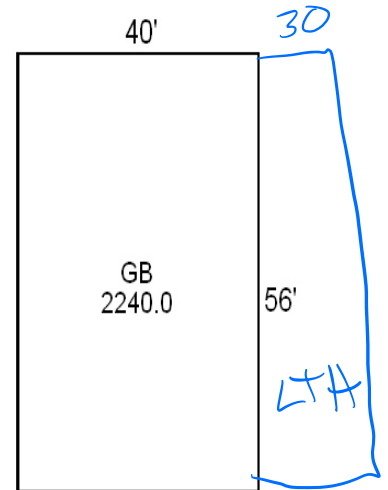

9/4/25 MLH
Clean up Lx