

Acct ID: 547419 MTL: 052W32B000500 Date: 9/2/25 Appr: MLH Prop Class: 551 RMV Prop Class: 451
 Situs: 4641 RUNCORN RD NE GERVAIS OR 97026 MaSaNh: 02 06 000 Unit: 107879 Year: 2025

Last Date Appraised: 12/31/2014 Appraiser: JORDAN SCHULTZ Retag: Y N Tag info:
 Owner: CHAVEZ, ISRAEL Roll Type: R
 Cycle Tag Sales Verification Other: Clean up Inspection level: 1 2 3 4 LCB TTO INSP AV: 159939
 RMV Land: 437810 RMV Imp: 152170 RMV Total: 589980 MAV: 117350 MSAV: 42589 SAV: 101177
 Comment:

Notations

update Inventory

Input MLH 9/2/25

RP/MS	Code	Description
RP	ZONED	FARM EFU ZONED

OSDs

Count	Code	Description	RMV	Code Area	Exception
1	SAA	SA OSD - AVERAGE	50000	01600	0

Land

Site: 2	Code Area: 01600	Size: 1.00 Acres	Use Code: 005	Zone: REST	SAV Use: 011	Exception: 0
Class: <u>2</u>	Value Source: Farm Homesite	Description:			RMV: 69250	Exception: Y N
Adjustment(s): GSOIL, IRR		Fire Patrol:		Description:		
Comments: Liability year - 2009 / 100030						
Site: 3	Code Area: 01600	Size: 4.00 Acres	Use Code: 005	Zone: REST	SAV Use: 011	Exception: 0
Class: 2BI	Value Source: Farm Use - EFU	Description: TWO BENCH IRR			RMV: 318560	Exception: Y N
Adjustment(s): GSOIL, IRR		Fire Patrol:		Description:		
Comments: Liability year - 1976 / 100030						

Improvements - Residence / Manufactured Structures

Bldg: 1	Code Area: 01600	Stat Class: 121	Year Blt: 1950	Eff Year Blt: 1950	Sq.Ft: 1642	% Complete: 100
Desc: One Story Only			Dimensions:		RMV: 103390	
Func Obsc: 100	Econ %: 100	Other %: 100	Exception: 0	Adjust:	Adjust RMV: 0	<i>I/O</i>

Floors

Type	Class	Display Group	Floor Size	Beds	Baths	Yr Blt	Eff Yr Blt	Inventory	Exception
First Floor	2	Finished	1642	2	FB-1	1950	1950	ROOF, HVAC, KIT-, BATH - 1	Y N

Accessories

Description	Class	Size SqFt	Eff Yr Blt	RMV	Quantity
No accessory data available					
<i>EP</i>	<i>2</i>	<i>336</i>			
<i>4I</i>	<i>2A</i>				

Improvements - Accessory Buildings

Bldg: 2	Code Area: 01600	Stat Class: 341	Year Blt: 1983	Eff Year Blt: 1983	Sq.Ft: 216	% Complete: 100
Desc: Multi Purpose Shed (MP)			Dimensions: 18x12		RMV: 1130	
Func Obsc: 100	Econ %: 100	Other %: 100	Exception: 0	Adjust:	Adjust RMV: 0	<i>n/c</i>

Floors

Type	Class	Display Group	Floor Size	Beds	Baths	Yr Blt	Eff Yr Blt	Inventory	Exception
Multi-Purpose Bldg	5	Finished	216	0	0	1983	1983	FAIR	Y N

Accessories

Description	Class	Size SqFt	Eff Yr Blt	RMV	Quantity
No accessory data available					

Bldg: 3	Code Area: 01600	Stat Class: 351	Year Blt: 1983	Eff Year Blt: 1983	Sq.Ft: 800	% Complete: 100
Desc: General Purpose Building (GB)			Dimensions: 40x20		RMV: 3680	
Func Obsc: 100	Econ %: 100	Other %: 100	Exception: 0	Adjust:	Adjust RMV: 0	<i>n/c</i>

Floors

Type	Class	Display Group	Floor Size	Beds	Baths	Yr Blt	Eff Yr Blt	Inventory	Exception
General Purpose Bldg	5	Finished	800	0	0	1983	1983	FAIR	Y N

Accessories

Description	Class	Size SqFt	Eff Yr Blt	RMV	Quantity
No accessory data available					

Bldg: 4	Code Area: 01600	Stat Class: 353	Year Blt: 1983	Eff Year Blt: 1983	Sq.Ft: 2240	% Complete: 100
---------	------------------	-----------------	----------------	--------------------	-------------	-----------------

Desc: Machine Shed (MS)

Dimensions: 70x22 RMV: 3780

I/O

Func Obsc: 100

Econ %: 100

Other %: 100

Exception: 0

Adjust:

Adjust RMV: 0

Floors

Type	Class	Display Group	Floor Size	Beds	Baths	Yr Blt	Eff Yr Blt	Inventory	Exception: Y N
Machine Shed	4	Finished	2240	0	0	1983	1983	Fair	

Accessories

Description	Class	Size SqFt	Eff Yr Blt	RMV	Quantity
No accessory data available					

Bldg: 5 Code Area: 01600 Stat Class: 301 Year Blt: Eff Year Blt: Sq.Ft: 336 % Complete: 100

Desc: Accessory Improvements & Misc.

EP move to MA

Dimensions: 21x16

RMV: 1000

Func Obsc: 100

Econ %: 100

Other %: 100

Exception: 0

Adjust:

Adjust RMV: 0

Floors

Type	Class	Display Group	Floor Size	Beds	Baths	Yr Blt	Eff Yr Blt	Inventory	Exception: Y N
Building Structure	0	Finished	336	0	0	0	0	Move MAU	

Accessories

Description	Class	Size SqFt	Eff Yr Blt	RMV	Quantity
No accessory data available					

Bldg: 6 Code Area: 01600 Stat Class: 351 Year Blt: 2014 Eff Year Blt: 2014 Sq.Ft: 2400 % Complete: 100

Desc: General Purpose Building (GB)

Dimensions: 40x60

RMV: 39190

Func Obsc: 100

Econ %: 100

Other %: 100

Exception: 0

Adjust:

Adjust RMV: 0

I/O

Floors

Type	Class	Display Group	Floor Size	Beds	Baths	Yr Blt	Eff Yr Blt	Inventory	Exception: Y N
General Purpose Bldg	5	Finished	2400	0	0	2014	2014	Ave	

Accessories

Description	Class	Size SqFt	Eff Yr Blt	RMV	Quantity
No accessory data available					

351 GB 5 1999 20x44 Fair I/O
 355 LTH 1983 20x24 I/O
 355 LTH 1999 936 I/O
 905 SO 16,500 Exempt

SKETCH/AREA TABLE ADDENDUM

SUBJECT INFO

File No.: 547419 Parcel No.: 052W32B 00500
 Property Address: 4641 RUNCORN RD NE
 City: GERVAIS County: MARION State: OR ZipCode: 97026
 Owner:
 Client:
 Client Address:
 Appraiser Name: Inspection Date:

SKETCH

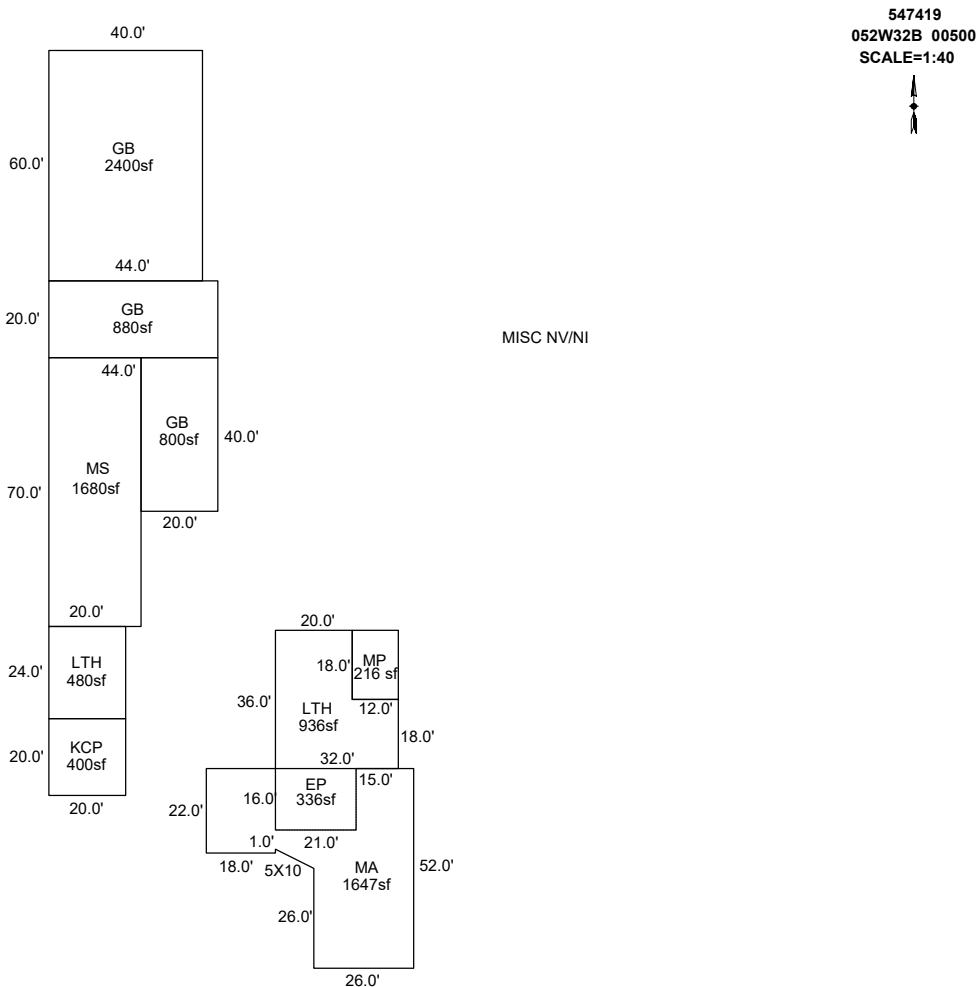

Sketch by ApexSketch

AREA CALCULATIONS SUMMARY						COMMENT TABLE 1	
Code	Description	Factor	Net Size	Perimeter	Net Totals		
GBA1	MP	1.0	216.0	60.0		DRAWN BY JRONDEMA 5/29/15 UPDATED BY CLOBERG 10/27/25	
	MS	1.0	1680.0	188.0			
	GB	1.0	880.0	128.0			
	LTH	1.0	480.0	88.0			
	LTH	1.0	936.0	136.0	4192.0		
GBA2	GB	1.0	800.0	120.0			
	GB	1.0	2400.0	200.0	3200.0		
GLA1	MA	1.0	1647.0	242.2	1647.0		
GAR	KCP	1.0	400.0	80.0	400.0		
P/P	EP	1.0	336.0	74.0	336.0	COMMENT TABLE 2	COMMENT TABLE 3
						MLH 09/02/25	CLEAN UP L4
	Net LIVABLE	cnt	0	(rounded)	1,647		
	Net BUILDING	cnt	7	(rounded)	7,392		

SKETCH/AREA TABLE ADDENDUM

Parcel No 052W32B 00500

File No R47419

Property Address 4641 RUNCORN RD NE

City GERVAIS

County MARION

State OR

Zip 97026

Owner

Client

Appraiser Name

HC
NU/NI

SUBJECT

IMPROVEMENTS SKETCH

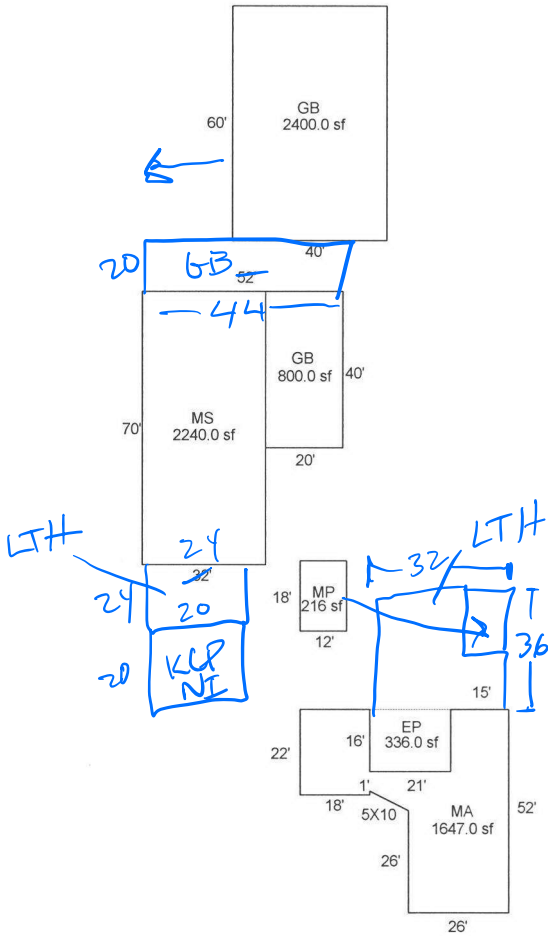

R47419
052W32B 00500
SCALE=1:40



Scale: 1" = 30'

AREA CALCULATIONS

AREA CALCULATIONS SUMMARY

Code	Description	Factor	Net Size	Perimeter	Net Totals
GLA1	MA	1.00	1647.00	242.2	1647.00
GBA1	MP	1.00	216.00	60.0	
	MS	1.00	2240.00	204.0	2456.00
GBA2	GB	1.00	800.00	120.0	
	GB	1.00	2400.00	200.0	3200.00
P/P	EP	1.00	336.00	74.0	336.00

Net LIVABLE Area (rounded w/ factors) 1647
 Net BUILDING Area (rounded w/ factors) 5656

Comment Table 1

DRAWN BY JRONDEMA 5/29/15

Comment Table 2

9/2/25 MLH

Comment Table 3

Clean up 2/4