

Acct ID: 536280 MTL: 093W10D001000 Date: 9/2/25 Appr: MLH Prop Class: 641 RMV Prop Class: 401
 Situs: 10743 SOUTH VIEW LOOP SE JEFFERSON OR 97352 MaSaNh: 06 06 005 Unit: 92270 Year: 2025

Last Date Appraised: 07/23/2009 Appraiser: GERARDO RAMIREZ HERNANDEZ Retag: Y N Tag info:

Owner: CHADBOURNE, LEO B Roll Type: R
 Cycle Tag Sales Verification Other: Clear up Inspection level: 1 2 3 4 LCB TTO INSP AV: 296713
 RMV Land: 396380 RMV Imp: 402500 RMV Total: 798880 MAV: 294760 MSAV: 1953 SAV: 3786

Comment:

update Inventory

Input MLH 9/2/25

Notations

RP/MS	Code	Description
RP	DFL	DESIGNATED FORESTLAND

OSDs

Count	Code	Description	RMV	Code Area	Exception
1	MKTA	OSD - AVERAGE	50000	14530	0

Land

Site: 1	Code Area: 14530	Size: 1.00 Acres	Use Code: 004	Zone: NREST	SAV Use:	Exception: 0
Class: 6H	Value Source: Market Homesite	Description: SIX HILL			RMV: 102850	Exception: Y N
Adjustment(s): VWGR, FSOIL		Fire Patrol:		Description:		
Comments: 81400130, 00-01: separation of homesite from inc //04-05: LAND ADJUSTMENT FOR RECALCULATION DONE BY #29 ON 5-4-04						
Site: 2	Code Area: 14530	Size: 3.41 Acres	Use Code: 004	Zone: NREST	SAV Use: 011	Exception: 0
Class: FTLC	Value Source: Designated Forest Land	Description: DFL Class C			RMV: 243530	Exception: Y N
Adjustment(s): VWGR, FSOIL		Fire Patrol:		Description:		
Comments: Liability year - 1986 / 81400130 //04-05: LAND ADJUSTMENT FOR RECALCULATION DONE BY #29 ON 5-4-04						

Improvements - Residence / Manufactured Structures

Bldg: 1	Code Area: 14530	Stat Class: 143	Year Blt: 1975	Eff Year Blt: 1975	Sq.Ft: 2640	% Complete: 100
Desc: One Story with basement			Dimensions:		RMV: 394210	
Func Obsc: 100	Econ %: 100	Other %: 100	Exception: 0	Adjust:	Adjust RMV: 0	<i>N/C</i>

Floors

Type	Class	Display Group	Floor Size	Beds	Baths	Yr Blt	Eff Yr Blt	Inventory	Exception
First Floor	4	Finished	1320	2	FB-1	1975	1975	ROOF, FP - 1, HVAC, KIT+, BATH - 1	Y N
Basement	4	Finished	1320	3	FB-1	1975	1975	HVAC, BATH - 1	Y N
Garage Attached	4	Unfinished	574	0	0	1975	1975	ROOF	Y N

Accessories

Description	Class	Size SqFt	Eff Yr Blt	RMV	Quantity	Exception
YARD IMPROVEMENTS GOOD	4	1	1975	32528	1	Y N

Improvements - Accessory Buildings

Bldg: 2	Code Area: 14530	Stat Class: 351	Year Blt: 1970	Eff Year Blt: 1970	Sq.Ft: 975	% Complete: 100
Desc: General Purpose Building (GB)			Dimensions: 39x25		RMV: 4490	
Func Obsc: 100	Econ %: 100	Other %: 100	Exception: 0	Adjust:	Adjust RMV: 0	<i>N/C</i>

Floors

Type	Class	Display Group	Floor Size	Beds	Baths	Yr Blt	Eff Yr Blt	Inventory	Exception
General Purpose Bldg	5	Finished	975	0	0	1970	1970	FAIR	Y N

Accessories

Description	Class	Size SqFt	Eff Yr Blt	RMV	Quantity	Exception
No accessory data available						

Bldg: 3	Code Area: 14530	Stat Class: 341	Year Blt: 1970	Eff Year Blt: 1970	Sq.Ft: 384	% Complete: 100
Desc: Multi Purpose Shed (MP) <i>HC</i>			Dimensions: 24x16		RMV: 1800	
Func Obsc: 100	Econ %: 100	Other %: 100	Exception: 0	Adjust:	Adjust RMV: 0	<i>I/O</i>

Floors

Type	Class	Display Group	Floor Size	Beds	Baths	Yr Blt	Eff Yr Blt	Inventory	Exception
Multi-Purpose Bldg	5	Finished	384	0	0	1970	1970	FAIR	Y N

Accessories

Description	Class	Size SqFt	Eff Yr Blt	RMV	Quantity
No accessory data available					

Bldg: 4 Code Area: 14530 Stat Class: 301 Year Blt: Eff Year Blt: Sq.Ft: 0 % Complete: 100

Desc: Accessory Improvements & Misc.

Dimensions: RMV: 2000

Func Obsc: 100

Econ %: 100

Other %: 100

Exception: 0

Adjust:

Adjust RMV: 0

gate part of V.I more MAJ

Floors

Type	Class	Display Group	Floor Size	Beds	Baths	Yr Blt	Eff Yr Blt	Inventory	Exception: Y N
Building Structure	0	Finished	0	0	0	0	0		Exception: Y N

Accessories

Description	Class	Size SqFt	Eff Yr Blt	RMV	Quantity
No accessory data available					

353	MS	5	2020	232sf	AJE	NEW
353	MS	5	2020	20x16	AJE	NEW
353	MS	5	1984	14x30	Fair	I/O

SKETCH/AREA TABLE ADDENDUM

SUBJECT INFO

File No.: 536280 Parcel No.: 093W10D001000
 Property Address: 10743 SOUTH VIEW LOOP SE
 City: JEFFERSON County: State: OR ZipCode:
 Owner:
 Client: Client Address:
 Appraiser Name: Inspection Date:

SKETCH

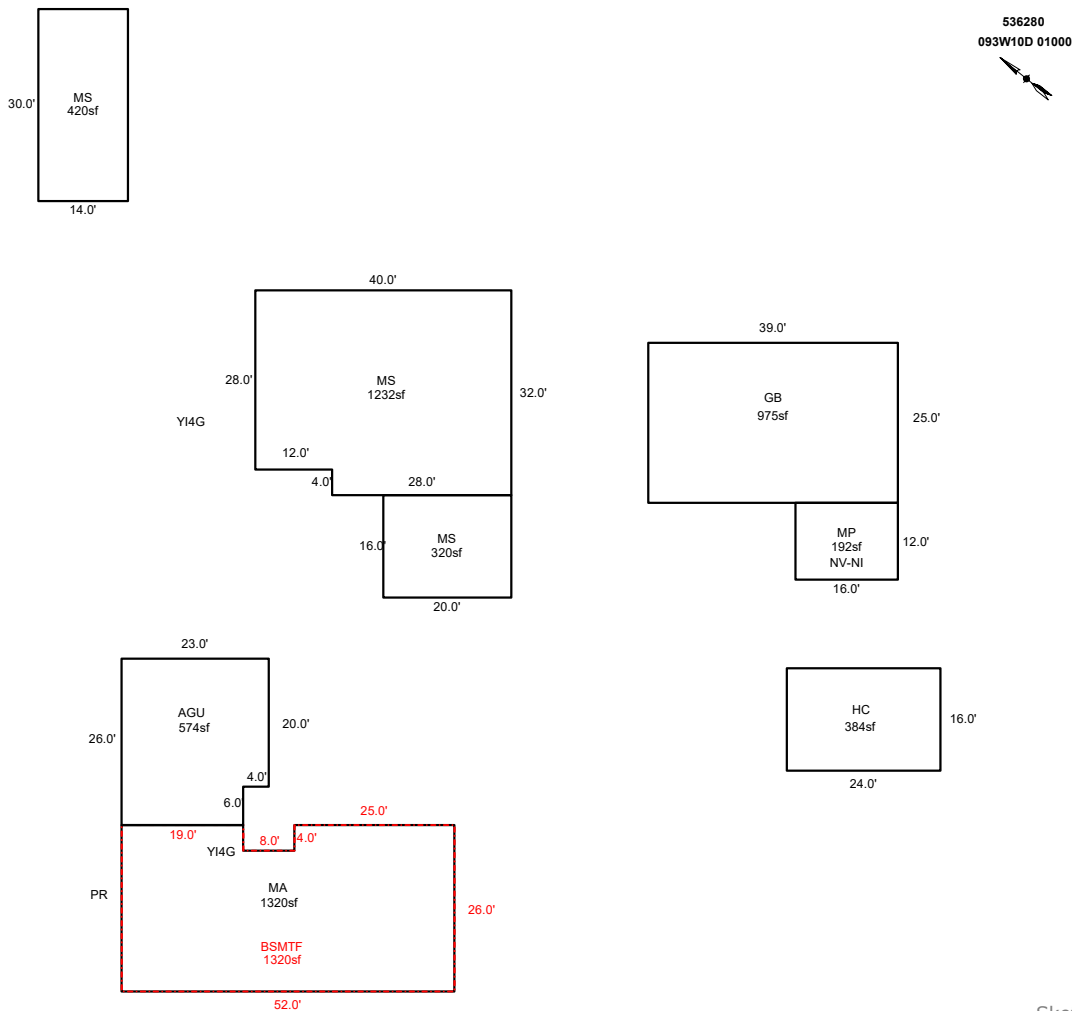

Sketch by ApexSketch

AREA CALCULATIONS SUMMARY						COMMENT TABLE 1	
Code	Description	Factor	Net Size	Perimeter	Net Totals		
GBA1	GB	1.0	975.0	128.0		APEX BY CE 7/29/09 UPDATED BY CLOBERG 10/17/25	
	HC	1.0	384.0	80.0			
	MP	1.0	192.0	56.0			
	MS	1.0	1232.0	144.0			
	MS	1.0	320.0	72.0			
	MS	1.0	420.0	88.0	3523.0		
GLA0	BSMTF	1.0	1320.0	164.0	1320.0		
GLA1	MA	1.0	1320.0	164.0	1320.0		
GAR	AGU	1.0	574.0	98.0	574.0		
						COMMENT TABLE 2	COMMENT TABLE 3
						MLH 09/02/25	CLEAN UP L4
		Net LIVABLE	cnt	0 (rounded)	2,640		
		Net BUILDING	cnt	6 (rounded)	3,523		

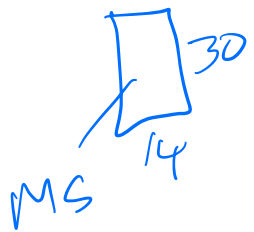

R36280
093W10D 01000

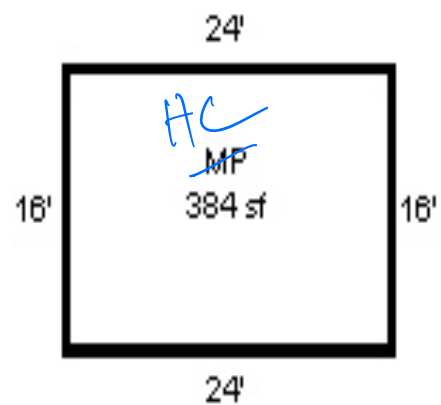
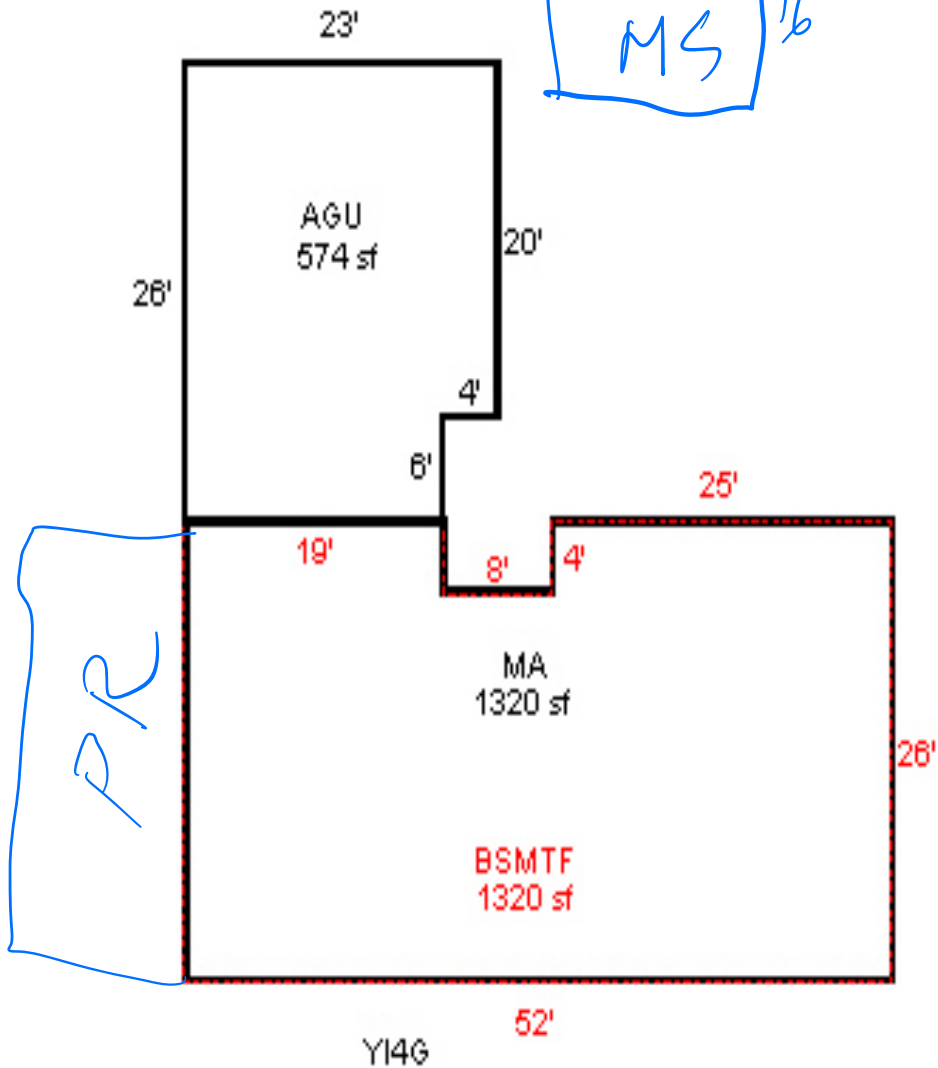
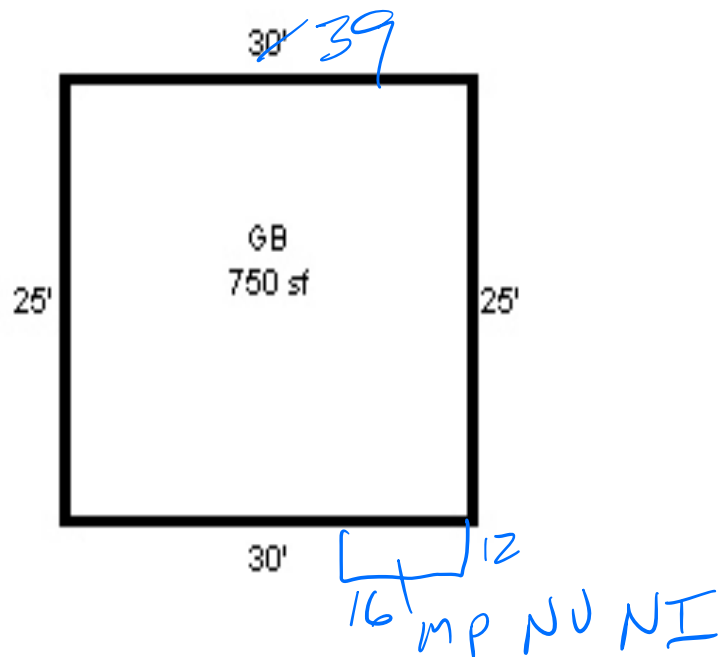
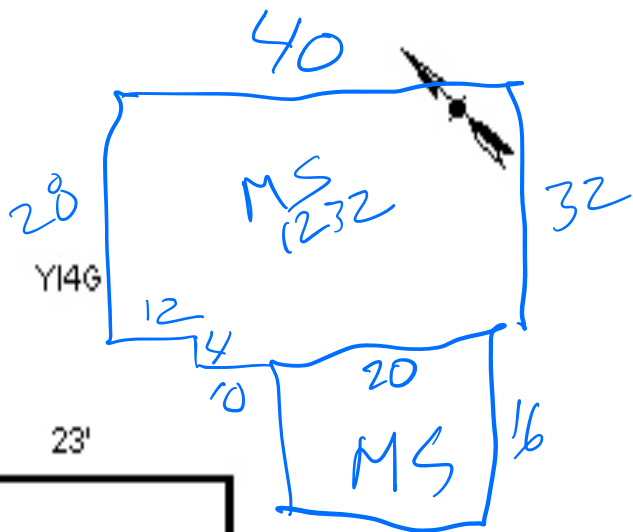

9/2/25 MLH Cleanup L4