

Summary

Lead Appr: MLH Clerk: _____ Lead Clerk: _____ Appr: MLH 4/6/26

Print Date: 9/26/2025

Acct ID: 522763 MTL: 072W03D000700 Date: 1/7/26 Appr: MLH Prop Class: 551 RMV Prop Class: 551
Situs: 7088 INDIGO ST NE SALEM OR 97305 MaSaNh: 03 06 000 Unit: 61289 Year: 2026

Last Date Appraised: 06/01/2012 Appraiser: MATTHEW HAMILTON Tag: Y N Tag info: 2026 - NEW CONSTRUCTION (Addition)

Owner: ROTH BOYS FARMLAND LLC Last Sales Date: _____ Roll Type: R

Cycle: Tag Sales Verification Other: _____ Inspection level: 1 2 3 4 LCB: TTC INSP AV: 479278

RMV Land: 507080 RMV Imp: 366260 RMV Total: 873340 MAV: 287460 MSAV: 192798 SAV: 512979

Comment:

*Garage Addn
MA Addn NEW Bath Input MLH 3/20/26*

Notations

RP/MS	Code	Description
RP	ZONED	FARM EFU ZONED

Farm Seed

OSDs

Count	Code	Description	RMV	Code Area	Exception
1	SAA	SA OSD - AVERAGE	50000	04410	0

Land

Site: 2 Code Area: 04410 Size: 1.00 Acres Use Code: 005 Zone: REST SAV Use: 011 Exception: 0
 Class: 2B1 Value Source: Farm Homesite Description: RMV: 3750 Exception: Y N
 Adjustment(s): GSOIL, IRR **2BD** Fire Patrol: Description:
 Comments: Liability year - 2009 / 400218

Site: 3 Code Area: 04410 Size: 105.26 Acres Use Code: 005 Zone: REST SAV Use: 011 Exception: 0
 Class: 2B1 Value Source: Farm Use - EFU Description: TWO BENCH IRR RMV: 453330 Exception: Y N
 Adjustment(s): GSOIL, IRR Fire Patrol: Description: *M/M*
 Comments: Liability year - 1974 / 400218 *1974 I/O → 1988 → 1993*

Improvements - Residence / Manufactured Structures

Bldg: 1 Code Area: 04410 Stat Class: 141 Year Blt: 1963 Eff Year Blt: 1970 Sq.Ft: 1837 % Complete: 100.00
 Desc: One Story Only Dimensions: RMV: 298920
 Func Obsc: 100 Econ %: 100 Other %: 100 Exception: 0 Adjust: Adjust RMV: 0 *M/M*

Floors

Type	Class	Display Group	Floor Size	Beds	Baths	Yr Blt	Eff Yr Blt	Inventory	Exception
First Floor <i>Addn</i>	4	Finished	1837	3	<u>3</u> FB-2	1963	1970	FP - 2, HVAC, ROOF, BATH - 2, KIT+	Exception: Y N
Garage Attached <i>Addn</i>	4	<u>Flow Cost</u>	578	0	0	1963	1970	ROOF <i>1 Bath M/M</i>	Exception: Y N

Accessories

Description	Class	Size SqFt	Eff Yr Blt	RMV	Quantity	Exception
YARD IMPROVEMENTS AVERAGE	4	1	1970	23433	1	Exception: Y N

Improvements - Accessory Buildings

Bldg: 2 Code Area: 04410 Stat Class: 351 Year Blt: 1989 Eff Year Blt: 1989 Sq.Ft: 2160 % Complete: 100.00
 Desc: General Purpose Building (GB) Dimensions: 60x36 RMV: 14980
 Func Obsc: 100 Econ %: 100 Other %: 100 Exception: 0 Adjust: Adjust RMV: 0 *N/C*

Floors

Type	Class	Display Group	Floor Size	Beds	Baths	Yr Blt	Eff Yr Blt	Inventory	Exception
General Purpose Bldg	5	Finished	2160	0	0	1989	1989	AVG	Exception: Y N

Accessories

Description	Class	Size SqFt	Eff Yr Blt	RMV	Quantity
No accessory data available					

Bldg: 3 Code Area: 04410 Stat Class: 353 Year Blt: 1989 Eff Year Blt: 1989 Sq.Ft: 837 % Complete: 100.00
 Desc: Machine Shed (MS) Dimensions: 40x18 RMV: 4170
 Func Obsc: 100 Econ %: 100 Other %: 100 Exception: 0 Adjust: Adjust RMV: 0 *N/C*

Floors

Type	Class	Display Group	Floor Size	Beds	Baths	Yr Blt	Eff Yr Blt	Inventory	Exception
Machine Shed	5	Finished	837	0	0	1989	1989	FAIR	Exception: Y N

Accessories

Description	Class	Size SqFt	Eff Yr Blt	RMV	Quantity
No accessory data available					

Bldg: 4 Code Area: 04410 Stat Class: 341 Year Blt: _____ Eff Year Blt: _____ Sq.Ft: 64 % Complete: 100.00

Desc: Multi Purpose Shed (MP) Dimensions: 8x8 RMV: 260

Func Obsc: 100 Econ %: 100 Other %: 100 Exception: 0 Adjust: Adjust RMV: 0

Floors

Type	Class	Display Group	Floor Size	Beds	Baths	Yr Blt	Eff Yr Blt	Inventory	Exception: Y N
Multi-Purpose Bldg	4	Finished	64	0	0	0	0	FAIR	

Accessories

Description	Class	Size SqFt	Eff Yr Blt	RMV	Quantity
No accessory data available					

Bldg: 5 Code Area: 04410 Stat Class: 341 Year Blt: 1985 Eff Year Blt: 1985 Sq.Ft: 320 % Complete: 100.00

Desc: Multi Purpose Shed (MP) Dimensions: 16x20 RMV: 1700

Func Obsc: 100 Econ %: 100 Other %: 100 Exception: 0 Adjust: Adjust RMV: 0

Floors

Type	Class	Display Group	Floor Size	Beds	Baths	Yr Blt	Eff Yr Blt	Inventory	Exception: Y N
Multi-Purpose Bldg	5	Finished	320	0	0	1985	1985	FAIR	

Accessories

Description	Class	Size SqFt	Eff Yr Blt	RMV	Quantity
No accessory data available					

Bldg: 6 Code Area: 04410 Stat Class: 325 Year Blt: Eff Year Blt: Sq.Ft: 0 % Complete: 100.00

Desc: Commercial Grain Storage (GR) Dimensions: RMV: 0

Func Obsc: 100 Econ %: 100 Other %: 100 Exception: 0 Adjust: Adjust RMV: 0

Floors

Type	Class	Display Group	Floor Size	Beds	Baths	Yr Blt	Eff Yr Blt	Inventory	Exception: Y N
Grain Bin	4	Finished	0	0	0	0	0		

Accessories

Description	Class	Size SqFt	Eff Yr Blt	RMV	Quantity
No accessory data available					

Bldg: 7 Code Area: 04410 Stat Class: 325 Year Blt: Eff Year Blt: Sq.Ft: 0 % Complete: 100.00

Desc: Commercial Grain Storage (GR) Dimensions: RMV: 0

Func Obsc: 100 Econ %: 100 Other %: 100 Exception: 0 Adjust: Adjust RMV: 0

Floors

Type	Class	Display Group	Floor Size	Beds	Baths	Yr Blt	Eff Yr Blt	Inventory	Exception: Y N
Grain Bin	4	Finished	0	0	0	0	0		

Accessories

Description	Class	Size SqFt	Eff Yr Blt	RMV	Quantity
No accessory data available					

Bldg: 8 Code Area: 04410 Stat Class: 352 Year Blt: 1994 Eff Year Blt: 1994 Sq.Ft: 3840 % Complete: 100.00

Desc: Utility Building (UB) Dimensions: 96x40 RMV: 28330

Func Obsc: 100 Econ %: 100 Other %: 100 Exception: 0 Adjust: Adjust RMV: 0

Floors

Type	Class	Display Group	Floor Size	Beds	Baths	Yr Blt	Eff Yr Blt	Inventory	Exception: Y N
Utility Building	5	Finished	3840	0	0	1994	1994	FAIR	

Accessories

Description	Class	Size SqFt	Eff Yr Blt	RMV	Quantity
No accessory data available					

Bldg: 9 Code Area: 04410 Stat Class: 353 Year Blt: 1994 Eff Year Blt: 1994 Sq.Ft: 3200 % Complete: 100.00

Desc: Machine Shed (MS) Dimensions: RMV: 17630

Func Obsc: 100 Econ %: 100 Other %: 100 Exception: 0 Adjust: Adjust RMV: 0

Floors

Type	Class	Display Group	Floor Size	Beds	Baths	Yr Blt	Eff Yr Blt	Inventory	Exception: Y N
Machine Shed	5	Finished	3200	0	0	1994	1994	FAIR	

Accessories

Description	Class	Size SqFt	Eff Yr Blt	RMV	Quantity
No accessory data available					

Bldg: 10 Code Area: 04410 Stat Class: 353 Year Blt: 1968 Eff Year Blt: 1968 Sq.Ft: 117 % Complete: 100.00

Desc: Machine Shed (MS) Dimensions: RMV: 270

Func Obsc: 100 Econ %: 100 Other %: 100 Exception: 0 Adjust: Adjust RMV: 0

Floors

Type	Class	Display Group	Floor Size	Beds	Baths	Yr Blt	Eff Yr Blt	Inventory
Machine Shed	4	Finished	117	0	0	1968	1968	Exception: Y N

Accessories

Description	Class	Size SqFt	Eff Yr Blt	RMV	Quantity
No accessory data available					

Permits

Permit Number	Permit ID	Origin	Category	Type	Estimate Value	% Complete	Roll Type	Description
25-000605	83479	MARION COUNTY	NEW CONSTRUCTION	ADDITION	299999	0	R	Remodel to Add Shop, Bathroom and Covered Porch to Home



Account Number: 522763 Appraiser: MLH Date: 3/20/2026

Sq. Ft.	% Good	% of Whole	
Addition: 260	100%	12%	12%
Basement:			
First Floor: 1837	82%	88%	72%
Second Floor:			
Attic:			
Total Sq.Ft.: 2097		100%	84% * Updated % Good

1993

SKETCH/AREA TABLE ADDENDUM

SUBJECT INFO

File No.: 522763 Parcel No.: 072W03D 00700
 Property Address: 7088 INDIGO ST NE
 City: SALEM County: MARION State: OR ZipCode: 97305
 Owner:
 Client: Client Address:
 Appraiser Name: Inspection Date:

SKETCH

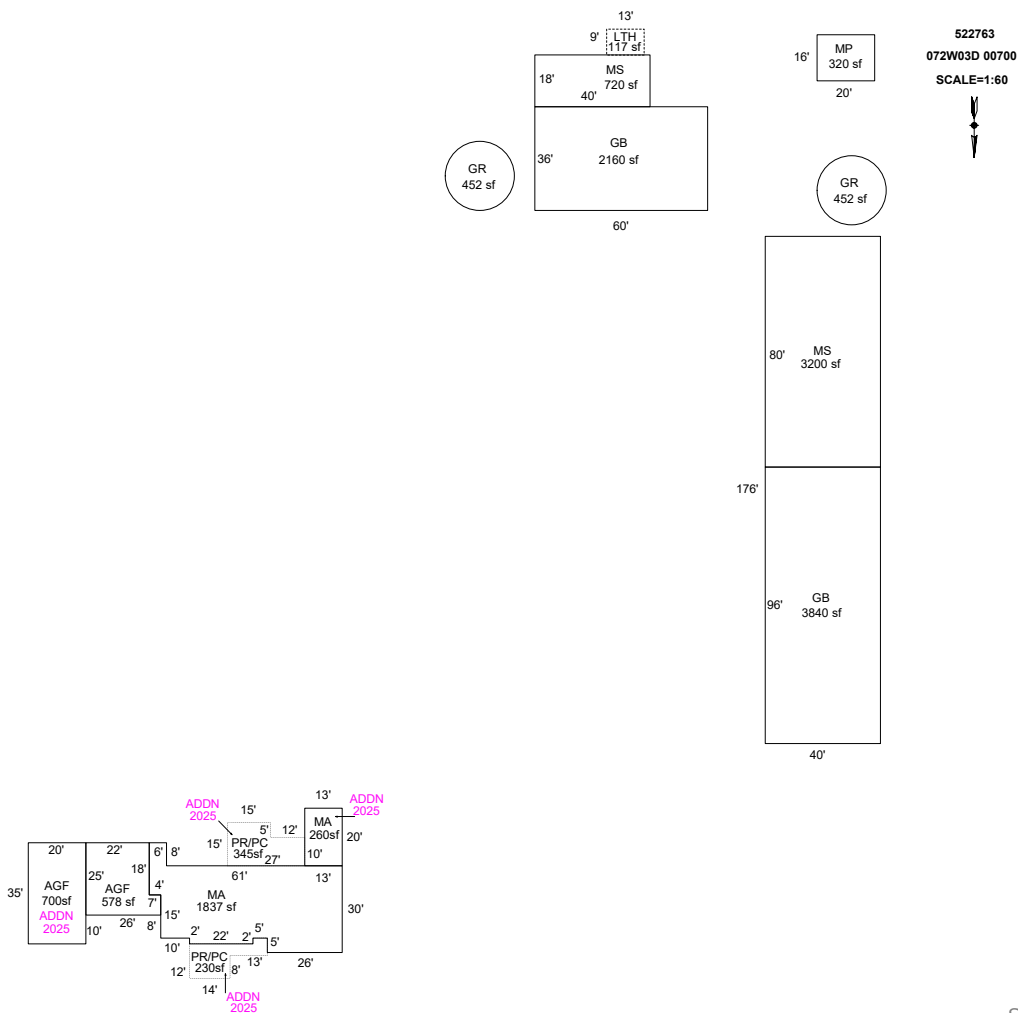

Sketch by ApexSketch

AREA CALCULATIONS SUMMARY

Code	Description	Factor	Net Size	Perimeter	Net Totals
GBA1	GB	1.0	2160.0	192.0	
	MS	1.0	720.0	116.0	
	LTH	1.0	117.0	44.0	
	MP	1.0	320.0	72.0	
	GB	1.0	3840.0	272.0	
	MS	1.0	3200.0	240.0	
	GR	1.0	452.4	75.4	11261.8
GLA1	MA	1.0	1837.0	214.0	1837.0
GAR	AGF	1.0	578.0	102.0	
	AGF	1.0	700.0	110.0	1278.0
MA	MA	1.0	260.0	66.0	260.0
	P/P	1.0	345.0	84.0	
P/P	PR/PC	1.0	230.0	82.0	575.0
	PR/PC	1.0	230.0	82.0	
	Net LIVABLE	cnt	3 (rounded)		3,375
	Net BUILDING	cnt	0 (rounded)		11,262

COMMENT TABLE 1

DRAWN BY JRONDEMA 11/02/17
 UPDATED BY CLOBERG 03/11/25 25-000605 MA ADDN
 UPDATED BY CLOBERG 04/06/26

COMMENT TABLE 2

MLH 01/07/26

COMMENT TABLE 3

TAGS L1

SKETCH/AREA TABLE ADDENDUM

SUBJECT INFO

File No.: 522763 Parcel No.: 072W03D 00700
 Property Address: 7088 INDIGO ST NE
 City: SALEM County: MARION State: OR ZipCode: 97305
 Owner:
 Client: Client Address:
 Appraiser Name: Inspection Date:

SKETCH

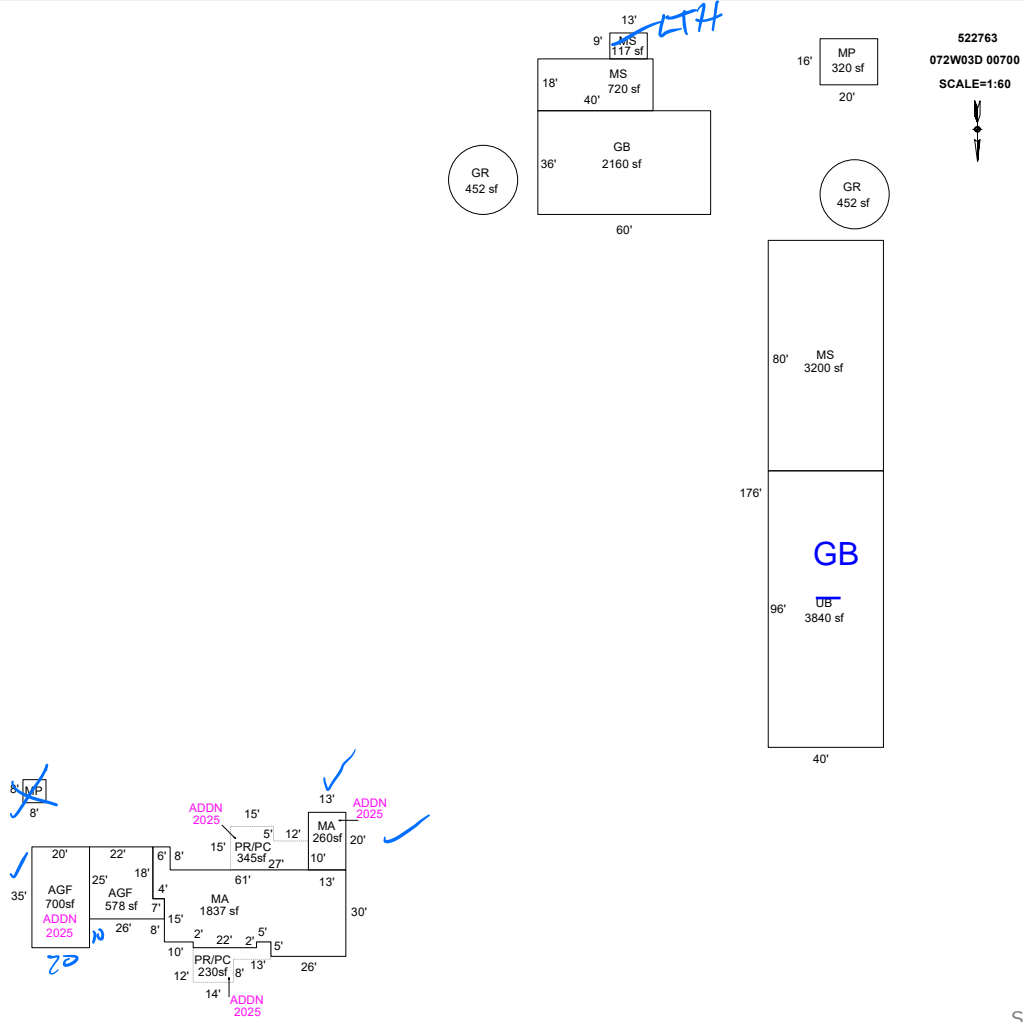

AREA CALCULATIONS SUMMARY

Code	Description	Factor	Net Size	Perimeter	Net Totals
GBA1	GB	1.0	2160.0	192.0	
	MS	1.0	720.0	116.0	
	MS	1.0	117.0	44.0	
	MP	1.0	64.0	32.0	
	MP	1.0	320.0	72.0	
	UB	1.0	3840.0	272.0	
	MS	1.0	3200.0	240.0	
	GR	1.0	452.4	75.4	
	GR	1.0	452.4	75.4	11325.8
GLA1	MA	1.0	1837.0	214.0	1837.0
GAR	AGF	1.0	578.0	102.0	
	AGF	1.0	700.0	110.0	1278.0
MA	MA	1.0	260.0	66.0	260.0
	P/P	1.0	345.0	84.0	
P/P	PR/PC	1.0	230.0	82.0	575.0
	PR/PC	1.0	230.0	82.0	
	Net LIVABLE	cnt	1 (rounded)		2,097
	Net BUILDING	cnt	9 (rounded)		11,326

COMMENT TABLE 1

DRAWN BY JRONDEMA 11/02/17
 UPDATED BY CLOBERG 03/11/25 25-000605 MA ADDN

COMMENT TABLE 2

MLH 1/7/26

COMMENT TABLE 3

Tags < 1



06/01/2012