

Acct ID: 541437 MTL: 093E11BA00201 Date: **2-5-24** Appr: **CLINT** Prop Class: 401 RMV Prop Class: 401
 Situs: 32365 NORTH FORK RD SE LYONS OR 97358 MaSaNh: 01 06 005 Unit: 54504 **INPUT 2-5-24 CLINT** Year: 2024
 Last Date Appraised: 01/26/2023 Appraiser: CLINT LUKE Retag: Y **0** Tag info: _____
 Owner: PREUIT, CECIL A Roll Type: R
0 Tag Sales Verification Other: _____ Inspection level: 1 2 3 4 **0** LCB TTO INSP AV: 296160
 RMV Land: 279960 RMV Imp: 371190 RMV Total: 651150 MAV: 296160 MSAV: 0 SAV: 0
 Comment: 23-24: L2 1-26-23 CL
 LEVEL 4 3.3.21 PHT42//

**JUST UPDATED DURING 23-24 TAGS
NC**

Notations

No notation data available.

OSDs

Count	Code	Description	RMV	Code Area	Exception
1	MKTA	OSD - AVERAGE	45000	56540	0

Land

Site: 1 Code Area: 56540 Size: 1.50 Acres Use Code: 004 Zone: NREST SAV Use: Exception: 0
 Class: 6B Value Source: Rural at MKT Description: SIX BENCH RMV: 234960 Exception: Y N
 Adjustment(s): H2OGR, FSOIL Fire Patrol: Description:
 Comments: 00-01: f99-973 r/w taking, value increase because of previous trending error

Improvements - Residence / Manufactured Structures

Bldg: 1 Code Area: 56540 Stat Class: 142 + Year Blt: 1977 Eff Year Blt: 1987 Sq.Ft: 2204 % Complete: 100
 Desc: Multi Story above grade Dimensions: RMV: 297300
 Func Obsc: 100 Econ %: 100 Other %: 100 Exception: 0 Adjust: Adjust RMV: 0

Floors

Type	Class	Display Group	Floor Size	Beds	Baths	Yr Blt	Eff Yr Blt	Inventory	Exception
First Floor	4 +	Finished	1372	1	FB-1/ HB-1	1977	1987	KIT-, FP - 1, HVAC+, ROOF, BTH - 1, BATH - 1	Y N
Second Floor	4 -	Finished	832	2	FB-1	1977	1987	HVAC, BATH - 1	Y N

Accessories

Description	Class	Size SqFt	Eff Yr Blt	RMV	Quantity	Exception
YARD IMPROVEMENTS GOOD	5	1	1987	38745	1	Y N

Improvements - Accessory Buildings

Bldg: 2 Code Area: 56540 Stat Class: 352 Year Blt: 2022 Eff Year Blt: 2022 Sq.Ft: 3456 % Complete: 100
 Desc: Utility Building (UB) Dimensions: RMV: 62460
 Func Obsc: 100 Econ %: 100 Other %: 100 Exception: 0 Adjust: Adjust RMV: 0

Floors

Type	Class	Display Group	Floor Size	Beds	Baths	Yr Blt	Eff Yr Blt	Inventory	Exception
Utility Building	5	Finished	3456	0	0	2022	2022	FAIR	Y N

Accessories

Description	Class	Size SqFt	Eff Yr Blt	RMV	Quantity
No accessory data available					

Bldg: 3 Code Area: 56540 Stat Class: 355 Year Blt: 2022 Eff Year Blt: 2022 Sq.Ft: 1440 % Complete: 100
 Desc: Lean-to Heavy (LTH) Dimensions: 72x20 RMV: 11430
 Func Obsc: 100 Econ %: 100 Other %: 100 Exception: 0 Adjust: Adjust RMV: 0

Floors

Type	Class	Display Group	Floor Size	Beds	Baths	Yr Blt	Eff Yr Blt	Inventory	Exception
Lean-to Heavy Duty	4	Finished	1440	0	0	2022	2022	FAIR	Y N

Accessories

Description	Class	Size SqFt	Eff Yr Blt	RMV	Quantity
No accessory data available					

SKETCH/AREA TABLE ADDENDUM

SUBJECT INFO

File No.: 541437 Parcel No.: 093E11BA00201
 Property Address: 32365 NORTH FORK RD SE
 City: LYONS County: MARION State: OR ZipCode: 97358
 Owner:
 Client: Client Address:
 Appraiser Name: Inspection Date:

SKETCH

541437
093E11BA 0201
SCALE = 1:40

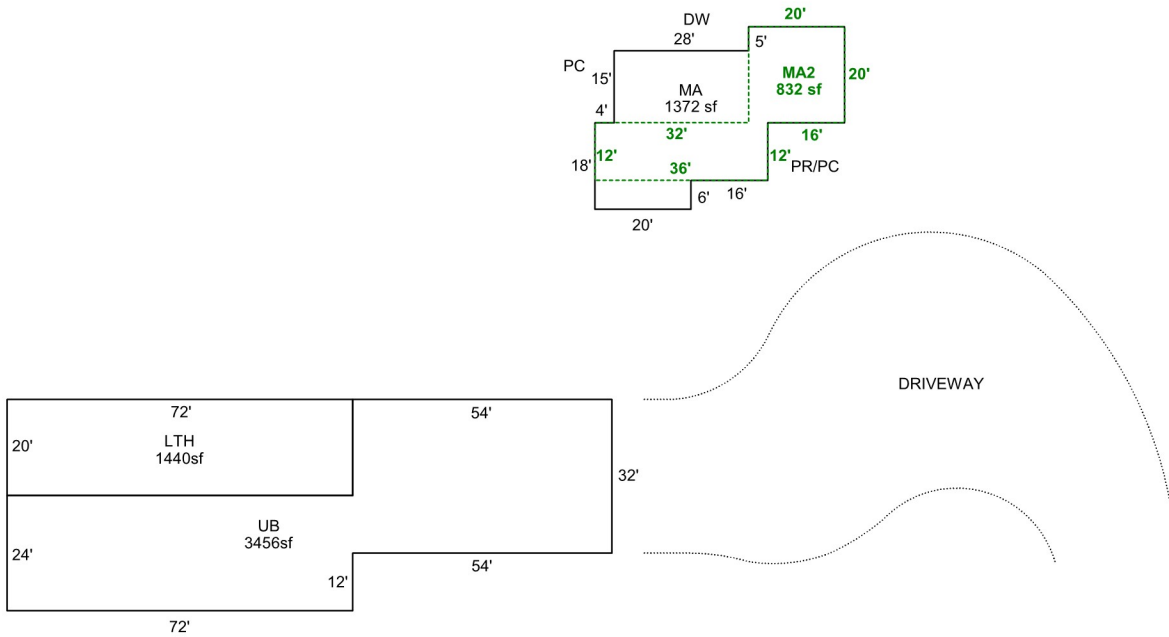

Sketch by Apex Sketch

AREA CALCULATIONS SUMMARY

Code	Description	Factor	Net Size	Perimeter	Net Totals
GBA1	LTH	1.0	1440.0	184.0	
	UB	1.0	3456.0	340.0	4896.0
GLA1	MA	1.0	1372.0	180.0	1372.0
GLA2	MA2	1.0	832.0	168.0	832.0

COMMENT TABLE 1

Apex by JA 3/30/09
 UPDATED BY JRONDEMA 6/24/16
 UPDATED BY CJURAN 06/29/2021
 UPDATED BY CJURAN 02/07/2023

COMMENT TABLE 2

PH T42 03/04/2021 AOG
 #10 CL 01/26/2023

COMMENT TABLE 3

TAGS L2

Net LIVABLE	cnt	2	(rounded)		2,204
Net BUILDING	cnt	2	(rounded)		4,896