

Summary

Lead Appr: WW 11/25 Clerk: \_\_\_\_\_ Lead Clerk: \_\_\_\_\_ Appr: \_\_\_\_\_

Print Date:

9/26/2025

Acct ID: 538928 MTL: 071E26C000400 Date: 11/18/25 Appr: MLH Prop Class: 641 RMV Prop Class: 401457  
Situs: 182 SILVER FALLS DR SE SILVERTON OR 97381 MaSaNh: 03 06 000 Unit: 68867 Year: 2025

2026

Last Date Appraised: 10/29/2024 Appraiser: MATTHEW HAMILTON Tag: Y N Tag info: 2026 - Tags/Permit (Addition)

Owner: PRINCE LT Last Sales Date: 02/18/1988 Roll Type: R

Cycle Tag Sales Verification Other: \_\_\_\_\_ Inspection level: 1 2 3 4 LCB TTO INSP AV: 726042

RMV Land: 486550 RMV Imp: 1121670 RMV Total: 1608220 MAV: 655560 MSAV: 4152 SAV: 8049

Comment: 25-26: L1 10.29.24 MLH

Addn 1 Bed 2 Bath @ 100% AG Ex not started Retag for '27

update inventory close tag input MLH

Notations

RP/MS	Code	Description
RP	DFL	DESIGNATED FORESTLAND

**CWO 11/25/25 Tag to check for replant of harvested area in 2027** 11/20/25  
Forest OK

OSDs

Count	Code	Description	RMV	Code Area	Exception
2	MKTA	OSD - AVERAGE	50000	04480	0

Land

Site: 1 Code Area: 04480 Size: 1.00 Acres Use Code: 005 Zone: REST SAV Use: Exception: 0

Class: 2BDSS Value Source: Market Homesite Description: TWO BENCH DRY SOUTH SPECIAL RMV: 115480 Exception: Y N

Adjustment(s): H2OAR, GSOIL, IRR Fire Patrol: SA004 Description: FIRE PATROL

Comments: 19-20: APPROVED FOR DFL //18-19: DISQ FARM USE// 17-18: UPDATE PART TOTALS / 12-13: PER #31, ADD WATER ADJ FOR POND / 05 -06: RECALC SETUP;#17 5-10-04/ 00-01; UPDATED MARKET VALUE/03- 04: UPDATED PART TOTAL INFO

Site: 3 Code Area: 04480 Size: 1.81 Acres Use Code: 005 Zone: REST SAV Use: Exception: 0

Class: 4BISS Value Source: Rural Restrictive Description: FOUR BENCH IRR SPECIAL SOUTH RMV: 42380 Exception: Y N

Adjustment(s): H2OAR, GSOIL, IRR Fire Patrol: SA004 Description: FIRE PATROL

Comments: 25-26 CORR SOILS

Site: 4 Code Area: 04480 Size: 1.70 Acres Use Code: 005 Zone: REST SAV Use: Exception: 0

Class: 4BDSS Value Source: Rural Restrictive Description: FOUR BENCH DRY SPECIAL SOUTH RMV: 37910 Exception: Y N

Adjustment(s): H2OAR, GSOIL, IRR Fire Patrol: SA004 Description: FIRE PATROL

Comments:

Site: 5 Code Area: 04480 Size: 0.35 Acres Use Code: 005 Zone: REST SAV Use: Exception: 0

Class: 2BDSS Value Source: Rural Restrictive Description: TWO BENCH DRY SOUTH SPECIAL RMV: 8580 Exception: Y N

Adjustment(s): H2OAR, GSOIL, IRR Fire Patrol: SA004 Description: FIRE PATROL

Comments:

Site: 6 Code Area: 04480 Size: 7.25 Acres Use Code: 005 Zone: REST SAV Use: 011 Exception: 0

Class: FTLC Value Source: Designated Forest Land Description: DFL Class C RMV: 161680 Exception: Y N

Adjustment(s): H2OAR, GSOIL, IRR Fire Patrol: SA004 Description: FIRE PATROL

Comments: Liability year - 2019 / 19-20: APPROVED 7.25 ACRES DFL

Site: 7 Code Area: 04480 Size: 2.75 Acres Use Code: 005 Zone: REST SAV Use: Exception: 0

Class: 2BISS Value Source: Rural Restrictive Description: TWO BENCH IRR SOUTH SPECIAL RMV: 70520 Exception: Y N

Adjustment(s): H2OAR, GSOIL, IRR Fire Patrol: SA004 Description: FIRE PATROL

Comments: 25-26 CORR SOILS

Improvements - Residence / Manufactured Structures

2005

Bldg: 1 Code Area: 04480 Stat Class: 154 + Year Blt: 1989 Eff Year Blt: 1998 Sq.Ft: 3537 % Complete: 100.00

Desc: Multi Story above grade with basement Dimensions: RMV: 976640

Func Obsc: 100 Econ %: 100 Other %: 100 Exception: 0 Adjust: Adjust RMV: 0

M/M

Floors

Type	Class	Display Group	Floor Size	Beds	Baths	Yr Blt	Eff Yr Blt	Inventory	Exception
First Floor	5 +	Finished	2267	1	FB-1	1989	1998	HVAC+, ROOF, FP - 1, BATH - 1, KIT	Y N
Second Floor	5 +	Finished	1270	<u>3</u>	FB-1	1989	1998	HVAC+, BATH - 1	Y N
Basement	5 +	Unfinished	1606	0	FB-1	1989	1998	BATH - 1	Y N
Garage Attached	5	Finished	1148	0	0	1989	1998	ROOF	Y N

Addn 955 i 2 Bath 2025

Accessories

Description	Class	Size SqFt	Eff Yr Blt	RMV	Quantity	Exception
YARD IMPROVEMENTS GOOD	5	1	1998	48503	1	Y N

Improvements - Accessory Buildings

Bldg: 2 Code Area: 04480 Stat Class: 353 Year Blt: 1994 Eff Year Blt: 1994 Sq.Ft: 750 % Complete: 100.00

Desc: Machine Shed (MS) Dimensions: RMV: 3410

Func Obsc: 100

Econ %: 100

Other %: 100

Exception: 0

Adjust:

Adjust RMV: 0

N/C

Floors

Type	Class	Display Group	Floor Size	Beds	Baths	Yr Blt	Eff Yr Blt	Inventory	Exception: Y N
Machine Shed	4	Finished	750	0	0	1994	1994	FAIR	

Accessories

Description	Class	Size SqFt	Eff Yr Blt	RMV	Quantity
No accessory data available					

Bldg: 3 Code Area: 04480 Stat Class: 357 Year Blt: Eff Year Blt: 2009 Sq.Ft: 1152 % Complete: 100.00  
 Desc: Frost Control Dimensions: 48x24 RMV: 2600  
 Func Obsc: 100 Econ %: 100 Other %: 100 Exception: 0 Adjust: Adjust RMV: 0

N/C

Floors

Type	Class	Display Group	Floor Size	Beds	Baths	Yr Blt	Eff Yr Blt	Inventory	Exception: Y N
Frost Control	4	Finished	1152	0	0	0	2009		

Accessories

Description	Class	Size SqFt	Eff Yr Blt	RMV	Quantity
No accessory data available					

Bldg: 4 Code Area: 04480 Stat Class: 342 Year Blt: 2024 Eff Year Blt: 2024 Sq.Ft: 3750 % Complete: 100.00  
 Desc: Metal Component Building (MC) Dimensions: 75x50 RMV: 139020  
 Func Obsc: 100 Econ %: 100 Other %: 100 Exception: 66330 Adjust: Adjust RMV: 0

I/O

Floors

Type	Class	Display Group	Floor Size	Beds	Baths	Yr Blt	Eff Yr Blt	Inventory	Exception: Y N
Metal Componet Bldg	5	Finished	3750	0	FB-1	2024	2024	AVG, GOOD, BATH, 1	

2 1/2 bath

Accessories

Description	Class	Size SqFt	Eff Yr Blt	RMV	Quantity
No accessory data available					



Add header

### Percent Good Calculator

This form is to assist with determining the blended Percent Good of a structure when there is an addition to the original structure. The calculated Percent Good will be entered into ORCATS as an Effective Year Built.

#### Using This Form:

Add the square footage of the addition to the Addition line. The addition will be calculated at 100% good. Add the original square footage and % Good value of the structure to the appropriate fields. The % Good value should represent the original structure based upon its condition without consideration to the addition.

The form will calculate an updated Percent Good value for the entire structure.

Account Number: 538828 Appraiser: \_\_\_\_\_ Date: \_\_\_\_\_

	Sq. Ft.	% Good	% of Whole	
Addition:	555	100%	21%	21%
Basement:				
First Floor:	2267	87%	50%	44%
Second Floor:	1270	87%	28%	25%
ATC:				
Total Sq. Ft.:	4492	100%	99%	- Updated % Good 2005

Sheet 1

# SKETCH/AREA TABLE ADDENDUM

## SUBJECT INFO

File No.: 538928 Parcel No.: 071E26C 00400  
 Property Address: 182 Silver Falls Dr SE  
 City: Silverton County: State: OR ZipCode: 97381  
 Owner:  
 Client: Client Address:  
 Appraiser Name: Inspection Date:

## SKETCH

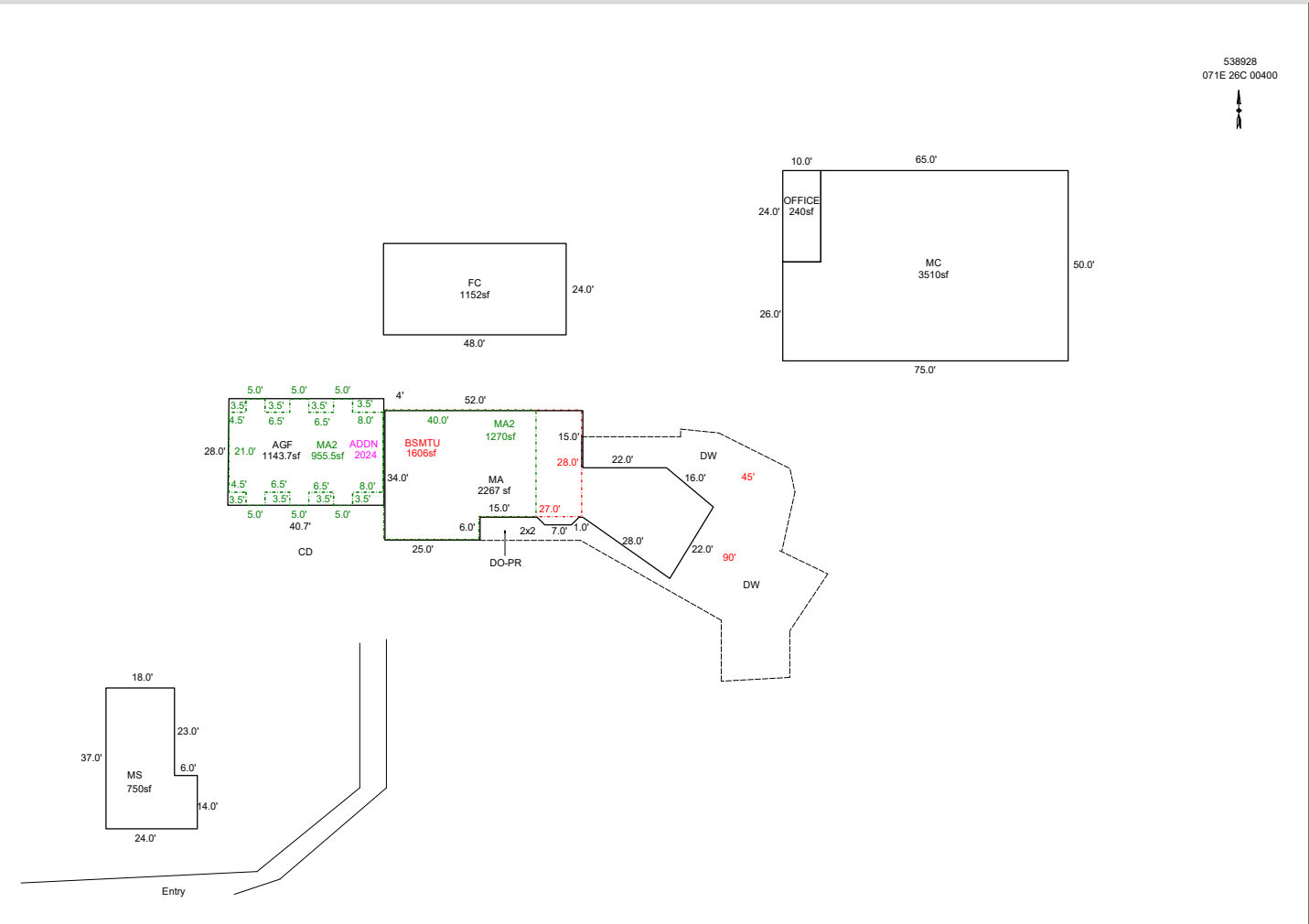

Sketch by ApexSketch

### AREA CALCULATIONS SUMMARY

Code	Description	Factor	Net Size	Perimeter	Net Totals
GBA1	MS	1.0	750.0	122.0	
	FC	1.0	1152.0	144.0	1902.0
GLA1	MA	1.0	2267.3	248.7	2267.3
GLA2	MA2	1.0	1270.0	148.0	1270.0
	MA2	1.0	955.5	165.0	955.5
BSMT	BSMTU	1.0	1606.0	172.0	1606.0
GAR	AGF	1.0	1143.7	137.7	1143.7
MA	MC	1.0	3510.0	250.0	
	OFFICE	1.0	240.0	68.0	3750.0
	Net LIVABLE	cnt	3 (rounded)		8,243
	Net BUILDING	cnt	2 (rounded)		1,902

### COMMENT TABLE 1

Apex 3/05/2012 Jane  
 UPDATED BY CLOBERG 11/12/24 24-007323 MA ADDN  
 UPDATED BY CLOBERG 12/30/24

### COMMENT TABLE 2

MLH 10/29/24

*MLH 11/18/25*

### COMMENT TABLE 3

TAGS L1

*TAGS L2*