

SKETCH/AREA TABLE ADDENDUM

SUBJECT INFO

File No.: 608954 Parcel No.: 092W28B001901
 Property Address: 13287 PICARD PL SE
 City: TURNER County: Marion State: OR ZipCode: 97392
 Owner:
 Client: Client Address:
 Appraiser Name: Inspection Date:

SKETCH

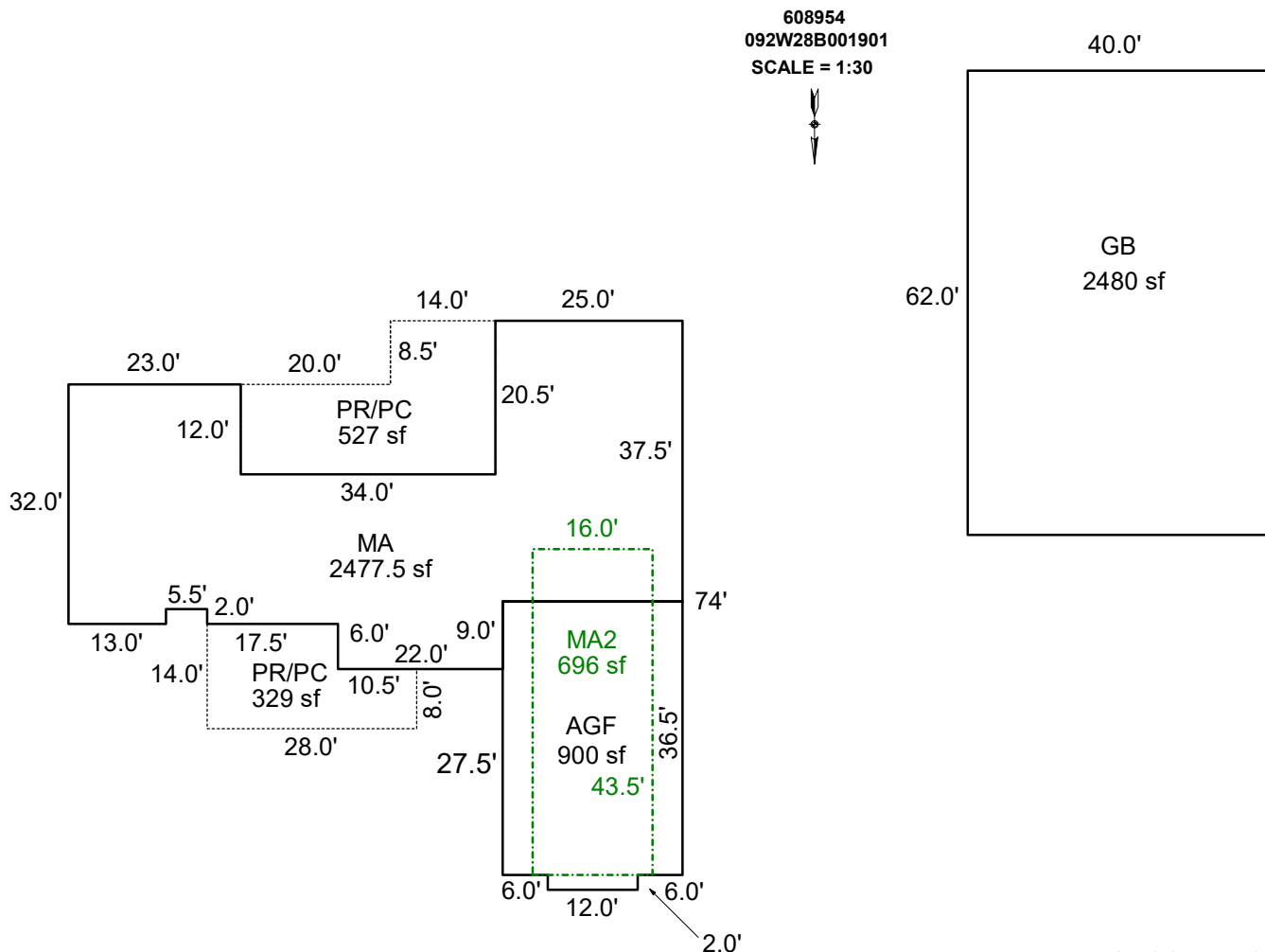

Sketch by ApexSketch

AREA CALCULATIONS SUMMARY						COMMENT TABLE 1	
Code	Description	Factor	Net Size	Perimeter	Net Totals		
GBA1	GB	1.0	2480.0	204.0	2480.0	APEX BY CLOBERG 06/17/2024 24-001516 MA UPDATED BY CLOBERG 08/05/24 24-001517 GB UPDATED BY CLOBERG 12/20/24 UPDATED BY CLOBERG 03/31/26	
GLA1	MA	1.0	2477.5	285.0	2477.5		
GLA2	MA2	1.0	696.0	119.0	696.0		
GAR	AGF	1.0	0.0	33.0			
	AGF	1.0	900.0	125.0	900.0		
P/P	PR/PC	1.0	527.0	109.0		COMMENT TABLE 2 MDL 10/14/24 GRH 01/13/25	
	PR/PC	1.0	329.0	84.0	856.0		
	Net LIVABLE	cnt	2 (rounded)		4,074		
	Net BUILDING	cnt	0 (rounded)		2,480		