

Summary

Lead Appr: MLH Clerk: \_\_\_\_\_ Lead Clerk: \_\_\_\_\_ Appr: MLH 3/13/26

Print Date: 9/26/2025

Acct ID: 547452 MTL: 071E11A002000 Date: 10/15/25 Appr: MLH Prop Class: 641 RMV Prop Class: 401 451  
Situs: 20354 EL ROMAR DR NE SCOTTS MILLS OR 97375 MaSaNh: 03 06 000 Unit: 107912 Year: 2025 1026

Last Date Appraised: 01/09/2025 Appraiser: MATTHEW HAMILTON Tag: Y N Tag info: 2026 - NEW CONSTRUCTION (Outbuilding)

Owner: BRONSON, DANIEL ERNEST 503 798 0286 Last Sales Date: 08/08/2022 Roll Type: R

Cycle Tag Sales Verification Other: \_\_\_\_\_ Inspection level: 1 2 3 4 LCB TTC INSP AV: 296481

RMV Land: 364900 RMV Imp: 520140 RMV Total: 885040 MAV: 294190 MSAV: 2291 SAV: 4441

Comment: 25-26: L2 1.9.25 MLH  
23-24: L3 04.25.23 CL owner said gate would be open but was not

NEW GB @ 100% close Tag

Input MLH 2/12/26 Forest OK

Notations

RP/MS	Code	Description
RP	DFL	DESIGNATED FORESTLAND

CWO 3/6/26

OSDs

Count	Code	Description	RMV	Code Area	Exception
1	MKTA	OSD - AVERAGE	50000	04500	0

Land

Site: 1 Code Area: 04500 Size: 1.00 Acres Use Code: 005 Zone: REST SAV Use: Exception: 0  
 Class: 4BDSS Value Source: Market Homesite Description: FOUR BENCH DRY SPECIAL SOUTH RMV: 62980 Exception: Y N  
 Adjustment(s): Fire Patrol: SA004 Description: FIRE PATROL  
 Comments: 25-26: Land classes ok

Site: 2 Code Area: 04500 Size: 4.00 Acres Use Code: 005 Zone: REST SAV Use: 011 Exception: 0  
 Class: FTLG Value Source: Designated Forest Land Description: DFL Class C RMV: 251920 Exception: Y N  
 Adjustment(s): Fire Patrol: SA004 Description: FIRE PATROL  
 Comments: Liability year - 1977 / 400028

Improvements - Residence / Manufactured Structures

Bldg: 1 Code Area: 04500 Stat Class: 154 Year Blt: 1976 Eff Year Blt: 2000 Sq.Ft: 1924 % Complete: 100.00  
 Desc: Multi Story above grade with basement Dimensions: RMV: 456860  
 Func Obsc: 100 Econ %: 100 Other %: 100 Exception: 0 Adjust: Adjust RMV: 0

Floors

Type	Class	Display Group	Floor Size	Beds	Baths	Yr Blt	Eff Yr Blt	Inventory	Exception
First Floor	5	Finished	962	1	FB-1	1976	2000	FP - 1, KIT, HVAC, ROOF, BATH - 1	Y N
Attic	5	Unfinished	250	0	0	1976	2000		Y N
Basement	5	Finished	962	1	FB-1	1976	2000	HVAC, BATH - 1	Y N

Accessories

Description	Class	Size SqFt	Eff Yr Blt	RMV	Quantity
No accessory data available					

VISA

Bldg: 6 Code Area: 04500 Stat Class: 108 Year Blt: Eff Year Blt: Sq.Ft: 0 % Complete: 100.00  
 Desc: Residential Other Improvements Dimensions: RMV: 0  
 Func Obsc: 100 Econ %: 100 Other %: 100 Exception: 0 Adjust: Adjust RMV: 0

Floors

Type	Class	Display Group	Floor Size	Beds	Baths	Yr Blt	Eff Yr Blt	Inventory	Exception
No floor data available									

Delete

Accessories

Description	Class	Size SqFt	Eff Yr Blt	RMV	Quantity
GARDEN SHED	4	80	0	1280	0

Bldg: 7 Code Area: 04500 Stat Class: 107 Year Blt: Eff Year Blt: 2000 Sq.Ft: 0 % Complete: 100.00  
 Desc: Yard Improvements Dimensions: RMV: 41600  
 Func Obsc: 100 Econ %: 100 Other %: 100 Exception: 0 Adjust: Adjust RMV: 0

Floors

Type	Class	Display Group	Floor Size	Beds	Baths	Yr Blt	Eff Yr Blt	Inventory	Exception
No floor data available									

MOVE MAJ

Accessories

Description	Class	Size SqFt	Eff Yr Blt	RMV	Quantity
YARD IMPROVEMENTS AVERAGE	5	0	2000	39248	1

**Improvements - Accessory Buildings**

Bldg: 4 Code Area: 04500 Stat Class: 351 Year Blt: 1997 Eff Year Blt: 2007 Sq.Ft: 1080 % Complete: 100.00  
 Desc: General Purpose Building (GB) Dimensions: 36x30 RMV: 17290  
 Func Obsc: 100 Econ %: 100 Other %: 100 Exception: 0 Adjust: Adjust RMV: 0

N/C

**Floors**

Type	Class	Display Group	Floor Size	Beds	Baths	Yr Blt	Eff Yr Blt	Inventory	Exception: Y N
General Purpose Bldg	5	Finished	1080	0	0	1997	2007	AVG	

**Accessories**

Description	Class	Size SqFt	Eff Yr Blt	RMV	Quantity
No accessory data available					

Bldg: 5 Code Area: 04500 Stat Class: 355 Year Blt: 1978 Eff Year Blt: 1978 Sq.Ft: 120 % Complete: 100.00  
 Desc: Lean-to Heavy (LTH) Dimensions: 12x10 RMV: 160  
 Func Obsc: 100 Econ %: 100 Other %: 100 Exception: 0 Adjust: Adjust RMV: 0

N/C

**Floors**

Type	Class	Display Group	Floor Size	Beds	Baths	Yr Blt	Eff Yr Blt	Inventory	Exception: Y N
Lean-to Heavy Duty	4	Finished	120	0	0	1978	1978		

**Accessories**

Description	Class	Size SqFt	Eff Yr Blt	RMV	Quantity
No accessory data available					

Bldg: 8 Code Area: 04500 Stat Class: 321 Year Blt: 2018 Eff Year Blt: 2018 Sq.Ft: 540 % Complete: 100.00  
 Desc: Hay Cover (HC) Dimensions: 30x18 RMV: 4230  
 Func Obsc: 100 Econ %: 100 Other %: 100 Exception: 0 Adjust: Adjust RMV: 0

N/C

**Floors**

Type	Class	Display Group	Floor Size	Beds	Baths	Yr Blt	Eff Yr Blt	Inventory	Exception: Y N
Hay Cover	5	Finished	540	0	0	2018	2018	FAIR	

**Accessories**

Description	Class	Size SqFt	Eff Yr Blt	RMV	Quantity
No accessory data available					

**Farm Notes**

2025FARM

1/9/25: Inspected by MLH L2 during tags, forest use ok

351 GB 5 2025 36x50 AVE NEW

# SKETCH/AREA TABLE ADDENDUM

## SUBJECT INFO

File No.: 547452 Parcel No.: 071E11A 02000  
 Property Address: 20354 EL ROMAR DR NE  
 City: SCOTTS MILLS County: MARION State: OR ZipCode: 97375  
 Owner:  
 Client: Client Address:  
 Appraiser Name: Inspection Date:

## SKETCH

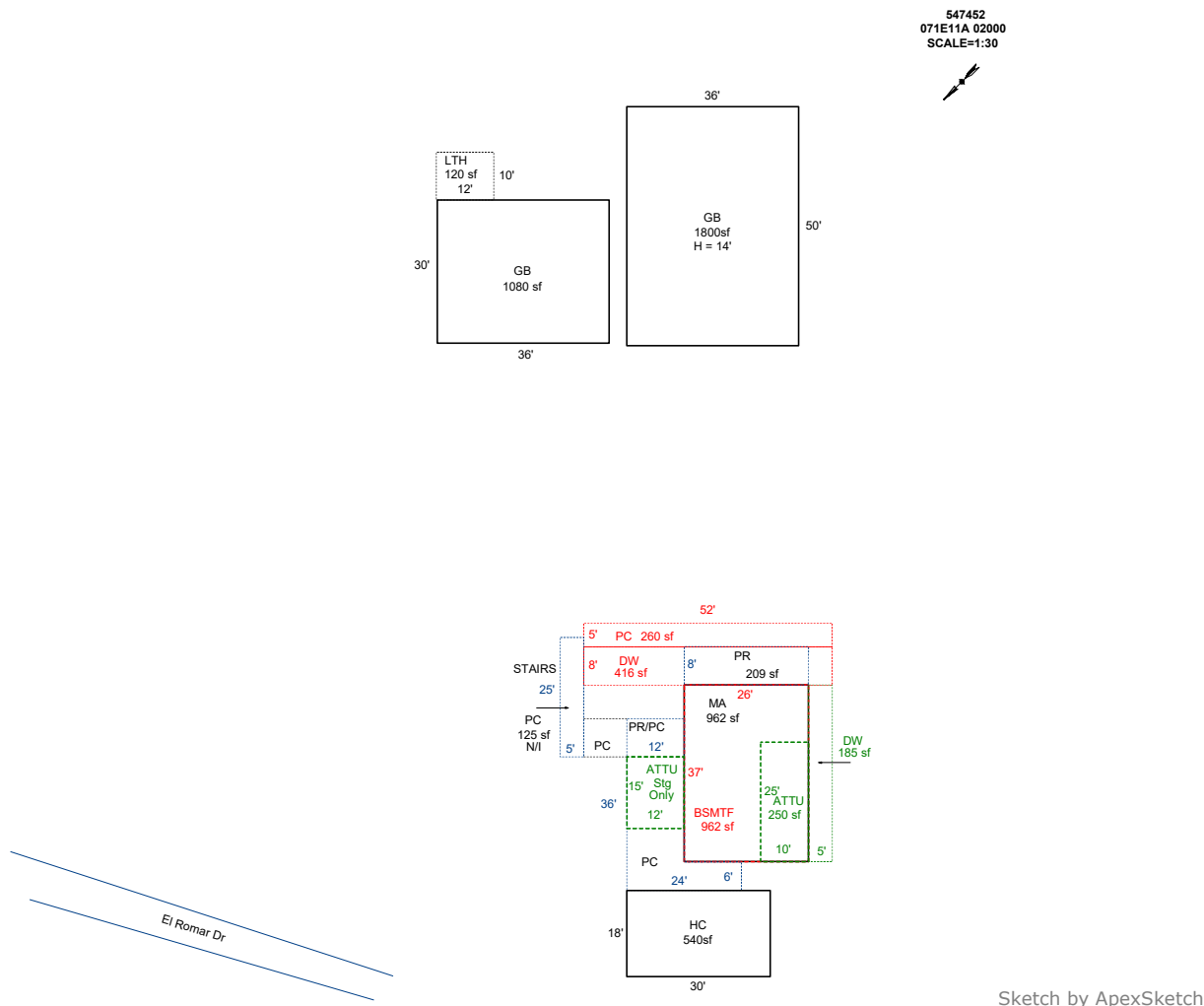

### AREA CALCULATIONS SUMMARY

Code	Description	Factor	Net Size	Perimeter	Net Totals
GBA1	GB	1.0	1080.0	132.0	
	LTH	1.0	120.0	44.0	
	GB	1.0	1800.0	172.0	
	HC	1.0	540.0	96.0	3540.0
GLA1	MA	1.0	962.0	126.0	962.0
GLA2	ATTU	1.0	250.0	70.0	250.0
BSMT	BSMTF	1.0	962.0	126.0	962.0
P/P	PC	1.0	504.0	120.0	
	PC	1.0	260.0	114.0	
	PC	1.0	125.0	60.0	
	PR	1.0	208.7	68.0	
	DW	1.0	185.0	84.0	
	DW	1.0	416.0	120.0	1698.7
	Net LIVABLE	cnt	0 (rounded)		1,212
	Net BUILDING	cnt	0 (rounded)		3,540

### COMMENT TABLE 1

Apex 10/21/2011 Jane  
 UPDATED BY JRONDEMA 9/14/18  
 UPDATED BY CLOBERG 11/19/24 24-006325 GB  
 UPDATED BY CLOBERG 03/16/26

### COMMENT TABLE 2

MLH 10/15/25

### COMMENT TABLE 3

TAGS L4

# SKETCH/AREA TABLE ADDENDUM

## SUBJECT INFO

File No.: 547452 Parcel No.: 071E11A 02000  
 Property Address: 20354 EL ROMAR DR NE  
 City: SCOTTS MILLS County: MARION State: OR ZipCode: 97375  
 Owner:  
 Client: Client Address:  
 Appraiser Name: Inspection Date:

## SKETCH

547452  
071E11A 02000  
SCALE=1:30

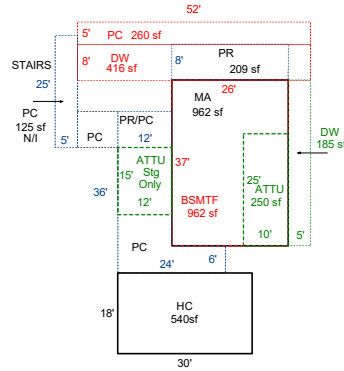
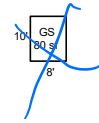
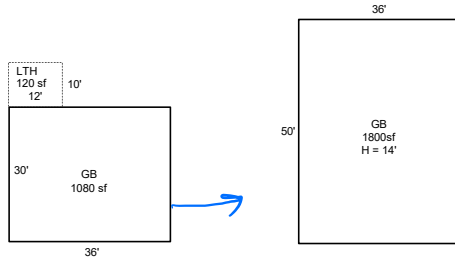

Sketch by ApexSketch

### AREA CALCULATIONS SUMMARY

Code	Description	Factor	Net Size	Perimeter	Net Totals
GBA1	GB	1.0	1080.0	132.0	
	LTH	1.0	120.0	44.0	
	GB	1.0	1800.0	172.0	
	HC	1.0	540.0	96.0	3540.0
GLA1	MA	1.0	962.0	126.0	962.0
GLA2	ATTU	1.0	250.0	70.0	250.0
BSMT	BSMTF	1.0	962.0	126.0	962.0
OTH	GS	1.0	80.0	36.0	80.0
P/P	PC	1.0	504.0	120.0	
	PC	1.0	260.0	114.0	
	PC	1.0	125.0	60.0	
	PR	1.0	208.7	68.0	
	DW	1.0	185.0	84.0	
	DW	1.0	416.0	120.0	1698.7
	Net LIVABLE	cnt	0 (rounded)		1,212
	Net BUILDING	cnt	4 (rounded)		3,540

### COMMENT TABLE 1

Apex 10/21/2011 Jane  
 UPDATED BY JRONDEMA 9/14/18  
 UPDATED BY CLOBERG 11/19/24 24-006325 GB

### COMMENT TABLE 2

10/15/25 MLH

### COMMENT TABLE 3

Tags L4