

Summary

Lead Appr: MLH Clerk: _____ Lead Clerk: _____ Appr: **MLH 3/13/26**

Print Date:

12/26/2025

Acct ID: 539198 MTL: 071E35A00060 Date: 3/2/26 Appr: MLH Prop Class: 641 RMV Prop Class: 401457
Situs: 20131 BRIDGE CREEK RD SE SILVERTON OR 97381 MaSaNh: 03 06 001 Unit: 64357 Year: 2026

Last Date Appraised: 05/25/2021 Appraiser: MATTHEW HAMILTON Tag: Y N Tag info:

Owner: ADAMS, KIMBERLY Last Sales Date: 10/24/2025 Roll Type: R

Cycle Tag: Sales Verification Other: _____ Inspection level: 1 2 3 4 LCB TTO INSP AV: 123991

RMV Land: 401130 RMV Imp: 168040 RMV Total: 569170 MAV: 119290 MSAV: 4701 SAV: 8848

Comment: LEVEL 4 5.25.21 CL10

MLS 832467
DOM 75
Sales Code 22

update inventory

Input MLH 3/2/26

Notations

RP/MS	Code	Description
RP	DFL	DESIGNATED FORESTLAND

Forest - looks like about an acre of trees is missing

OSDs

Count	Code	Description	RMV	Code Area	Exception
2	MKTA	OSD - AVERAGE	55000	04480	0

Land

CWO 3/6/26 L4 Send inquiry letter about 1.8 acres harvested and not replanted

Site: 1 Code Area: 04480 Size: 1.00 Acres Use Code: 005 Zone: REST SAV Use: Exception: 0
 Class: DFL Value Source: Market Homesite Description: RMV: 38590 Exception: Y N
 Adjustment(s): Fire Patrol: SA004 Description: FIRE PATROL
 Comments: 00400088, 01-02: F00-741 ACREAGE CORRECTION 05-06: RECALC SETUP;#17

Site: 2 Code Area: 04480 Size: 4.00 Acres Use Code: 005 Zone: REST SAV Use: 011 Exception: 0
 Class: FTLIC Value Source: Designated Forest Land Description: DFL Class C RMV: 154350 Exception: Y N
 Adjustment(s): Fire Patrol: SA004 Description: FIRE PATROL
 Comments: Liability year - 1983 / 00400088

Site: 3 Code Area: 04480 Size: 3.97 Acres Use Code: 005 Zone: REST SAV Use: 011 Exception: 0
 Class: FTLIC Value Source: Designated Forest Land Description: DFL Class C RMV: 153190 Exception: Y N
 Adjustment(s): Fire Patrol: SA004 Description: FIRE PATROL
 Comments: Liability year - 1983 / 00400088, 01-02 F00-741 ACREAGE CORRECTION 05-06: RECALC SETUP;#17

Improvements - Residence / Manufactured Structures

Bldg: 1 Code Area: 04480 Stat Class: 131 Year Blt: 1946 Eff Year Blt: 1998 Sq.Ft: 1520 % Complete: 100.00
 Desc: One Story Only Dimensions: RMV: 152140
 Func Obsc: 100 Econ %: 100 Other %: 100 Exception: 0 Adjust: Adjust RMV: 0

I/O

Floors

Type	Class	Display Group	Floor Size	Beds	Baths	Yr Blt	Eff Yr Blt	Inventory	Exception
First Floor	3	Finished	1520	3	FB-1/ HB-1	1946	1998	BATH - 1, BTH - 1, FP - 1, HVAC+, KIT, ROOF	Y N

Accessories

Description	Class	Size SqFt	Eff Yr Blt	RMV	Quantity	Exception
DECK	3	54	1998	1034	1	Y N
DECK	3	80	1998	1531	1	Y N
DECK	3	156	1998	2986	1	Y N
ROOF EXTENSION OR PATIO COVER	3	32	1998	807	1	Y N
ROOF EXTENSION OR PATIO COVER	3	32	1998	807	1	Y N

V I 3 A

Improvements - Accessory Buildings

Bldg: 2 Code Area: 04480 Stat Class: 351 Year Blt: 2004 Eff Year Blt: 2004 Sq.Ft: 1152 % Complete: 100.00
 Desc: General Purpose Building (GB) Dimensions: 48x24 RMV: 15900
 Func Obsc: 100 Econ %: 100 Other %: 100 Exception: 0 Adjust: Adjust RMV: 0

I/O

Floors

Type	Class	Display Group	Floor Size	Beds	Baths	Yr Blt	Eff Yr Blt	Inventory	Exception
General Purpose Bldg	5	Finished	1152	0	0	2004	2004	FAIR <u>Ave</u>	Y N

Accessories

Description	Class	Size SqFt	Eff Yr Blt	RMV	Quantity
No accessory data available					

355 LTH 6x12 2000 I/O
354 LTL 10x14 2000 I/O

SKETCH/AREA TABLE ADDENDUM

SUBJECT INFO

File No.: 539198 Parcel No.: 071E35A 00600
 Property Address: 20131 BRIDGE CREEK RD SE
 City: SILVERTON County: State: OR ZipCode: 97381
 Owner:
 Client: Client Address:
 Appraiser Name: Inspection Date:

SKETCH

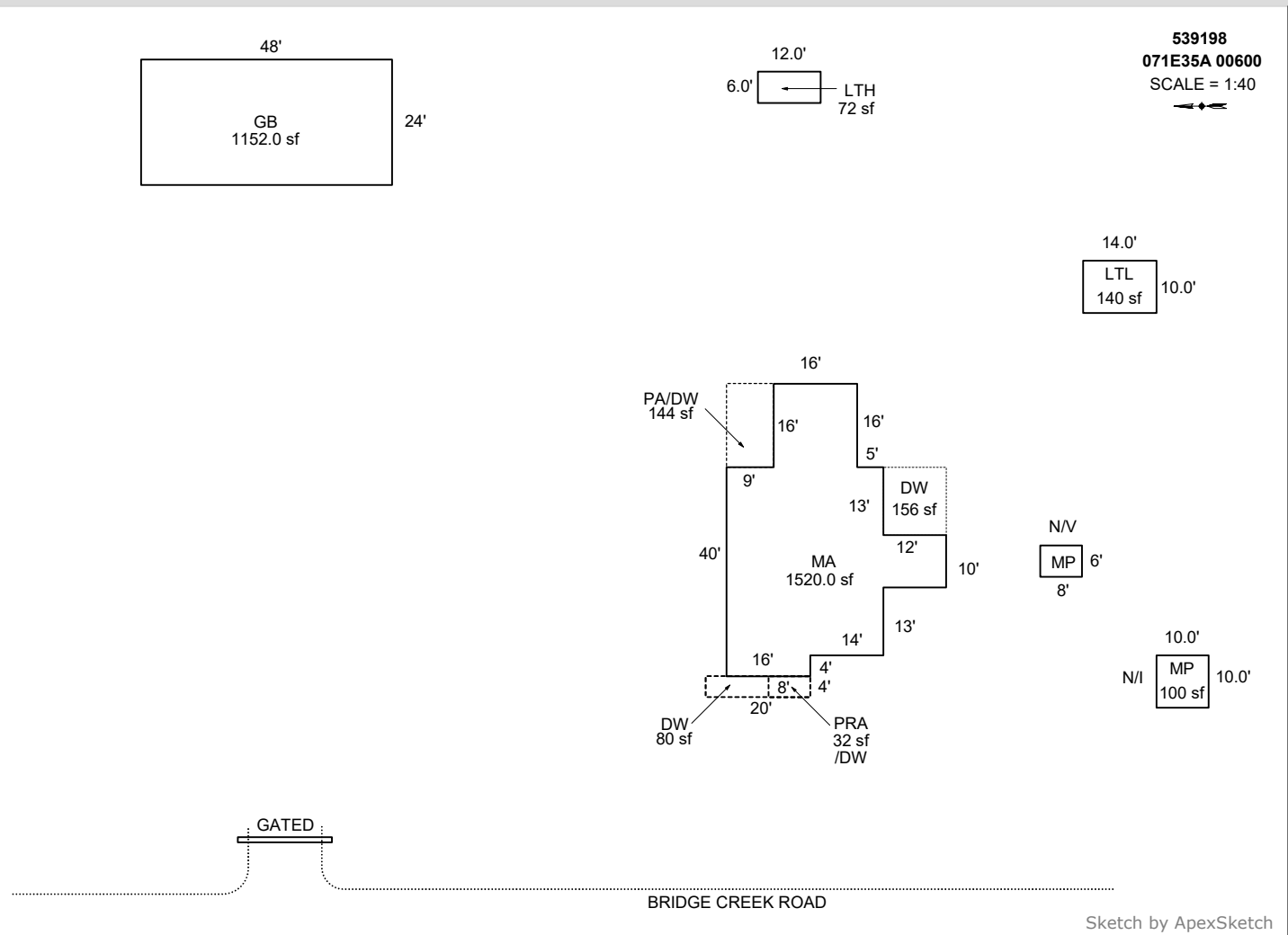

Sketch by ApexSketch

AREA CALCULATIONS SUMMARY						COMMENT TABLE 1					
Code	Description	Factor	Net Size	Perimeter	Net Totals						
GBA1	MP	1.0	48.0	28.0		Apex 11/15/2011 Jane UPDATED BY CJURAN 01/05/2022 UPDATED BY CLOBERG 03/16/26					
	GB	1.0	1152.0	144.0	1200.0						
GLA1	MA	1.0	1520.0	196.0	1520.0						
LTH	LTH	1.0	72.0	36.0	72.0						
LTL	LTL	1.0	140.0	48.0	140.0						
MP	MP	1.0	100.0	40.0	100.0						
P/P	DW	1.0	156.0	50.0							
	PA/DW	1.0	144.0	50.0							
	DW	1.0	80.0	48.0							
	PRA	1.0	32.0	24.0	412.0						
	Net LIVABLE	cnt	3 (rounded)		1,832	<table border="1" style="width: 100%; border-collapse: collapse;"> <thead> <tr> <th style="text-align: center;">COMMENT TABLE 2</th> <th style="text-align: center;">COMMENT TABLE 3</th> </tr> </thead> <tbody> <tr> <td>#10 CL 05/25/2021 MLH 03/02/26</td> <td>SV L4 SV L4</td> </tr> </tbody> </table>		COMMENT TABLE 2	COMMENT TABLE 3	#10 CL 05/25/2021 MLH 03/02/26	SV L4 SV L4
COMMENT TABLE 2	COMMENT TABLE 3										
#10 CL 05/25/2021 MLH 03/02/26	SV L4 SV L4										
	Net BUILDING	cnt	0 (rounded)		1,200						

SKETCH/AREA TABLE ADDENDUM

SUBJECT INFO

File No.: 539198 Parcel No.: 071E35A 00600
 Property Address: 20131 BRIDGE CREEK RD SE
 City: SILVERTON County: State: OR ZipCode: 97381
 Owner:
 Client: Client Address:
 Appraiser Name: Inspection Date:

SKETCH

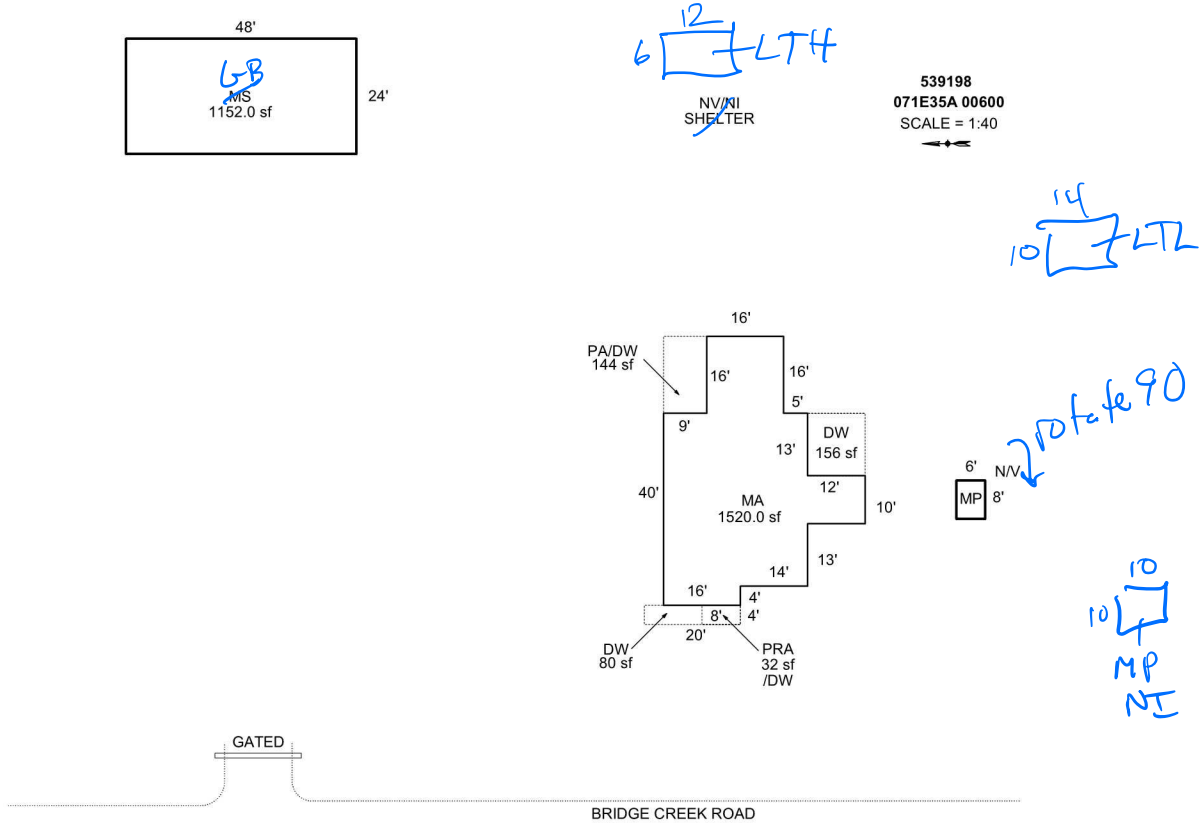

Sketch by Apex Sketch

AREA CALCULATIONS SUMMARY

Code	Description	Factor	Net Size	Perimeter	Net Totals
GBA1	MP	1.0	48.0	28.0	
	MS	1.0	1152.0	144.0	1200.0
GLA1	MA	1.0	1520.0	196.0	1520.0
P/P	DW	1.0	156.0	50.0	
	PA/DW	1.0	144.0	50.0	
	DW	1.0	80.0	48.0	
	PRA	1.0	32.0	24.0	412.0

COMMENT TABLE 1

Apex 11/15/2011 Jane
 UPDATED BY CJURAN 01/05/2022

COMMENT TABLE 2

#10 CL 05/25/2021
 MLH 3/2/20

COMMENT TABLE 3

SV L4
 SV L4

Net LIVABLE cnt 1 (rounded) 1,520
 Net BUILDING cnt 2 (rounded) 1,200