

Summary

Lead Appr: WW 12/3

Clerk: _____

Lead Clerk: _____

Appr: MLH 1/2/26

Print Date:

9/29/2025

Acct ID: 538304

MTL: 071E040001100

Date: 10/2/25

Appr: MLH

Prop Class: 551

RMV Prop Class: 551

45/

Situs: 4194 DAVIS CREEK RD NE SILVERTON OR 97381

MaSaNh: 03 06 000

Unit: 65776

Year: 2025

2026

Last Date Appraised: 08/30/2016

Appraiser: MATTHEW HAMILTON

Tag: Y N

Tag info:

Owner: CEREMUGA, JOSEPH JOHN III

Last Sales Date: 05/02/2025

Roll Type: R

Cycle Tag Sales Verification Other: _____

Inspection level: 1 2 3 4 LCB TTO INSP

AV: 244081

RMV Land: 82000

RMV Imp: 442140

RMV Total: 524140

MAV: 229660

MSAV: 14421

SAV: 21473

Comment: MLS 821895
DOM 217

update Inventory

Notations

Sales Code 15 group sale w/ 538303

Input MLH

12/1/25

RP/MS	Code	Description
RP	ZONED	FARM EFU ZONED

OSDs

Count	Code	Description	RMV	Code Area	Exception
1	SAA	SA OSD - AVERAGE	50000	04480	0

Land

Site: 2	Code Area: 04480	Size: 1.00 Acres	Use Code: 005	Zone: REST	SAV Use: 011	Exception: 0
Class: 0	Value Source: Farm Homesite	Description:	RMV: 16080	Exception: Y N		
Adjustment(s):	Fire Patrol:		Description:			
Comments: Liability year - 2009 / 00-01: UPDATED MARKET VALUE, 400088						

Site: 3	Code Area: 04480	Size: 0.99 Acres	Use Code: 005	Zone: REST	SAV Use: 011	Exception: 0
Class: 4HD	Value Source: Farm Use - EFU	Description: FOUR HILL DRY	RMV: 15920	Exception: Y N		
Adjustment(s):	Fire Patrol:		Description:			
Comments: Liability year - 1981 / 08-09: EIGHT BENCH PROJ - CHG FROM EIGHT BENCH TO FOUR BENCH DRY// 00-01: UPDATED MARKET VALUE, 400088						

Improvements - Residence / Manufactured Structures

Bldg: 1	Code Area: 04480	Stat Class: 143	Year Blt: 1971	Eff Year Blt: 1980	Sq.Ft: 2494	% Complete: 100.00
Desc: One Story with basement	Dimensions:		RMV: 420390			
Func Obsc: 100	Econ %: 100	Other %: 100	Exception: 0	Adjust:	Adjust RMV: 0	I/O

Floors

Type	Class	Display Group	Floor Size	Beds	Baths	Yr Blt	Eff Yr Blt	Inventory	Exception
First Floor	4	Finished	1528	2	FB-2	1971	1980	KIT-, FP - 1, HVAC, ROOF, BATH - 2	Y N
Basement	4	Finished	966	3	FB-1	1971	1980	HVAC, BATH - 1, FP	Y N
Garage Basement	4	Unfinished	550	0	0	1971	1980		Y N

Accessories

Description	Class	Size SqFt	Eff Yr Blt	RMV	Quantity	Exception
ASPHALT DRIVEWAY Part of UT	4	1875	1948	3713	1	Y N
YARD IMPROVEMENTS GOOD	4	1	1980	33384	1	Y N

Improvements - Accessory Buildings

Bldg: 2	Code Area: 04480	Stat Class: 353	Year Blt: 1989	Eff Year Blt: 1989	Sq.Ft: 1008	% Complete: 100.00
Desc: Machine Shed (MS)	Dimensions:		RMV: 4650			
Func Obsc: 100	Econ %: 100	Other %: 100	Exception: 0	Adjust:	Adjust RMV: 0	I/O

Floors

Type	Class	Display Group	Floor Size	Beds	Baths	Yr Blt	Eff Yr Blt	Inventory	Exception
Machine Shed	5	Finished	1008	0	0	1989	1989	FAIR	Y N

Accessories

Description	Class	Size SqFt	Eff Yr Blt	RMV	Quantity	Exception
No accessory data available						

Bldg: 3	Code Area: 04480	Stat Class: 351	Year Blt: 1989	Eff Year Blt: 1989	Sq.Ft: 1314	% Complete: 100.00
Desc: General Purpose Building (GB)	Dimensions: 40x30		RMV: 8500			
Func Obsc: 100	Econ %: 100	Other %: 100	Exception: 0	Adjust:	Adjust RMV: 0	I/O

Floors

Type	Class	Display Group	Floor Size	Beds	Baths	Yr Blt	Eff Yr Blt	Inventory	Exception
General Purpose Bldg	5	Finished	1314	0	0	1989	1989	FAIR	Y N

Accessories

Description	Class	Size SqFt	Eff Yr Blt	RMV	Quantity
No accessory data available					

Bldg: 4 Code Area: 04480 Stat Class: 341 Year Blt: 1989 Eff Year Blt: 1989²⁰⁰⁰ Sq.Ft: 312 % Complete: 100.00
 Desc: Multi Purpose Shed (MP) Dimensions: 24x13 RMV: 3740
 Func Obsc: 100 Econ %: 100 Other %: 100 Exception: 0 Adjust: Adjust RMV: 0 I/O

Floors

Type	Class	Display Group	Floor Size	Beds	Baths	Yr Blt	Eff Yr Blt	Inventory	Exception: Y N
Multi-Purpose Bldg	6	Finished	312	0	0	1989	1989	FAIR AJC 1/10/11	

Accessories

Description	Class	Size SqFt	Eff Yr Blt	RMV	Quantity
No accessory data available					

Bldg: 5 Code Area: 04480 Stat Class: 355 Year Blt: 1989 Eff Year Blt: 1989²⁰⁰⁰ Sq.Ft: 264 % Complete: 100.00
 Desc: Lean-to Heavy (LTH) Dimensions: 24x11 RMV: 530
 Func Obsc: 100 Econ %: 100 Other %: 100 Exception: 0 Adjust: Adjust RMV: 0 I/O

Floors

Type	Class	Display Group	Floor Size	Beds	Baths	Yr Blt	Eff Yr Blt	Inventory	Exception: Y N
Lean-to Heavy Duty	4	Finished	264	0	0	1989	1989		

Accessories

Description	Class	Size SqFt	Eff Yr Blt	RMV	Quantity
No accessory data available					

Bldg: 6 Code Area: 04480 Stat Class: 341 Year Blt: 1989 Eff Year Blt: 1989²⁰⁰⁰ Sq.Ft: 144 % Complete: 100.00
 Desc: Multi Purpose Shed (MP) Dimensions: 12x12 RMV: 2170
 Func Obsc: 100 Econ %: 100 Other %: 100 Exception: 0 Adjust: Adjust RMV: 0 I/O

Floors

Type	Class	Display Group	Floor Size	Beds	Baths	Yr Blt	Eff Yr Blt	Inventory	Exception: Y N
Multi-Purpose Bldg	6	Finished	144	0	0	1989	1989	FAIR	

Accessories

Description	Class	Size SqFt	Eff Yr Blt	RMV	Quantity
No accessory data available					

Bldg: 7 Code Area: 04480 Stat Class: 355 Year Blt: 1979 Eff Year Blt: 1979 Sq.Ft: 440 % Complete: 100.00
 Desc: Lean-to Heavy (LTH) Dimensions: RMV: 590
 Func Obsc: 100 Econ %: 100 Other %: 100 Exception: 0 Adjust: Adjust RMV: 0

Floors

Type	Class	Display Group	Floor Size	Beds	Baths	Yr Blt	Eff Yr Blt	Inventory	Exception: Y N
Lean-to Heavy Duty	4	Finished	440	0	0	1979	1979	Gone	

Accessories

Description	Class	Size SqFt	Eff Yr Blt	RMV	Quantity
No accessory data available					

Bldg: 8 Code Area: 04480 Stat Class: 355 Year Blt: 1974 Eff Year Blt: 1974 Sq.Ft: 200 % Complete: 100.00
 Desc: Lean-to Heavy (LTH) Dimensions: 20x10 RMV: 270
 Func Obsc: 100 Econ %: 100 Other %: 100 Exception: 0 Adjust: Adjust RMV: 0

Floors

Type	Class	Display Group	Floor Size	Beds	Baths	Yr Blt	Eff Yr Blt	Inventory	Exception: Y N
Lean-to Heavy Duty	4	Finished	200	0	0	1974	1974	Gone	

Accessories

Description	Class	Size SqFt	Eff Yr Blt	RMV	Quantity
No accessory data available					

Bldg: 9 Code Area: 04480 Stat Class: 355 Year Blt: 2005 Eff Year Blt: 1995²⁰⁰⁰ Sq.Ft: 420 % Complete: 100.00
 Desc: Lean-to Heavy (LTH) MS Dimensions: 14x30 RMV: 1190
 Func Obsc: 100 Econ %: 100 Other %: 100 Exception: 0 Adjust: Adjust RMV: 0 I/O

Floors

Type	Class	Display Group	Floor Size	Beds	Baths	Yr Blt	Eff Yr Blt	Inventory	Exception: Y N
Lean-to Heavy Duty	4	Finished	420	0	0	2005	1995	Fair	

Accessories

Description	Class	Size SqFt	Eff Yr Blt	RMV	Quantity
No accessory data available					

Bldg: 10 Code Area: 04480 Stat Class: 354 Year Blt: 1980 Eff Year Blt: 1980²⁰⁰⁰ Sq.Ft: 140 % Complete: 100.00
 Desc: Lean-to Light (LTL) Dimensions: 14x10 RMV: 110
 Func Obsc: 100 Econ %: 100 Other %: 100 Exception: 0 Adjust: Adjust RMV: 0

I/O

Floors

Type	Class	Display Group	Floor Size	Beds	Baths	Yr Blt	Eff Yr Blt	Inventory
Lean-to Light Duty	4	Finished	140	0	0	1980	1980	Exception: Y N

Accessories

Description	Class	Size SqFt	Eff Yr Blt	RMV	Quantity
No accessory data available					

354 LTL 10x18 2000 I/O

SKETCH/AREA TABLE ADDENDUM

SUBJECT INFO

File No.: 538304 Parcel No.: 071E04 01100
 Property Address: 4194 DAVIS CREEK RD NE
 City: SILVERTON County: MARION State: OR ZipCode: 97381
 Owner:
 Client Address:
 Appraiser Name: Inspection Date:

SKETCH

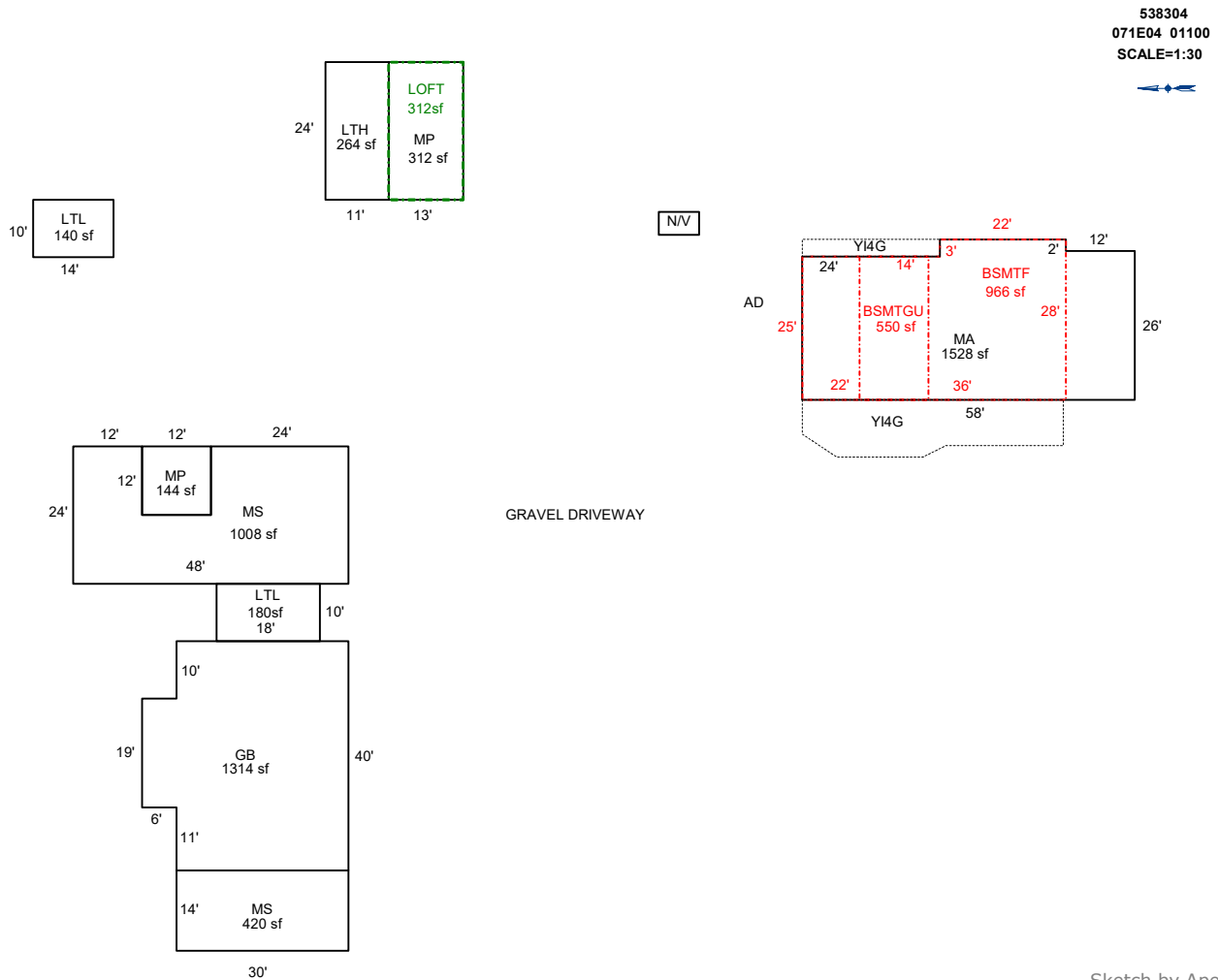

AREA CALCULATIONS SUMMARY

Code	Description	Factor	Net Size	Perimeter	Net Totals
GBA1	LTH	1.0	264.0	70.0	
	LTL	1.0	140.0	48.0	
	MS	1.0	1008.0	168.0	
	MP	1.0	144.0	48.0	
	GB	1.0	1314.0	152.0	
	MS	1.0	420.0	88.0	
GLA1	MP	1.0	312.0	74.0	3602.0
	MA	1.0	1528.0	172.0	1528.0
ATTF	LOFT	1.0	312.0	74.0	312.0
BSMT	BSMTF	1.0	966.0	128.0	
	BSMTGU	1.0	550.0	94.0	1516.0
LTL	LTL	1.0	180.0	56.0	180.0
P/P	YI4G	1.0	72.0	54.0	
	YI4G	1.0	398.0	106.7	470.0
	Net LIVABLE	cnt	1 (rounded)		1,708
	Net BUILDING	cnt	1 (rounded)		3,914

COMMENT TABLE 1

Apex 10/19/2012 Jane
 UPDATED BY JRONDEMA 9/12/16
 UPDATED BY CLOBERG 01/13/26

COMMENT TABLE 2

8.30.16 SR #94 S.V.
 MLH 10/21/25

COMMENT TABLE 3

SV L4

SKETCH/AREA TABLE ADDENDUM

Parcel No 071E04 01100

File No R38304

Property Address 4194 DAVIS CREEK RD NE

City SILVERTON

County MARION

State OR

Zip 97381

Owner

Client

Appraiser Name

SUBJECT

IMPROVEMENTS SKETCH

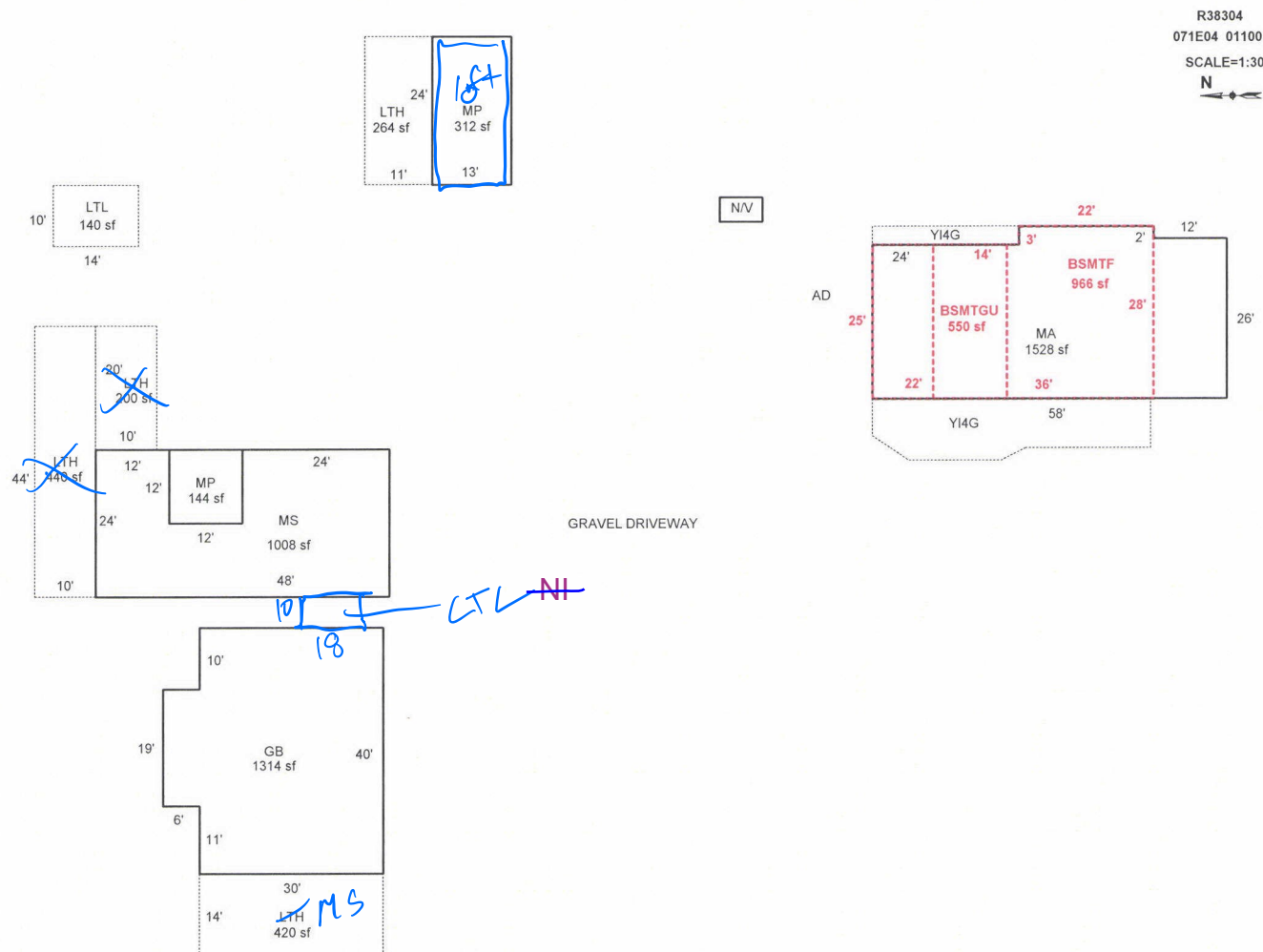

Scale: 1" = 30'

AREA CALCULATIONS

AREA CALCULATIONS SUMMARY

Code	Description	Factor	Net Size	Perimeter	Net Totals	
GLA1	MA	1.00	1528	172	1528	
GBA1	LTH	1.00	264	70		
	LTL	1.00	140	48		
	MS	1.00	1008	168		
	MP	1.00	144	48		
	LTH	1.00	200	60		
	LTH	1.00	440	108		
	GB	1.00	1314	152		
	LTH	1.00	420	88		
	MP	1.00	312	74		
BSMT	BSMTF	1.00	966	128		4242
	BSMTGU	1.00	550	94		1516
P/P	YI4G	1.00	72	54		
	YI4G	1.00	398	107		470
Net LIVABLE Area		(rounded w/ factors)			1528	
Net BUILDING Area		(rounded w/ factors)			4242	

Comment Table 1

Apex 10/19/2012 Jane
UPDATED BY JRONDEMA 9/12/16

Comment Table 2

8.30.16 SR #94 S.V.
MLH 10/2/25

Comment Table 3

SU LY