

Summary

Lead Appr: WW Clerk: _____ Lead Clerk: _____ Appr: MLH 3/5/26

Print Date: 9/26/2025

Acct ID: 521115 MTL: 071W050001500 Date: 2/26/26 Appr: MLH Prop Class: 551 RMV Prop Class: 451
Situs: 10833 SELAH SPRINGS RD NE SILVERTON OR 97381 MaSaNh: 03 06 000 Unit: 146864 Year: 2025

Last Date Appraised: 11/15/2024 Appraiser: MATTHEW HAMILTON Tag: Y (M) Tag info: 2026 - Tags/Permit (Demolished)

Owner: DAVIS, JESSE Last Sales Date: _____ Roll Type: R

Cycle (Tag) Sales Verification Other: _____ Inspection level: 1 2 3 4 LCB TTO INSP AV: 191617

RMV Land: 458100 RMV Imp: 322920 RMV Total: 781020 MAV: 144360 MSAV: 26497 SAV: 69751

Comment: 25-26: L3 11.15.24 MLH
24-25: L3 5.28.24 MLH

*owner said AGF was to be torn down
has not happened update inventory close tag*

*2026
Input MLH
2/26/26*

Notations

RP/MS	Code	Description
RP	ZONED	FARM EFU ZONED

Farm livestock

OSDs

Count	Code	Description	RMV	Code Area	Exception
1	SAA	SA OSD - AVERAGE	50000	04500	0

Land

Site: 2 Code Area: 04500 Size: 1.00 Acres Use Code: 005 Zone: REST SAV Use: 011 Exception: 0
 Class: 2BD Value Source: Farm Homesite Description: TWO BENCH DRY RMV: 41220 Exception: Y N
 Adjustment(s): GSOIL Fire Patrol: Description:
 Comments: Liability year - 2009

25-26: Updated land

Site: 3 Code Area: 04500 Size: 6.90 Acres Use Code: 005 Zone: REST SAV Use: 011 Exception: 0
 Class: 2BD Value Source: Farm Use - EFU Description: TWO BENCH DRY RMV: 284430 Exception: Y N
 Adjustment(s): GSOIL Fire Patrol: Description:
 Comments: Liability year - 1974

Site: 4 Code Area: 04500 Size: 2.00 Acres Use Code: 005 Zone: REST SAV Use: 011 Exception: 0
 Class: 2BD Value Source: Woodlot Description: TWO BENCH DRY RMV: 82450 Exception: Y N
 Adjustment(s): GSOIL Fire Patrol: Description:
 Comments: Liability year - 1974

Improvements - Residence / Manufactured Structures

Bldg: 1 Code Area: 04500 Stat Class: 131 Year Blt: 1949 Eff Year Blt: 1960 Sq.Ft: 1761 % Complete: 100.00
 Desc: One Story Only Dimensions: RMV: 266470
 Func Obsc: 100 Econ %: 100 Other %: 100 Exception: 0 Adjust: Adjust RMV: 0

I/O

Floors

Type	Class	Display Group	Floor Size	Beds	Baths	Yr Blt	Eff Yr Blt	Inventory	Exception
First Floor	3	Finished	472	0	0	1949	1960	ROOF, HVAC	Y N
First Floor	3	Finished	1289	2	FB-1	1949	1960	ROOF, FP - 1, HVAC+, KIT, BATH - 1	Y N
Garage Attached	3	Finished	960	1	HB-1	1949	1960	ROOF, BTH - 1	Y N

Accessories

Change to DGOE and break out

Description	Class	Size SqFt	Eff Yr Blt	RMV	Quantity
YARD IMPROVEMENTS AVERAGE	3	1	1960	13482	1

Improvements - Accessory Buildings

Bldg: 2 Code Area: 04500 Stat Class: 312 Year Blt: 1984 Eff Year Blt: 1984 Sq.Ft: 1680 % Complete: 100.00
 Desc: Loft Barn (LB) Dimensions: 56x30 RMV: 10990
 Func Obsc: 100 Econ %: 100 Other %: 100 Exception: 0 Adjust: Adjust RMV: 0

N/C

Floors

Type	Class	Display Group	Floor Size	Beds	Baths	Yr Blt	Eff Yr Blt	Inventory	Exception
Loft Barn	5	Finished	1680	0	0	1984	1984	FAIR	Y N

Accessories

Description	Class	Size SqFt	Eff Yr Blt	RMV	Quantity
No accessory data available					

Bldg: 3 Code Area: 04500 Stat Class: 355 Year Blt: 1984 Eff Year Blt: 1984 Sq.Ft: 600 % Complete: 100.00
 Desc: Lean-to Heavy (LTH) GB Dimensions: 30x20 RMV: 810
 Func Obsc: 100 Econ %: 100 Other %: 100 Exception: 0 Adjust: Adjust RMV: 0

I/O

Floors

Type	Class	Display Group	Floor Size	Beds	Baths	Yr Blt	Eff Yr Blt	Inventory	Exception: Y N
Lean-to Heavy Duty	4	Finished	600	0	0	1984	1984	Fair	

Accessories

Description	Class	Size SqFt	Eff Yr Blt	RMV	Quantity
No accessory data available					

Bldg: 4 Code Area: 04500 Stat Class: 341 Year Blt: 1984 Eff Year Blt: 1984 Sq.Ft: 216 % Complete: 100.00
 Desc: Multi Purpose Shed (MP) Dimensions: RMV: 1130
 Func Obsc: 100 Econ %: 100 Other %: 100 Exception: 0 Adjust: Adjust RMV: 0

W/C

Floors

Type	Class	Display Group	Floor Size	Beds	Baths	Yr Blt	Eff Yr Blt	Inventory	Exception: Y N
Multi-Purpose Bldg	5	Finished	216	0	0	1984	1984	FAIR	

Accessories

Description	Class	Size SqFt	Eff Yr Blt	RMV	Quantity
No accessory data available					

Bldg: 5 Code Area: 04500 Stat Class: 351 Year Blt: 2024 Eff Year Blt: 2024 Sq.Ft: 1800 % Complete: 100.00
 Desc: General Purpose Building (GB) Dimensions: 60x30 RMV: 43520
 Func Obsc: 100 Econ %: 100 Other %: 100 Exception: 20760 Adjust: Adjust RMV: 0

W/C

Floors

Type	Class	Display Group	Floor Size	Beds	Baths	Yr Blt	Eff Yr Blt	Inventory	Exception: Y N
General Purpose Bldg	5	Finished	1800	0	HB-1	2024	2024	AVG, BTH - 1	

Accessories

Description	Class	Size SqFt	Eff Yr Blt	RMV	Quantity
No accessory data available					

Farm Notes

2023FARM

1/9/23: New owner letter sent, no response. Check farm use 5/1/24./cwo

2024FARM

5/28/24: Per MLH property is gated. Aerials look like seed. Confirm during tag in 2025-26

2025FARM

11/15/24: Inspected by MLH L3 farm use ok - seed, livestock

355 LT/H 12x26 1984 I/O

SKETCH/AREA TABLE ADDENDUM

SUBJECT INFO

File No.: 521115 Parcel No.: 071W05 01500
 Property Address: 10833 Selah Springs Rd NE
 City: Silverton County: State: OR ZipCode: 97381
 Owner:
 Client: Client Address:
 Appraiser Name: Inspection Date:

SKETCH

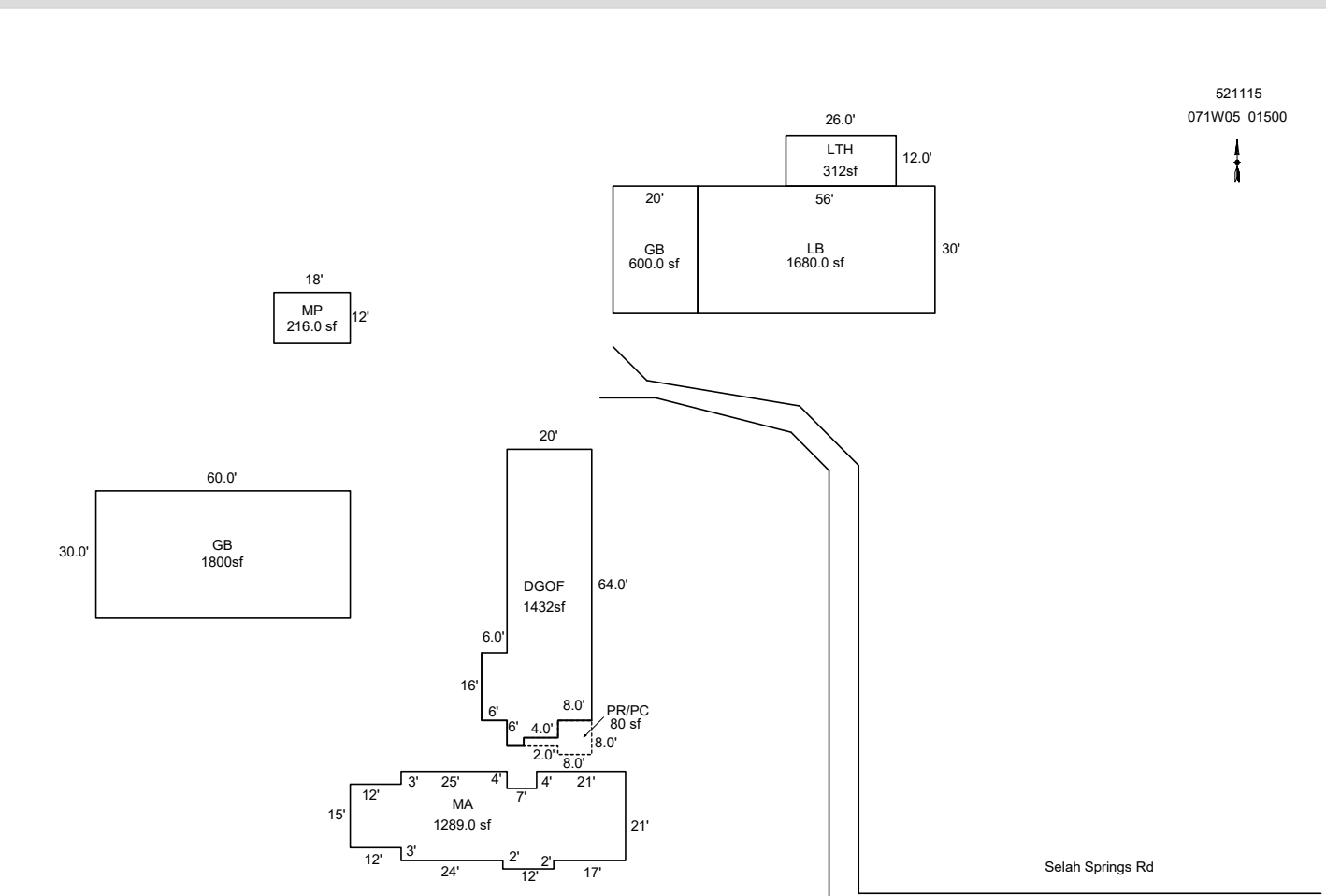

Sketch by ApexSketch

AREA CALCULATIONS SUMMARY						COMMENT TABLE 1			
Code	Description	Factor	Net Size	Perimeter	Net Totals				
GBA1	LB	1.0	1680.0	172.0		05/06/13 Jane UPDATED BY CLOBERG 03/14/25 UPDATED BY CLOBERG 03/10/26			
	GB	1.0	600.0	100.0					
	MP	1.0	216.0	60.0					
GLA1	GB	1.0	1800.0	180.0	4296.0				
	MA	1.0	1289.0	184.0					
GAR	MA	1.0	0.0	54.0	1289.0				
	DGOF	1.0	1432.0	192.0	1432.0				
LTH	LTH	1.0	312.0	76.0	312.0				
PR/PC	PR/PC	1.0	79.9	48.0	79.9				
						COMMENT TABLE 2	COMMENT TABLE 3		
						MLH 11/15/24 MLH 02/26/26	TAGS L3 TAGS L4		
Net LIVABLE		cnt	2	(rounded)	3,033				
Net BUILDING		cnt	0	(rounded)	4,296				

SKETCH/AREA TABLE ADDENDUM

SUBJECT INFO

File No.: 521115 Parcel No.: 071W05 01500
 Property Address: 10833 Selah Springs Rd NE
 City: Silverton County: State: OR ZipCode: 97381
 Owner:
 Client: Client Address:
 Appraiser Name: Inspection Date:

SKETCH

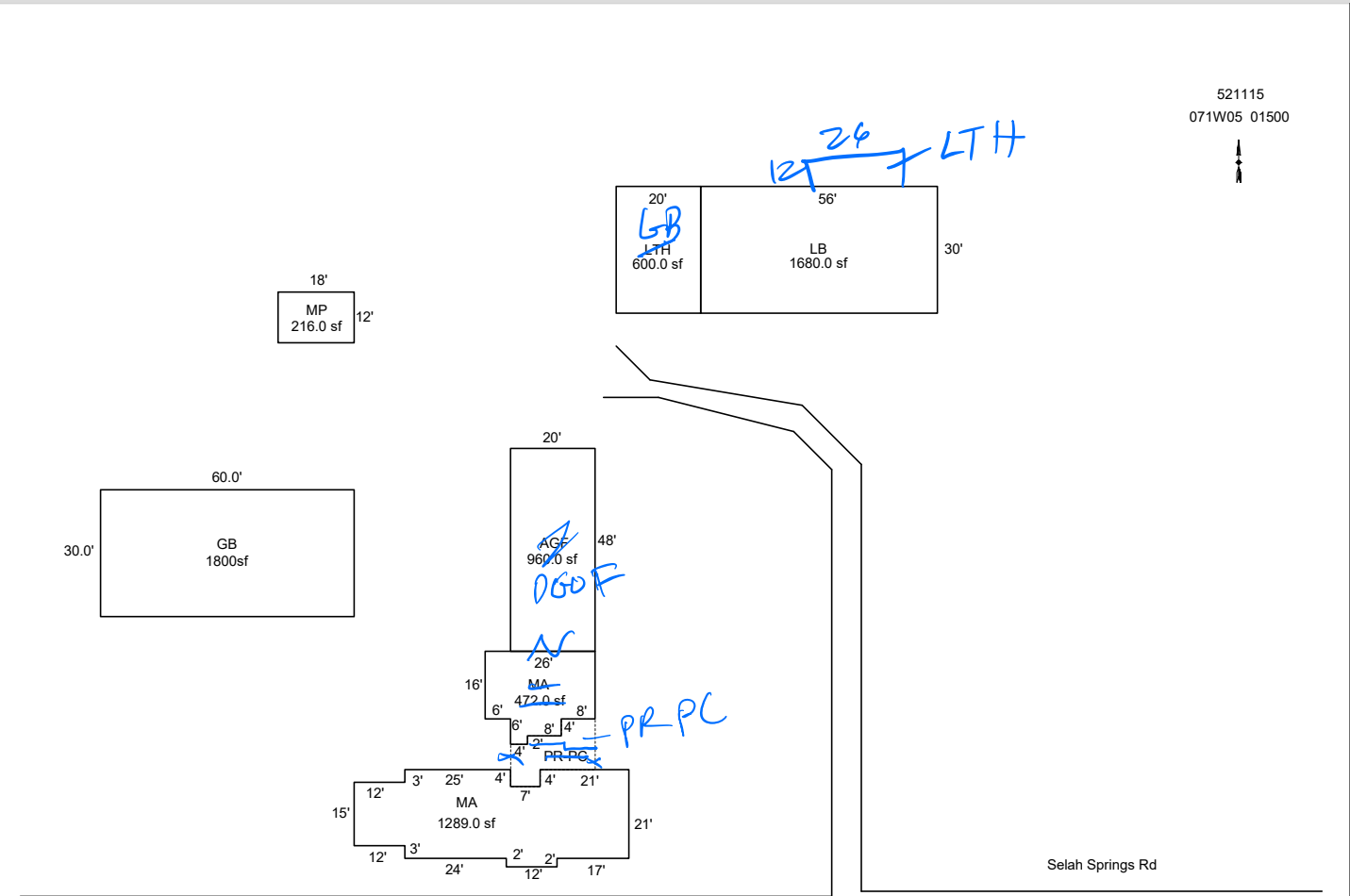

Sketch by ApexSketch

AREA CALCULATIONS SUMMARY

Code	Description	Factor	Net Size	Perimeter	Net Totals
GBA1	LB	1.0	1680.0	172.0	
	LTH	1.0	600.0	100.0	
	MP	1.0	216.0	60.0	
	GB	1.0	1800.0	180.0	4296.0
GLA1	MA	1.0	1289.0	184.0	
	MA	1.0	472.0	96.0	1761.0
GAR	AGF	1.0	960.0	136.0	960.0
P/P	PR-PC	1.0	212.0	72.0	212.0
	Net LIVABLE	cnt	0 (rounded)		1,761
	Net BUILDING	cnt	4 (rounded)		4,296

COMMENT TABLE 1

05/06/13 Jane
 UPDATED BY CLOBERG 03/14/25

COMMENT TABLE 2

MLH 11/15/24

MLH 2/26/26

COMMENT TABLE 3

TAGS L3

Tags 24