

Summary

Lead Appr: MLH Clerk: \_\_\_\_\_ Lead Clerk: \_\_\_\_\_ Appr: MLH 3/5/26

Print Date: 12/26/2025

Acct ID: 520732 MTL: 071W02C001400 Date: 2/27/26 Appr: MLH Prop Class: 401 RMV Prop Class: 401  
Situs: 4269 VICTOR POINT RD NE SILVERTON OR 97381 MaSaNh: 03 06 000 Unit: 50570 Year: 2026

Last Date Appraised: 01/10/2024 Appraiser: MATTHEW HAMILTON Tag: Y N Tag info: 2024 - Tags/Permit (Addition)

Owner: NELSON, BROCK Last Sales Date: 10/13/2025 Roll Type: R

Cycle Tag Sales Verification Other: \_\_\_\_\_ Inspection level: 1 2 3 4 LCB TTO INSP AV: 494710

RMV Land: 393360 RMV Imp: 473710 RMV Total: 867070 MAV: 494710 MSAV: 0 SAV: 0

Comment: 24-25: L3 1.10.24 MLH

*MLS 829683  
DOM 133  
Sales Code 33*

*update Inventory*

*Input MLH  
2/27/26*

OSDs

Count	Code	Description	RMV	Code Area	Exception
1	MKTA	OSD - AVERAGE	55000	04500	0
1	MKTN	OSD - NO LANDSCAPE	40000	04500	0

Land

Site: 2 Code Area: 04500 Size: 1.50 Acres Use Code: 004 Zone: NREST SAV Use: Exception: 0  
 Class: 6B Value Source: Rural at MKT Description: SIX BENCH RMV: 108320 Exception: Y N  
 Adjustment(s): FSOIL Fire Patrol: Description:  
 Comments: 14-15: PER #31 ADD TREED ADJ

Site: 4 Code Area: 04500 Size: 2.50 Acres Use Code: 004 Zone: NREST SAV Use: Exception: 0  
 Class: 4B8D Value Source: Rural at MKT Description: FOUR BENCH DRY RMV: 190040 Exception: Y N  
 Adjustment(s): FSOIL Fire Patrol: Description:  
 Comments:

*EVB Roof paint  
1989 Door counter*

Improvements - Residence / Manufactured Structures

Bldg: 1 Code Area: 04500 Stat Class: 142 + Year Blt: 1972 Eff Year Blt: 1985 Sq.Ft: 3010 % Complete: 100.00  
 Desc: Multi Story above grade Dimensions: RMV: 368930  
 Func Obsc: 100 Econ %: 100 Other %: 100 Exception: 0 Adjust: Adjust RMV: 0 *I/O*

Floors

Type	Class	Display Group	Floor Size	Beds	Baths	Yr Blt	Eff Yr Blt	Inventory	Exception
First Floor	4 +	Finished	2238	1	FB-2/ HB-1	1972	1985	ROOF, FP - 2, KIT, BTH - 1, BATH - 2, HVAC <i>+ bath +</i>	Y N
Attic	4 +	Finished	772	<i>3</i>	<i>1</i>	1972	1985	HVAC <i>+</i>	Y N
Garage Attached	4	Low Cost	576	0	0	1972	1985	ROOF	Y N

Accessories

Description	Class	Size SqFt	Eff Yr Blt	RMV	Quantity
No accessory data available <i>VI 4 A</i>					

Bldg: 4 Code Area: 04500 Stat Class: 121 Year Blt: 1972 Eff Year Blt: 1985 Sq.Ft: 520 % Complete: 100.00  
 Desc: One Story Only Dimensions: RMV: 49450  
 Func Obsc: 100 Econ %: 100 Other %: 100 Exception: 0 Adjust: Adjust RMV: 0 *I/O*

Floors

Type	Class	Display Group	Floor Size	Beds	Baths	Yr Blt	Eff Yr Blt	Inventory	Exception
First Floor	2	Finished	520	1	FB-1	1972	1985	KIT-, HVAC, ROOF, BATH - 1	Y N

Accessories

Description	Class	Size SqFt	Eff Yr Blt	RMV	Quantity
No accessory data available <i>VI 2A</i>					

Bldg: 5 Code Area: 04500 Stat Class: 107 Year Blt: Eff Year Blt: 1985 Sq.Ft: 0 % Complete: 100.00  
 Desc: Yard Improvements Dimensions: RMV: 29920  
 Func Obsc: 100 Econ %: 100 Other %: 100 Exception: ~~0~~ Adjust: Adjust RMV: 0

Floors

Type	Class	Display Group	Floor Size	Beds	Baths	Yr Blt	Eff Yr Blt	Inventory	Exception
No floor data available									

Accessories

Description	Class	Size SqFt	Eff Yr Blt	RMV	Quantity
YARD IMPROVEMENTS AVERAGE	5	1	1985	29920	1

*Combine segs make MAU*

Improvements - Accessory Buildings

Bldg: 3 Code Area: 04500 Stat Class: 353 Year Blt: 1994 Eff Year Blt: 1998 Sq.Ft: 1440 % Complete: 100.00  
 Desc: Machine Shed (MS) Dimensions: 60x24 RMV: 11240

Func Obsc: 100 Econ %: 100 Other %: 100 Exception: 0 Adjust: Adjust RMV: 0

N/C

Floors

Type	Class	Display Group	Floor Size	Beds	Baths	Yr Blt	Eff Yr Blt	Inventory	Exception: Y N
Machine Shed	5	Finished	1440	0	0	1994	1998	FAIR	

Accessories

Description	Class	Size SqFt	Eff Yr Blt	RMV	Quantity
No accessory data available					

Bldg: 6 Code Area: 04500 Stat Class: 341 Year Blt: 2016 Eff Year Blt: 2016 Sq.Ft: 192 % Complete: 100.00  
 Desc: Multi Purpose Shed (MP) Dimensions: 16x12 RMV: 4730  
 Func Obsc: 100 Econ %: 100 Other %: 100 Exception: 0 Adjust: Adjust RMV: 0

N/C

Floors

Type	Class	Display Group	Floor Size	Beds	Baths	Yr Blt	Eff Yr Blt	Inventory	Exception: Y N
Multi-Purpose Bldg	5	Finished	192	0	0	2016	2016	FAIR	

Accessories

Description	Class	Size SqFt	Eff Yr Blt	RMV	Quantity
No accessory data available					

Bldg: 7 Code Area: 04500 Stat Class: 357 Year Blt: 2014 Eff Year Blt: 2014 Sq.Ft: 400 % Complete: 100.00  
 Desc: Frost Control Dimensions: 20x20 RMV: 1000  
 Func Obsc: 100 Econ %: 100 Other %: 100 Exception: 0 Adjust: Adjust RMV: 0

N/C

Floors

Type	Class	Display Group	Floor Size	Beds	Baths	Yr Blt	Eff Yr Blt	Inventory	Exception: Y N
Frost Control	4	Finished	400	0	0	2014	2014		

Accessories

Description	Class	Size SqFt	Eff Yr Blt	RMV	Quantity
No accessory data available					

Bldg: 8 Code Area: 04500 Stat Class: 354 Year Blt: 2014 Eff Year Blt: 2014 Sq.Ft: 192 % Complete: 100.00  
 Desc: Lean-to Light (LTL) Dimensions: 16x12 RMV: 670  
 Func Obsc: 100 Econ %: 100 Other %: 100 Exception: 0 Adjust: Adjust RMV: 0

N/C

Floors

Type	Class	Display Group	Floor Size	Beds	Baths	Yr Blt	Eff Yr Blt	Inventory	Exception: Y N
Lean-to Light Duty	4	Finished	192	0	0	2014	2014		

Accessories

Description	Class	Size SqFt	Eff Yr Blt	RMV	Quantity
No accessory data available					

Bldg: 9 Code Area: 04500 Stat Class: 341 Year Blt: 1994 Eff Year Blt: 1998 Sq.Ft: 480 % Complete: 100.00  
 Desc: Multi Purpose Shed (MP) Dimensions: RMV: 6440  
 Func Obsc: 100 Econ %: 100 Other %: 100 Exception: 0 Adjust: Adjust RMV: 0

N/C

Floors

Type	Class	Display Group	Floor Size	Beds	Baths	Yr Blt	Eff Yr Blt	Inventory	Exception: Y N
Multi-Purpose Bldg	5	Finished	480	0	0	1994	1998	AVG	

Accessories

Description	Class	Size SqFt	Eff Yr Blt	RMV	Quantity
No accessory data available					

Bldg: 10 Code Area: 04500 Stat Class: 355 Year Blt: Eff Year Blt: 1998 Sq.Ft: 96 % Complete: 100.00  
 Desc: Lean-to Heavy (LTH) Dimensions: RMV: 330  
 Func Obsc: 100 Econ %: 100 Other %: 100 Exception: 0 Adjust: Adjust RMV: 0

N/C

Floors

Type	Class	Display Group	Floor Size	Beds	Baths	Yr Blt	Eff Yr Blt	Inventory	Exception: Y N
Lean-to Heavy Duty	5	Finished	96	0	0	0	1998		

Accessories

Description	Class	Size SqFt	Eff Yr Blt	RMV	Quantity
No accessory data available					

Bldg: 11 Code Area: 04500 Stat Class: 357 Year Blt: 2014 Eff Year Blt: 2014 Sq.Ft: 400 % Complete: 100.00  
 Desc: Frost Control Dimensions: RMV: 1000  
 Func Obsc: 100 Econ %: 100 Other %: 100 Exception: 0 Adjust: Adjust RMV: 0

N/C

Floors

Type	Class	Display Group	Floor Size	Beds	Baths	Yr Blt	Eff Yr Blt	Inventory
Frost Control	4	Finished	400	0	0	2014	2014	Exception: Y N

**Accessories**

Description	Class	Size SqFt	Eff Yr Blt	RMV	Quantity
No accessory data available					

357 FL 5 2010 10x16 Exempt

# SKETCH/AREA TABLE ADDENDUM

## SUBJECT INFO

File No.: 520732 Parcel No.: 071W02C 01400  
 Property Address: 4269 VICTOR POINT RD NE  
 City: SILVERTON County: MARION State: OR ZipCode: 97381  
 Owner:  
 Client Address:  
 Appraiser Name: Inspection Date:

## SKETCH

**520732**  
**071W02C 01400**  
 SCALE = 1:50

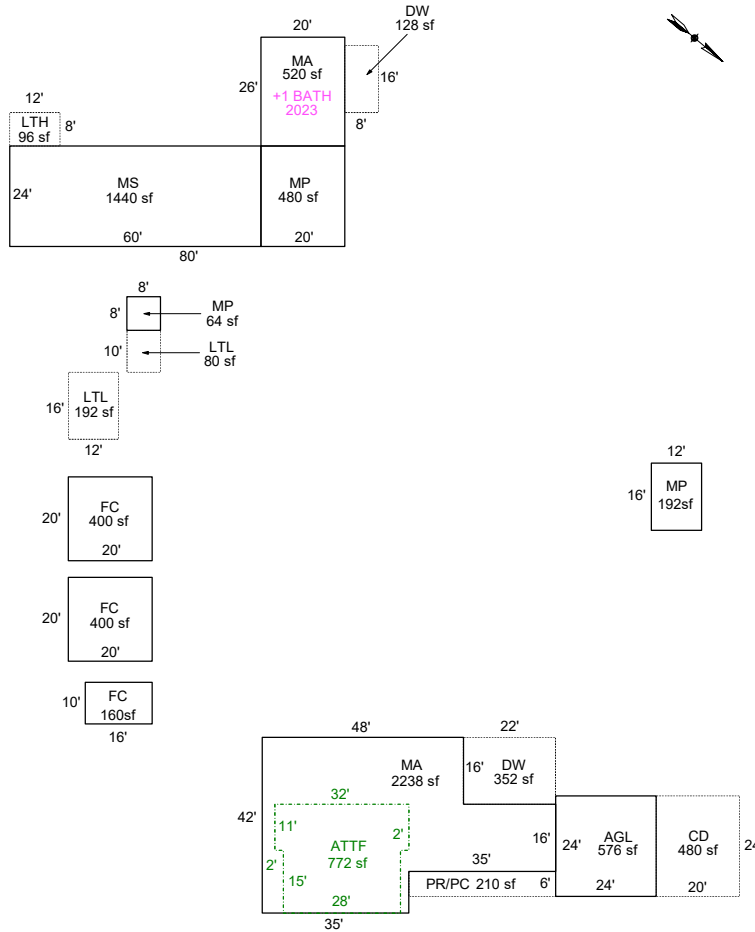

Sketch by ApexSketch

AREA CALCULATIONS SUMMARY						COMMENT TABLE 1	
Code	Description	Factor	Net Size	Perimeter	Net Totals		
GBA1	MS	1.0	1440.0	168.0		DRAWN BY PT 5/03/2011 Updated to add LTL and DW 3/5/13 Jane UPDATED BY JRONDEMA 2/13/19 UPDATED BY CJURAN 09/25/2023 23-006433 AD UPDATED BY CJURAN 01/31/2024 UPDATED BY CLOBERG 03/06/26	
	MP	1.0	480.0	88.0			
	LTH	1.0	96.0	40.0			
	LTL	1.0	80.0	36.0			
	MP	1.0	192.0	56.0			
	MP	1.0	64.0	32.0			
	FC	1.0	400.0	80.0			
	FC	1.0	400.0	80.0			
	LTL	1.0	192.0	56.0	3344.0		
	GLA1	MA	1.0	2238.0	224.0		
GLA1	MA	1.0	520.0	92.0	2758.0		
GLA2	ATTF	1.0	772.0	116.0	772.0	MLH 01/10/2024	TAGS L3
FC	FC	1.0	160.0	52.0	160.0	MLH 02/27/26	SV L4
P/P	DW	1.0	352.0	76.0			
	PR/PC	1.0	210.0	82.0			
	CD	1.0	480.0	88.0			
	1 addl items						
	Net LIVABLE	cnt	1	(rounded)		3,690	
Net BUILDING	cnt	0	(rounded)		3,344		

# SKETCH/AREA TABLE ADDENDUM

## SUBJECT INFO

File No.: 520732 Parcel No.: 071W02C 01400  
 Property Address: 4269 VICTOR POINT RD NE  
 City: SILVERTON County: MARION State: OR ZipCode: 97381  
 Owner:  
 Client: Client Address:  
 Appraiser Name: Inspection Date:

## SKETCH

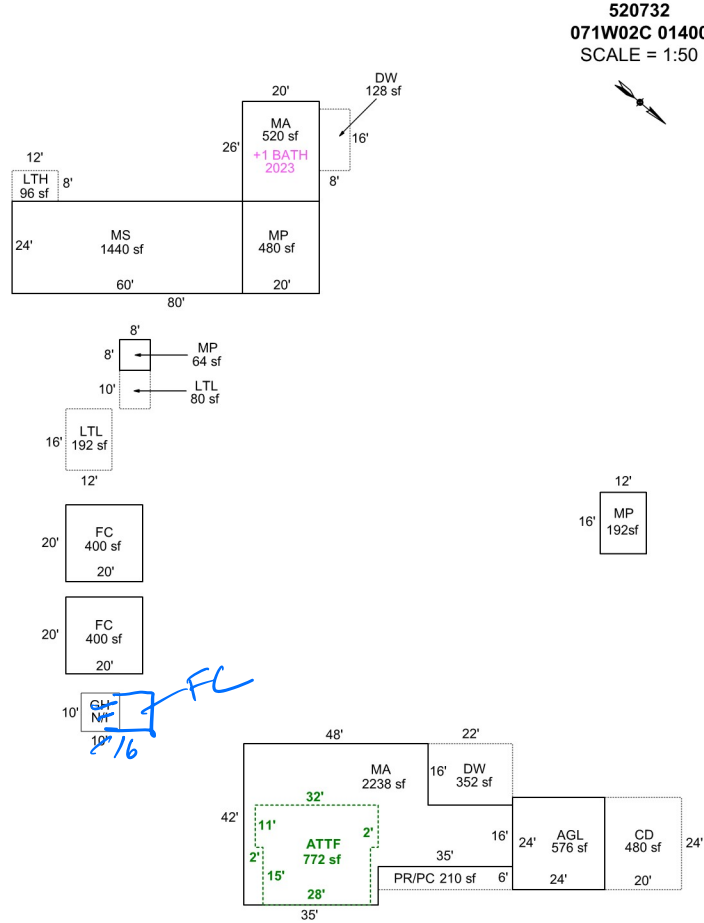

Sketch by Apex Sketch

### AREA CALCULATIONS SUMMARY

Code	Description	Factor	Net Size	Perimeter	Net Totals
GBA1	MS	1.0	1440.0	168.0	
	MP	1.0	480.0	88.0	
	LTH	1.0	96.0	40.0	
	LTL	1.0	80.0	36.0	
	MP	1.0	192.0	56.0	
	MP	1.0	64.0	32.0	
	FC	1.0	400.0	80.0	
	FC	1.0	400.0	80.0	
	LTL	1.0	192.0	56.0	3344.0
	GLA1	MA	1.0	2238.0	224.0
	MA	1.0	520.0	92.0	2758.0
GLA2	ATTF	1.0	772.0	116.0	772.0
P/P	DW	1.0	352.0	76.0	
	PR/PC	1.0	210.0	82.0	
	CD	1.0	480.0	88.0	
	DW	1.0	128.0	48.0	1170.0
	Net LIVABLE	cnt	3	(rounded)	3,530
	Net BUILDING	cnt	9	(rounded)	3,344

### COMMENT TABLE 1

DRAWN BY PT 5/03/2011  
 Updated to add LTL and DW 3/5/13 Jane  
 UPDATED BY JRONDEMA 2/13/19  
 UPDATED BY CJURAN 09/25/2023 23-006433 AD  
 UPDATED BY CJURAN 01/31/2024

### COMMENT TABLE 2

MLH 01/10/2024

### COMMENT TABLE 3

TAGS L3