

Acct ID: 518999 MTL: 062W24D000800 Date: 10/2/25 Appr: MLH Prop Class: 551 RMV Prop Class: 451
 Situs: 9472 NUSOM RD NE SILVERTON OR 97381 MaSaNh: 03 06 000 Unit: 54459 Year: 2025

2026

Last Date Appraised: 04/19/2011 Appraiser: MATTHEW HAMILTON Tag: Y N Tag info:
 Owner: GOULD, JULIA Last Sales Date: 08/14/2025 Roll Type: R
 Cycle Tag Sales Verification Other: _____ Inspection level: 1 2 3 4 LCB TTO INSP AV: 155758
 RMV Land: 350710 RMV Imp: 236230 RMV Total: 586940 MAV: 99590 MSAV: 56168 SAV: 120063

Comment: MLS 831029
DOM 43

Notations Sales Code Estate Sale update Inventory input MLH 11/6/25

RP/MS	Code	Description
RP	ZONED	FARM EFU ZONED

OSDs

Count	Code	Description	RMV	Code Area	Exception
1	SAA	SA OSD - AVERAGE	50000	01470	0

Land

Site: 2	Code Area: 01470	Size: 1.00 Acres	Use Code: 005	Zone: REST	SAV Use: 011	Exception: 0
Class: <u>2BD</u>	Value Source: Farm Homesite	Description:			RMV: 97580	Exception: Y N
Adjustment(s):	GSOIL, IRR	Fire Patrol:		Description:		
Comments: Liability year - 2009 / 100150						
Site: 3	Code Area: 01470	Size: 1.81 Acres	Use Code: 005	Zone: REST	SAV Use: 011	Exception: 0
Class: <u>2BD</u>	Value Source: Farm Use - EFU	Description: TWO BENCH IRR			RMV: 203130	Exception: Y N
Adjustment(s):	GSOIL, IRR	Fire Patrol:		Description:		
Comments: Liability year - 1984 / 100150						

Improvements - Residence / Manufactured Structures

Bldg: 1	Code Area: 01470	Stat Class: 132	Year Blt: 1936	Eff Year Blt: 1963	Sq.Ft: 1640	% Complete: 100.00
Desc: Multi Story above grade			Dimensions:		RMV: 177110	
Func Obsc: 100	Econ %: 100	Other %: 100	Exception: 0	Adjust:	Adjust RMV: 0	<u>N/C</u>

Floors

Type	Class	Display Group	Floor Size	Beds	Baths	Yr Blt	Eff Yr Blt	Inventory	Exception
First Floor	3	Finished	1100	1	FB-2	1936	1963	HVAC+, ROOF, KIT, BATH - 2	Y N
Attic	3	Finished	540	1	0	1936	1963	HVAC+	Y N

Accessories

Description	Class	Size SqFt	Eff Yr Blt	RMV	Quantity	Exception
ENCLOSED PORCH	3	36	1963	767	1	Y N
YARD IMPROVEMENTS AVERAGE	3	1	1963	13675	1	Y N

Bldg: 2	Code Area: 01470	Stat Class: 138	Year Blt: 1969	Eff Year Blt: 1969	Sq.Ft: 0	% Complete: 100.00
Desc: Res other improvements			Dimensions:		RMV: 50950	
Func Obsc: 100	Econ %: 100	Other %: 100	Exception: 0	Adjust:	Adjust RMV: 0	<u>±/0</u>

Floors

Type	Class	Display Group	Floor Size	Beds	Baths	Yr Blt	Eff Yr Blt	Inventory	Exception
Garage Detached	3	Finished	800	0	0	1969	1969	ROOF	Y N

Accessories

Description	Class	Size SqFt	Eff Yr Blt	RMV	Quantity
No accessory data available					

Improvements - Accessory Buildings

Bldg: 3	Code Area: 01470	Stat Class: 353	Year Blt: 1987	Eff Year Blt: 1987	Sq.Ft: 1200	% Complete: 100.00
Desc: Machine Shed (MS)			Dimensions: 60x20		RMV: 4380	
Func Obsc: 100	Econ %: 100	Other %: 100	Exception: 0	Adjust:	Adjust RMV: 0	<u>I/O</u>

Floors

Type	Class	Display Group	Floor Size	Beds	Baths	Yr Blt	Eff Yr Blt	Inventory	Exception
Machine Shed	5	Finished	1200	0	0	1987	1987	<u>Fai</u>	Y N

Accessories

Description	Class	Size SqFt	Eff Yr Blt	RMV	Quantity
No accessory data available					

Bldg: 4 Code Area: 01470 Stat Class: 341 Year Blt: 1993 Eff Year Blt: 1993²⁰⁰⁰ Sq.Ft: 224 % Complete: 100.00

Desc: Multi Purpose Shed (MP)

Dimensions: 16x14

RMV: 3790

Func Obsc: 100

Econ %: 100

Other %: 100

Exception: 0

Adjust:

Adjust RMV: 0

I/O

Floors

Type	Class	Display Group	Floor Size	Beds	Baths	Yr Blt	Eff Yr Blt	Inventory	Exception: Y N
Multi-Purpose Bldg	6	Finished	224	0	0	1993	1993	FAIR <i>Good</i>	

Accessories

Description	Class	Size SqFt	Eff Yr Blt	RMV	Quantity
No accessory data available					

SKETCH/AREA TABLE ADDENDUM

SUBJECT INFO

File No.: 518999 Parcel No.: 062W24D 00800
 Property Address: 9472 NUSOM RD NE
 City: SILVERTON County: State: OR ZipCode: 97381
 Owner:
 Client: Client Address:
 Appraiser Name: Inspection Date:

SKETCH

518999
062W24D 00800

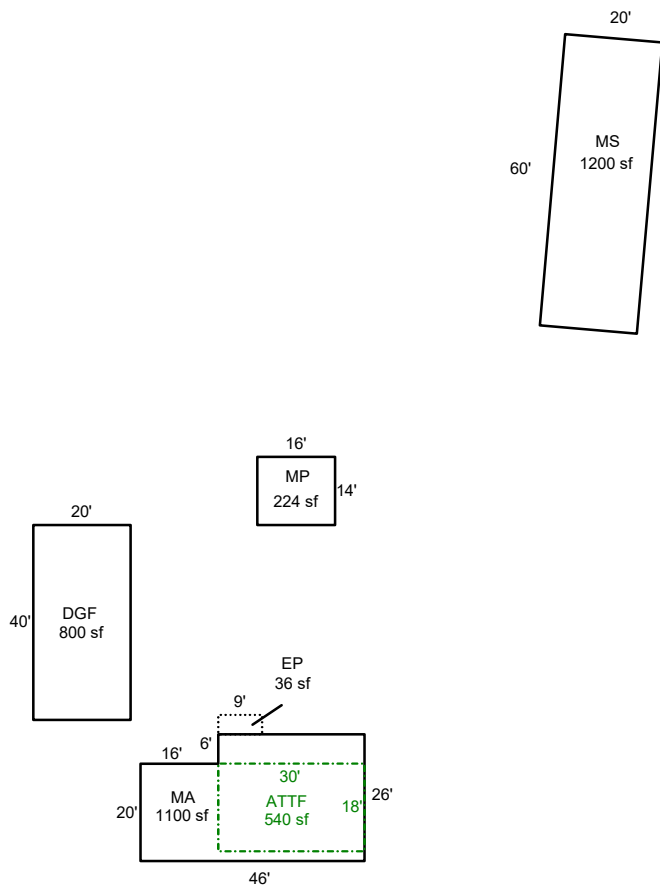

Sketch by ApexSketch

AREA CALCULATIONS SUMMARY						COMMENT TABLE 1	
Code	Description	Factor	Net Size	Perimeter	Net Totals		
GBA1	MP	1.0	224.0	60.0		DRAWN BY 12/08/2008 Chg PR to EP - CE 5/19/11 UPDATED BY CLOBERG 12/30/25	
	MS	1.0	1200.0	160.0	1424.0		
GLA1	MA	1.0	1100.0	144.0	1100.0		
GLA2	ATTF	1.0	540.0	96.0	540.0		
GAR	DGF	1.0	800.0	120.0	800.0		
P/P	EP	1.0	36.0	26.0	36.0		
						COMMENT TABLE 2	COMMENT TABLE 3
						MLH 10/02/25	SV L4
		Net LIVABLE	cnt	1 (rounded)	2,440		
		Net BUILDING	cnt	0 (rounded)	1,424		

R18999
062W24D 00800

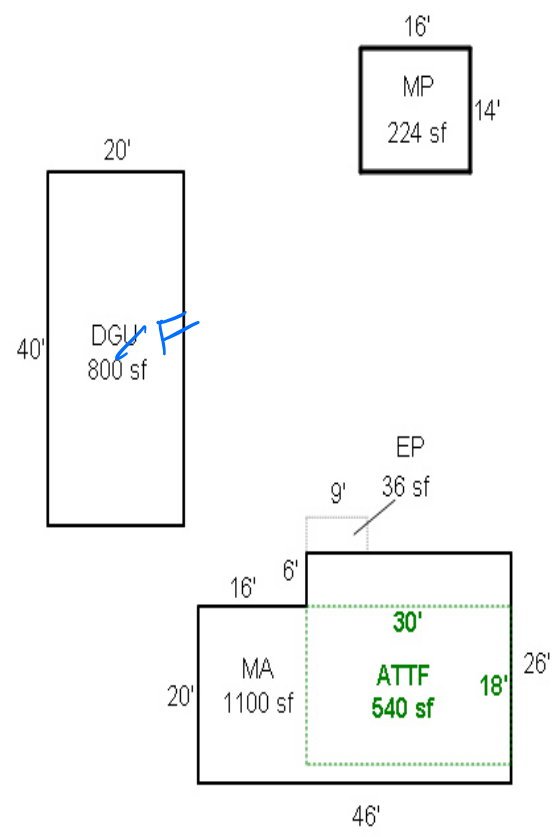
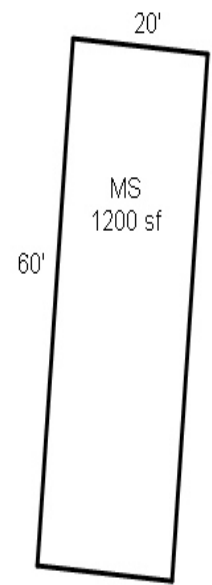

MUH 10/2/25 SV LY