

SKETCH/AREA TABLE ADDENDUM

SUBJECT INFO

File No.: 107969 Parcel No.: 051W07DC02400
 Property Address: 860 N 1ST ST
 City: WOODBURN County: Marion State: OR ZipCode: 97071
 Owner:
 Client: Client Address:
 Appraiser Name: Inspection Date:

SKETCH

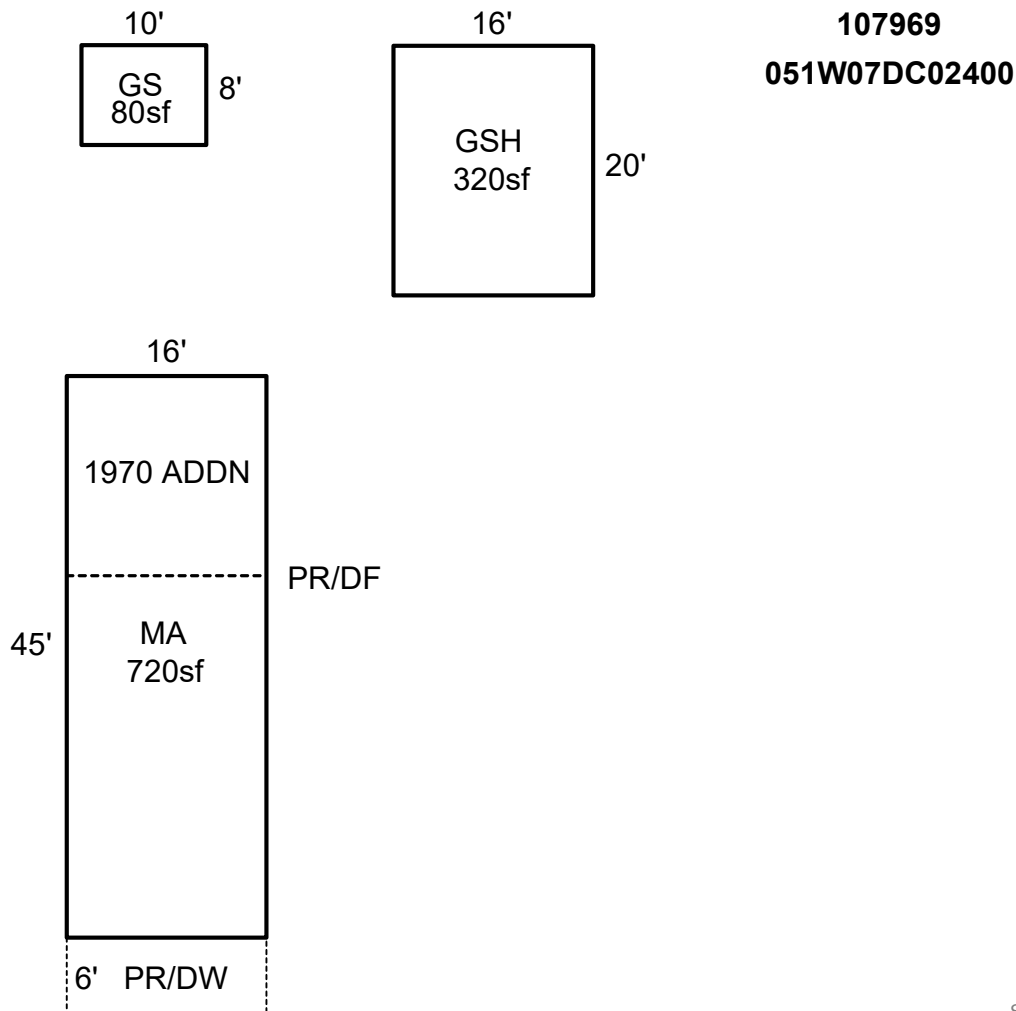

Sketch by ApexSketch

AREA CALCULATIONS SUMMARY

Code	Description	Factor	Net Size	Perimeter	Net Totals
GBA	GSH	1.0	320.0	72.0	
	GS	1.0	80.0	36.0	400.0
GLA	MA	1.0	720.0	122.0	720.0
	Net LIVABLE	cnt	1 (rounded)		720
	Net BUILDING	cnt	2 (rounded)		400

COMMENT TABLE 1

DRAWN BY PST 11/18/09
 UPDATED BY MONA 06.14.17
 Updated by AE 3.12.26

COMMENT TABLE 2

9-8-14 #42 Cycle NV
 6/1/17 #72 NV-Cycle
 9-18-23 #05 Cycle

COMMENT TABLE 3