

SKETCH/AREA TABLE ADDENDUM

SUBJECT INFO

File No.: 101503 Parcel No.: 061E22AB02000
 Property Address: 470 SCOTTS AV
 City: SCOTTS MILLS County: Marion State: OR ZipCode: 97375
 Owner:
 Client: Client Address:
 Appraiser Name: Inspection Date:

SKETCH

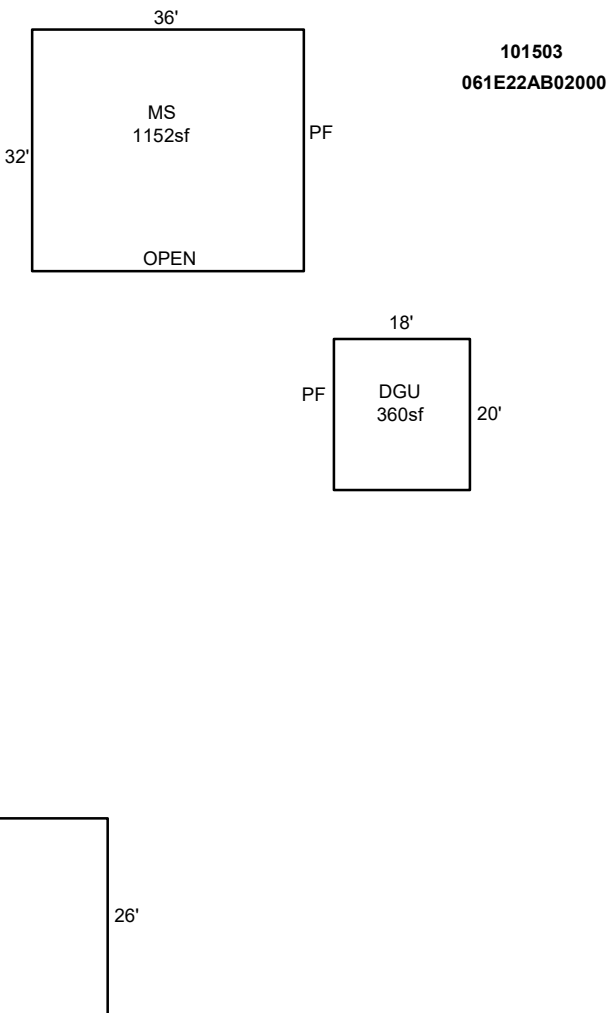

AREA CALCULATIONS SUMMARY

Code	Description	Factor	Net Size	Perimeter	Net Totals
GBA	MS	1.0	1152.0	136.0	
	GB	1.0	1092.0	136.0	2244.0
GAR	DGU	1.0	360.0	76.0	360.0
Net BUILDING		cnt	2 (rounded)		2,244

COMMENT TABLE 1

Drawn By: slong-01/14/2010
 Updated by AE 11.12.25
 UPDATED BY LK 3.11.26

COMMENT TABLE 2

9-1-17 96 Cycle NV
 6/7/19 #24 SV NV
 3.2.26 TAG AG

COMMENT TABLE 3