

SKETCH/AREA TABLE ADDENDUM

SUBJECT INFO

File No.: 105904 Parcel No.: 082W29DB05400
 Property Address: 7765 5TH ST SE
 City: TURNER County: State: OR ZipCode: 97392
 Owner:
 Client: Client Address:
 Appraiser Name: Inspection Date:

SKETCH

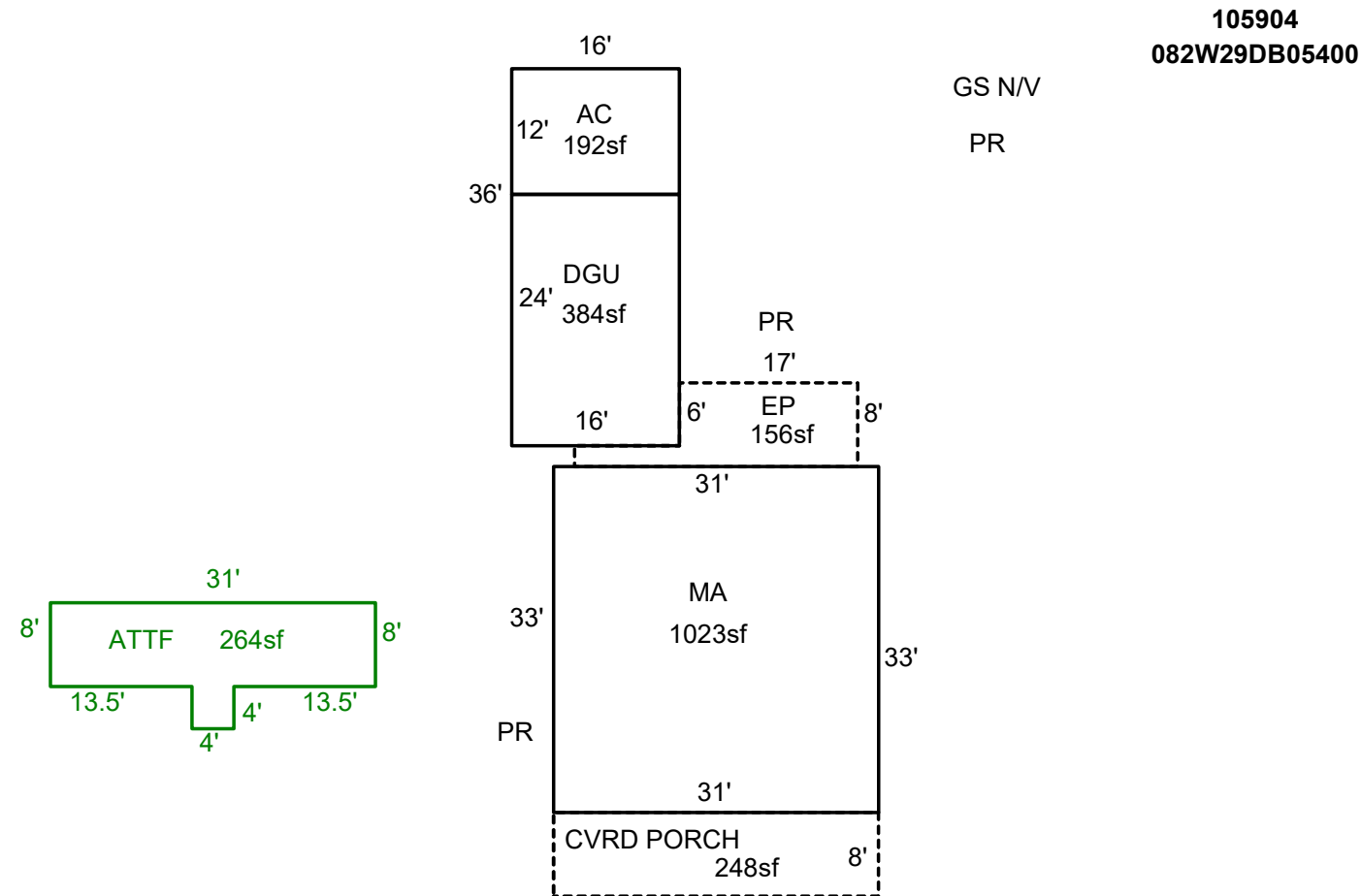

Sketch by ApexSketch

AREA CALCULATIONS SUMMARY						COMMENT TABLE 1	
Code	Description	Factor	Net Size	Perimeter	Net Totals		
GLA1	MA	1.0	1023.0	128.0	1023.0	DRAWN 11/02/10 by Tina UPDATED BY LK 3.6.26	
GLA2	ATTF	1.0	264.0	86.0	264.0		
GAR	DGU	1.0	384.0	80.0	576.0		
P/P	AC	1.0	192.0	56.0	70.0		
	EP	1.0	156.0	70.0	404.0		
	CVRD PORCH	1.0	248.0	78.0		COMMENT TABLE 2	COMMENT TABLE 3
						2.20.26	
	Net LIVABLE	cnt	0 (rounded)		1,287		