

# SKETCH/AREA TABLE ADDENDUM

## SUBJECT INFO

File No.: 105895 Parcel No.: 082W29DB04400  
 Property Address: 7645 5TH ST SE  
 City: TURNER County: State: OR ZipCode: 97392  
 Owner:  
 Client: Client Address:  
 Appraiser Name: Inspection Date:

## SKETCH

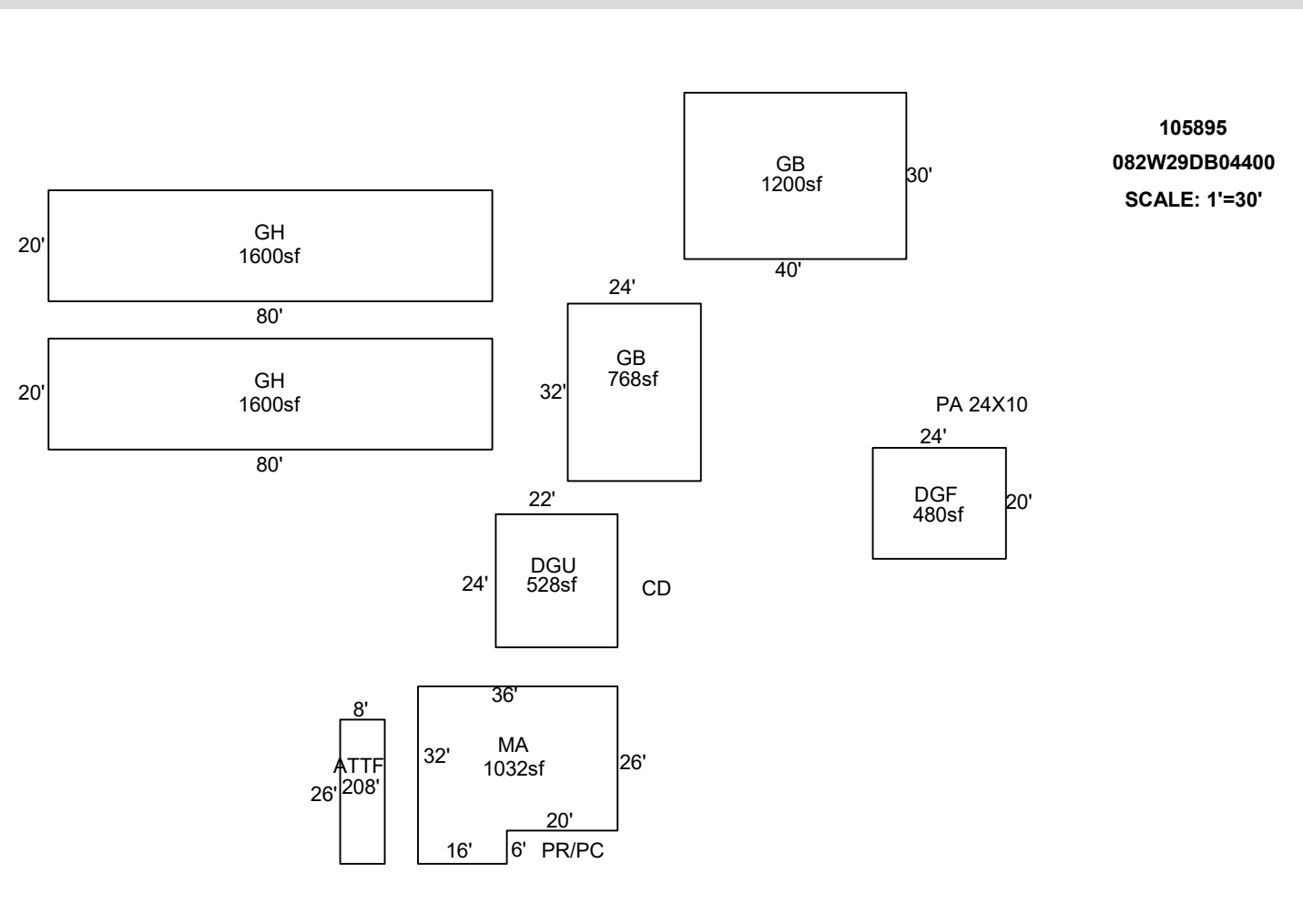

Sketch by ApexSketch

AREA CALCULATIONS SUMMARY						COMMENT TABLE 1					
Code	Description	Factor	Net Size	Perimeter	Net Totals						
GBA	GH	1.0	1600.0	200.0		DRAWN 11/01/10 by Tina UPDATED BY LK 3.6.26					
	GH	1.0	1600.0	200.0	3200.0						
GBA1	GB	1.0	768.0	112.0							
	GB	1.0	1200.0	140.0	1968.0						
GLA1	MA	1.0	1032.0	136.0	1032.0						
GLA2	ATTF	1.0	208.0	68.0	208.0						
DGF	DGF	1.0	480.0	88.0	480.0	<table border="1" style="width: 100%; border-collapse: collapse;"> <thead> <tr> <th style="text-align: center;">COMMENT TABLE 2</th> <th style="text-align: center;">COMMENT TABLE 3</th> </tr> </thead> <tbody> <tr> <td style="vertical-align: top;">2.20.26 CYCLE GM</td> <td></td> </tr> </tbody> </table>		COMMENT TABLE 2	COMMENT TABLE 3	2.20.26 CYCLE GM	
COMMENT TABLE 2	COMMENT TABLE 3										
2.20.26 CYCLE GM											
GARAGE	DGU	1.0	528.0	92.0	528.0						
	Net LIVABLE	cnt	0 (rounded)		1,240						
	Net BUILDING	cnt	2 (rounded)		5,168						