

SKETCH/AREA TABLE ADDENDUM

SUBJECT INFO

File No.: 105703 Parcel No.: 082W29DB03400
 Property Address: 7615 5TH ST SE
 City: TURNER County: State: OR ZipCode: 97392
 Owner:
 Client: Client Address:
 Appraiser Name: Inspection Date:

SKETCH

105703
082W29DB03400

N/V
GS 12X8

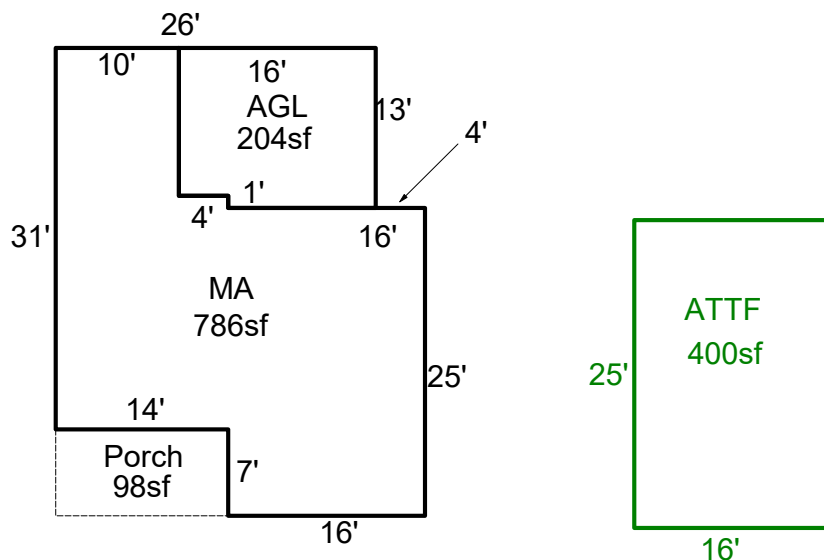

Sketch by ApexSketch

AREA CALCULATIONS SUMMARY

Code	Description	Factor	Net Size	Perimeter	Net Totals
GLA1	MA	1.0	786.0	136.0	786.0
GLA2	ATTF	1.0	400.0	82.0	400.0
GARAGE	AGL	1.0	204.0	58.0	204.0
P/P	Porch	1.0	98.0	42.0	98.0

COMMENT TABLE 1

DRAWN 11/01/10 by Tina
 UPDATED BY CBAILEY 4/5/22
 UPDATED BY LK 3.6.26

COMMENT TABLE 2

2.20.26 CYCLE GM

COMMENT TABLE 3

Net LIVABLE cnt 0 (rounded) 1,186