

SKETCH/AREA TABLE ADDENDUM

SUBJECT INFO

File No.: 105689 Parcel No.: 082W29DB01100
 Property Address: 5070 DELANEY RD SE
 City: TURNER County: State: OR ZipCode: 97392
 Owner:
 Client: Client Address:
 Appraiser Name: Inspection Date:

SKETCH

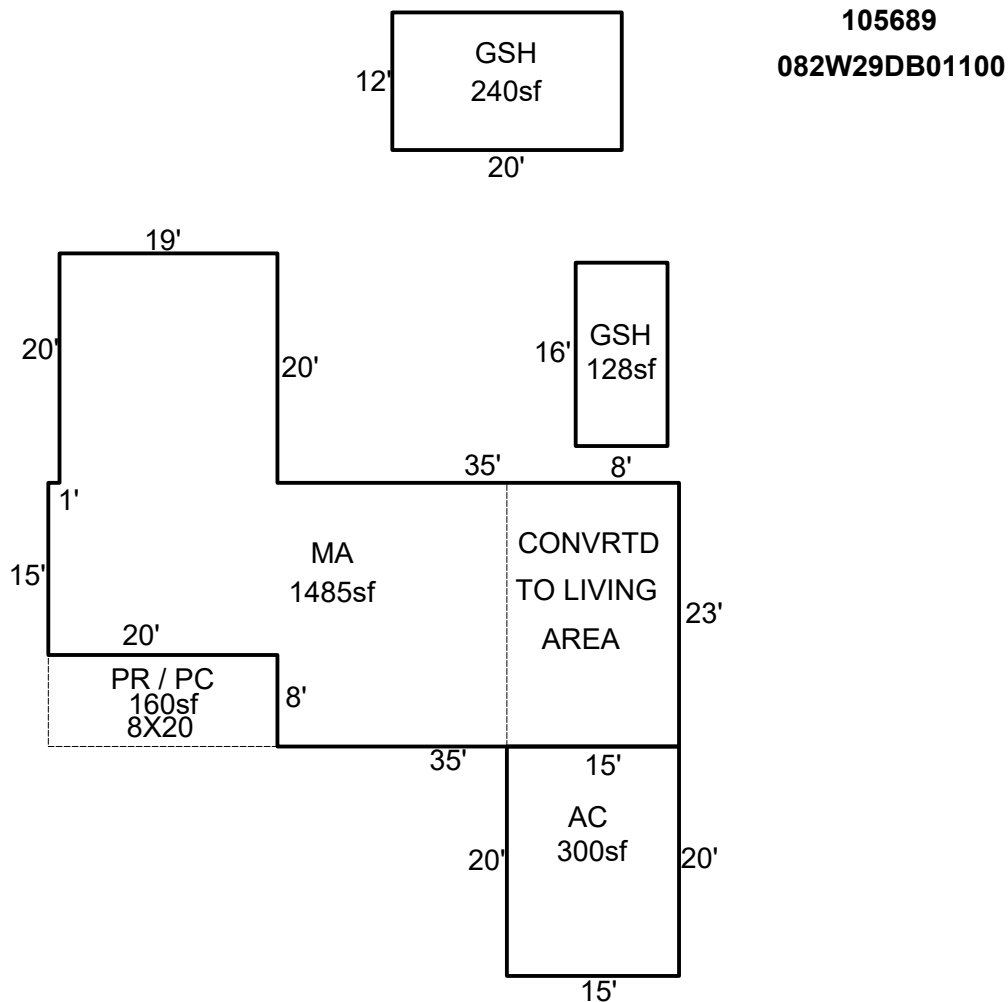

Sketch by ApexSketch

AREA CALCULATIONS SUMMARY

Code	Description	Factor	Net Size	Perimeter	Net Totals
GBA	GSH	1.0	240.0	64.0	
	GSH	1.0	128.0	48.0	368.0
GLA1	MA	1.0	1485.0	196.0	1485.0
GAR	AC	1.0	300.0	70.0	300.0
P/P	PR / PC	1.0	160.0	56.0	160.0

COMMENT TABLE 1

DRAWN BY TB 9/11/08
 UPDATED BY LK 3.6.26

COMMENT TABLE 2

2.20.26 CYCLE GM

COMMENT TABLE 3

Net LIVABLE	cnt	0	(rounded)		1,485
Net BUILDING	cnt	2	(rounded)		368