

SKETCH/AREA TABLE ADDENDUM

SUBJECT INFO

File No.: 105678 Parcel No.: 082W29DB00700
 Property Address: 5150 DELANEY RD SE
 City: TURNER County: State: OR ZipCode: 97392
 Owner:
 Client: Client Address:
 Appraiser Name: Inspection Date:

SKETCH

105678

082W29DB00700

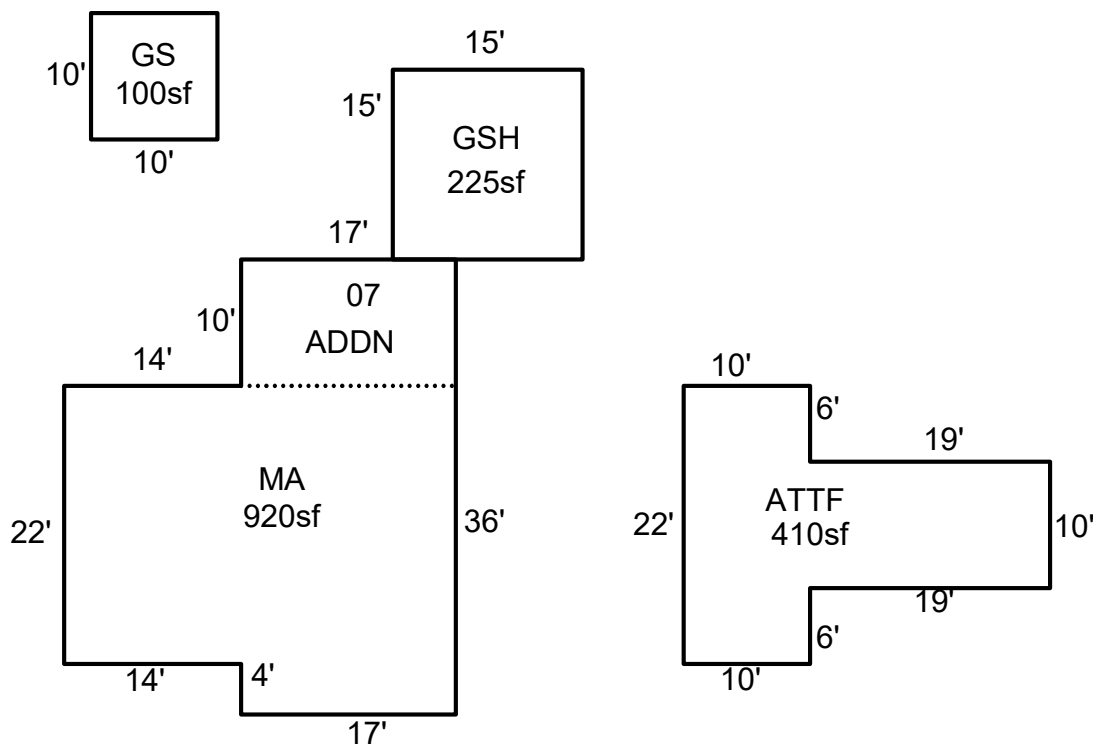

Sketch by ApexSketch

AREA CALCULATIONS SUMMARY

Code	Description	Factor	Net Size	Perimeter	Net Totals
GBA	GSH	1.0	225.0	60.0	
	GS	1.0	100.0	40.0	325.0
GLA1	MA	1.0	920.0	134.0	920.0
GLA2	ATTF	1.0	410.0	102.0	410.0

COMMENT TABLE 1

DRAWN 11/01/10 by Tina
 UPDATED BY LK 3.6.26

COMMENT TABLE 2

2.20.26 CYCLE GM

COMMENT TABLE 3

Net LIVABLE	cnt	0	(rounded)		1,330
Net BUILDING	cnt	2	(rounded)		325