

Acct ID: 514758 MTL: 052W13BD01300 Date: 8.15.25 Appr: JJS Prop Class: 551 RMV Prop Class: 451
 Situs: MaSaNh: 02 06 000 Unit: 94619 Year: 2025
 Last Date Appraised: 05/05/2010 Appraiser: JORDAN SCHULTZ Retag: Y N Tag info:
 Owner: KONEV, LAZAR Roll Type: R
cycle Tag Sales Verification Other: _____ Inspection level: 1 2 3 4 LCB TTO INSP AV: 19346
 RMV Land: 132150 RMV Imp: 44998 RMV Total: 177148 MAV: 18120 MSAV: 1226 SAV: 2303
 Comment: 22-23 NEW MP 9/14/21 WV

Notations Upd Inv

No notation data available.

OSDs

Count	Code	Description	RMV	Code Area	Exception
1	MKTF	OSD - FAIR	40000	03600	0

Land

Site: 1	Code Area: 03600	Size: 0.30 Acres	Use Code: 005	Zone: UT	SAV Use: 011	Exception: 0
Class: 4BD	Value Source: Farm Use - EFU	Description: FOUR BENCH DRY	RMV: 29130	Exception: Y	N	
Adjustment(s): GSOIL	Fire Patrol:	Description:				
Comments: Liability year - 1996 / OSD FOR GB 10300030//PER #29, CHG OF SOIL CLASS FROM 4 BENCH TO 8BENCH 06-07: RECALC SETUP;#10 09-27-05						
Site: 2	Code Area: 03600	Size: 0.59 Acres	Use Code: 005	Zone: UT	SAV Use: 011	Exception: 0
Class: 2BD	Value Source: Farm Use - EFU	Description: TWO BENCH DRY	RMV: 63020	Exception: Y	N	
Adjustment(s): GSOIL	Fire Patrol:	Description:				
Comments: Liability year - 1997						

Improvements - Residence / Manufactured Structures

No residence or manufactured structure improvement data available.

Improvements - Accessory Buildings

Bldg: 1	Code Area: 03600	Stat Class: 351	Year Blt: 1997	Eff Year Blt: 1997	Sq.Ft: 1152	% Complete: 100
Desc: General Purpose Building (GB)			Dimensions: 48x24	RMV: 36370		
Func Obsc: 100	Econ %: 100	Other %: 100	Exception: 0	Adjust:	Adjust RMV: 0	

Floors

Type	Class	Display Group	Floor Size	Beds	Baths	Yr Blt	Eff Yr Blt	Inventory	Exception
General Purpose Bldg	5	Finished	1152	0	FB-1	1997	1997	AVG, BATH - 1	Y N
GP Building Attic	5	Finished	608	0	0	1997	1997	F	Y N

Accessories

Description	Class	Size SqFt	Eff Yr Blt	RMV	Quantity	Exception
FINISHED OFFICE IN A FARM BUILDING	5	432	1997	6707	0	Y N

Bldg: 2	Code Area: 03600	Stat Class: 354	Year Blt: 1997	Eff Year Blt: 1997	Sq.Ft: 154	% Complete: 100
Desc: Lean-to Light (LTL)			Dimensions: 14x11	RMV: 290		
Func Obsc: 100	Econ %: 100	Other %: 100	Exception: 0	Adjust:	Adjust RMV: 0	

Floors

Type	Class	Display Group	Floor Size	Beds	Baths	Yr Blt	Eff Yr Blt	Inventory	Exception
Lean-to Light Duty	4	Finished	154	0	0	1997	1997		Y N

Accessories

Description	Class	Size SqFt	Eff Yr Blt	RMV	Quantity	Exception
No accessory data available						

Bldg: 3	Code Area: 03600	Stat Class: 353	Year Blt: 2005	Eff Year Blt: 2005	Sq.Ft: 200	% Complete: 100
Desc: Machine Shed (MS)			Dimensions: 10x20	RMV: 2170		
Func Obsc: 100	Econ %: 100	Other %: 100	Exception: 0	Adjust:	Adjust RMV: 0	

Floors

Type	Class	Display Group	Floor Size	Beds	Baths	Yr Blt	Eff Yr Blt	Inventory	Exception
Machine Shed	5	Finished	200	0	0	2005	2005	F	Y N

Accessories

Description	Class	Size SqFt	Eff Yr Blt	RMV	Quantity	Exception
No accessory data available						

Bldg: 4 Code Area: 03600 Stat Class: 357 Year Blt: 2016 Eff Year Blt: 2016 Sq.Ft: 225 % Complete: 100
 Desc: Frost Control Dimensions: RMV: 608
 Func Obsc: 100 Econ %: 100 Other %: 100 Exception: 0 Adjust: Adjust RMV: 0

Floors

Type	Class	Display Group	Floor Size	Beds	Baths	Yr Blt	Eff Yr Blt	Inventory	Exception: Y N
Frost Control	4	Finished	225	0	0	2016	2016		

Accessories

Description	Class	Size SqFt	Eff Yr Blt	RMV	Quantity
No accessory data available					

Bldg: 5 Code Area: 03600 Stat Class: 354 Year Blt: 2007 Eff Year Blt: 2007 Sq.Ft: 132 % Complete: 100
 Desc: Lean-to Light (LTL) Dimensions: RMV: 350
 Func Obsc: 100 Econ %: 100 Other %: 100 Exception: 0 Adjust: Adjust RMV: 0

Floors

Type	Class	Display Group	Floor Size	Beds	Baths	Yr Blt	Eff Yr Blt	Inventory	Exception: Y N
Lean-to Light Duty	4	Finished	132	0	0	2007	2007		

Accessories

Description	Class	Size SqFt	Eff Yr Blt	RMV	Quantity
No accessory data available					

Bldg: 6 Code Area: 03600 Stat Class: 341 Year Blt: 2021 Eff Year Blt: 2021 Sq.Ft: 264 % Complete: 100
 Desc: Multi Purpose Shed (MP) Dimensions: RMV: 5210
 Func Obsc: 100 Econ %: 100 Other %: 100 Exception: 0 Adjust: Adjust RMV: 0

Floors

Type	Class	Display Group	Floor Size	Beds	Baths	Yr Blt	Eff Yr Blt	Inventory	Exception: Y N
Multi-Purpose Bldg	5	Finished	264	0	0	2021	2021	F	

Accessories

Description	Class	Size SqFt	Eff Yr Blt	RMV	Quantity
No accessory data available					



SKETCH/AREA TABLE ADDENDUM

Parcel No 052W13BD01200

File No R14756

SUBJECT

Property Address 8897 PARR RD NE

City GERVAIS

State OR

Zip 97026

Owner

Client

Appraiser Name

IMPROVEMENTS SKETCH

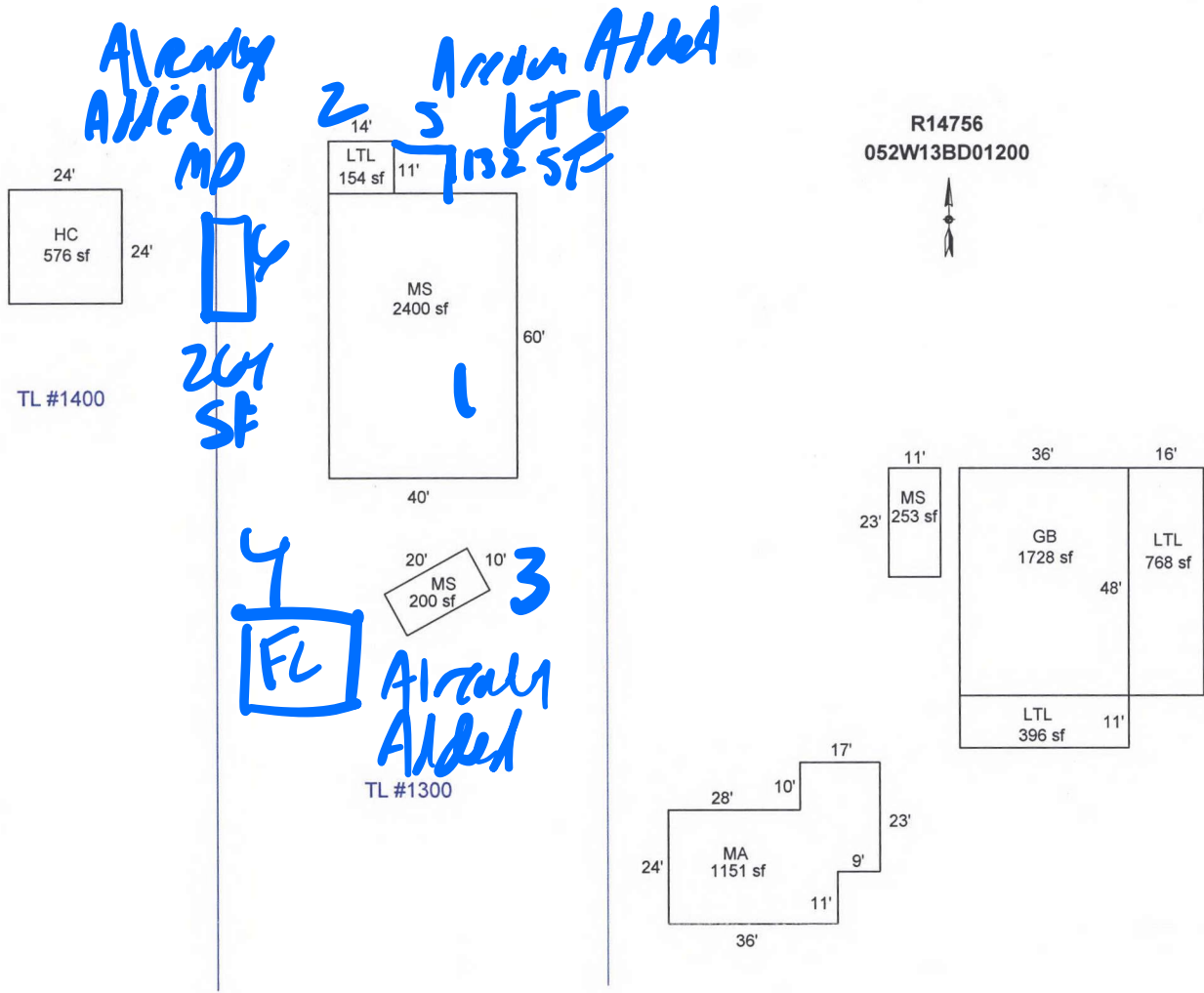

Scale: 1 = 40

AREA CALCULATIONS

AREA CALCULATIONS SUMMARY

Code	Description	Factor	Net Size	Perimeter	Net Totals
GLA1	MA	1.00	1151	158	6475
GBA1	GB	1.00	1728	168	
	LTL	1.00	396	94	
	MS	1.00	253	68	
	LTL	1.00	768	128	
	MS	1.00	2400	200	
	MS	1.00	200	60	
	HC	1.00	576	96	
	LTL	1.00	154	50	
	Net LIVABLE Area	(rounded w/ factors)			1151
	Net BUILDING Area	(rounded w/ factors)			6475

Comment Table 1

APEX BY CE 5/17/10

Comment Table 2

JJS
8.1.25

Comment Table 3

Cycle
L3