

Summary

Lead Appr: W/W Clerk: _____ Lead Clerk: _____ Appr: MLH 2/6/26

Print Date:

9/26/2025

Acct ID: 521457 MTL: 071W14000600 Date: 1/14/26 Appr: MLH Prop Class: 581 RMV Prop Class: 501
Situs: 2886 EDISON RD NE SILVERTON OR 97381 MaSaNh: 03 06 000 Unit: 41461 Year: 2025

Last Date Appraised: 12/04/2024 Appraiser: MATTHEW HAMILTON Tag: Y N Tag info: 2026 - NEW CONSTRUCTION (Residence)

Owner: KEVIN E & SHERRI G POOLE RLT & Last Sales Date: 11/17/2010 Roll Type: R

Cycle Tag Sales Verification Other: _____ Inspection level: 1 2 3 4 LCB TTO INSP AV: 325354

RMV Land: 505300 RMV Imp: 631910 RMV Total: 1137210 MAV: 22210 MSAV: 22424 SAV: 32398

Comment: 25-26: L1 12.4.24 MLH
24-25: L2 1.4.24 MLH

MA @ 100% close Tag

Input MLH 1/27/26

Notations

RP/MS	Code	Description
MS	STF	SMALL TRACT FORESTLAND
MS	ZONED	FARM EFU ZONED

*Farm seed
Fodest OK*

OSDs

Count	Code	Description	RMV	Code Area	Exception
2	SAN	SA OSD - NO LANDSCAPE <i>A</i>	35000	04500	0

Land

Site: 1 Code Area: 04500 Size: 7.88 Acres Use Code: 005 Zone: REST SAV Use: 011 Exception: 0
 Class: 4HD Value Source: Farm Use - EFU Description: FOUR HILL DRY RMV: 92060 Exception: Y N
 Adjustment(s): FSOIL, WASTE Fire Patrol: SA004 Description: FIRE PATROL
 Comments: Liability year - 1974
 25-26: Land classes ok, change 5.75 acres STFC to STFX
 06-07: RECALC SETUP;#36, 08-05-05

Site: 3 Code Area: 04500 Size: 1.00 Acres Use Code: 005 Zone: REST SAV Use: 011 Exception: 0
 Class: 6H Value Source: Farm Homesite Description: SIX HILL RMV: 11100 Exception: Y N
 Adjustment(s): FSOIL, WASTE Fire Patrol: SA004 Description: FIRE PATROL
 Comments: Liability year - 2011

Site: 4 Code Area: 04500 Size: 31.25 Acres Use Code: 005 Zone: REST SAV Use: 011 Exception: 0
 Class: STFC Value Source: Small Tract Forest land Description: SMALL TRACT FORESTLAND C RMV: 365120 Exception: Y N
 Adjustment(s): FSOIL, WASTE Fire Patrol: SA004 Description: FIRE PATROL
 Comments: Liability year - 1974, STF - 2004 / 400008: 03-04: EXPIRATION OF STO PROGRAM. CONVERSION BY DOR TO DESIGNATED FOREST LAND AT 100% PROGRAM. // 04-05: CHANGING STO LAND FROM >5000 TO DESIGNATED /04-05: STF APPROVED 06-07: RECALC SETUP;#36, 08-05-05

Site: 5 Code Area: 04500 Size: 5.75 Acres Use Code: 005 Zone: REST SAV Use: 011 Exception: 0
 Class: STFX Value Source: Small Tract Forest land Description: SMALL TRACT FORESTLAND X RMV: 2020 Exception: Y N
 Adjustment(s): FSOIL, WASTE Fire Patrol: SA004 Description: FIRE PATROL
 Comments: Liability year - 1974, STF - 2004

Improvements - Residence / Manufactured Structures

Bldg: 3 Code Area: 04500 Stat Class: 151 Year Blt: 2024 Eff Year Blt: 2024 Sq.Ft: 3301 % Complete: 70.00
 Desc: One Story Only Dimensions: RMV: 588360
 Func Obsc: 100 Econ %: 100 Other %: 100 Exception: 280720 Adjust: Adjust RMV: 0

Floors

Type	Class	Display Group	Floor Size	Beds	Baths	Yr Blt	Eff Yr Blt	Inventory	Exception
First Floor	5	Finished	3301	3	FB-3/ HB-1	2024	2024	HVAC+, KIT, ROOF, BATH - 3, BTH - 1, BATH+	Y N
Garage Attached	5	Finished	1158	0	0	2024	2024	ROOF	Y N

Accessories

Description	Class	Size SqFt	Eff Yr Blt	RMV	Quantity	Exception
YARD IMPROVEMENTS AVERAGE	5	0	2024	31220	1	Y N

Improvements - Accessory Buildings

Bldg: 1 Code Area: 04500 Stat Class: 341 Year Blt: 2010 Eff Year Blt: 2010 Sq.Ft: 120 % Complete: 100.00
 Desc: Multi Purpose Shed (MP) Dimensions: 12x10 RMV: 2500
 Func Obsc: 100 Econ %: 100 Other %: 100 Exception: 0 Adjust: Adjust RMV: 0

Floors

Type	Class	Display Group	Floor Size	Beds	Baths	Yr Blt	Eff Yr Blt	Inventory	Exception
Multi-Purpose Bldg	5	Finished	120	0	0	2010	2010	FAIR	Y N

Accessories

Description	Class	Size SqFt	Eff Yr Blt	RMV	Quantity
-------------	-------	-----------	------------	-----	----------

No accessory data available

Bldg: 2	Code Area: 04500	Stat Class: 351	Year Blt: 2011	Eff Year Blt: 2011	Sq.Ft: 2400	% Complete: 100.00
Desc: General Purpose Building (GB)			Dimensions: 60x40		RMV: 41050	
Func Obsc: 100	Econ %: 100	Other %: 100	Exception: 0	Adjust:	Adjust RMV: 0	

N/L

Floors

Type	Class	Display Group	Floor Size	Beds	Baths	Yr Blt	Eff Yr Blt	Inventory	Exception: Y N
General Purpose Bldg	5	Finished	2400	0	0	2011	2011	AVG	

Accessories

Description	Class	Size SqFt	Eff Yr Blt	RMV	Quantity
-------------	-------	-----------	------------	-----	----------

No accessory data available

Farm Notes

2025FARM

25-26: Per CWO 3-10-25, Owner has attempted to replant logged area twice and has had issues with soil disease. Worked with state forester and MCSWD to remedy with no luck. Change 5.75 acres of STFC to STF.



SKETCH/AREA TABLE ADDENDUM

SUBJECT INFO

File No.: 521457 Parcel No.: 071W14 00600
 Property Address: 2886 EDISON ROAD NE
 City: SILVERTON County: MARION State: OR ZipCode: 97381
 Owner:
 Client: Client Address:
 Appraiser Name: Inspection Date:

SKETCH

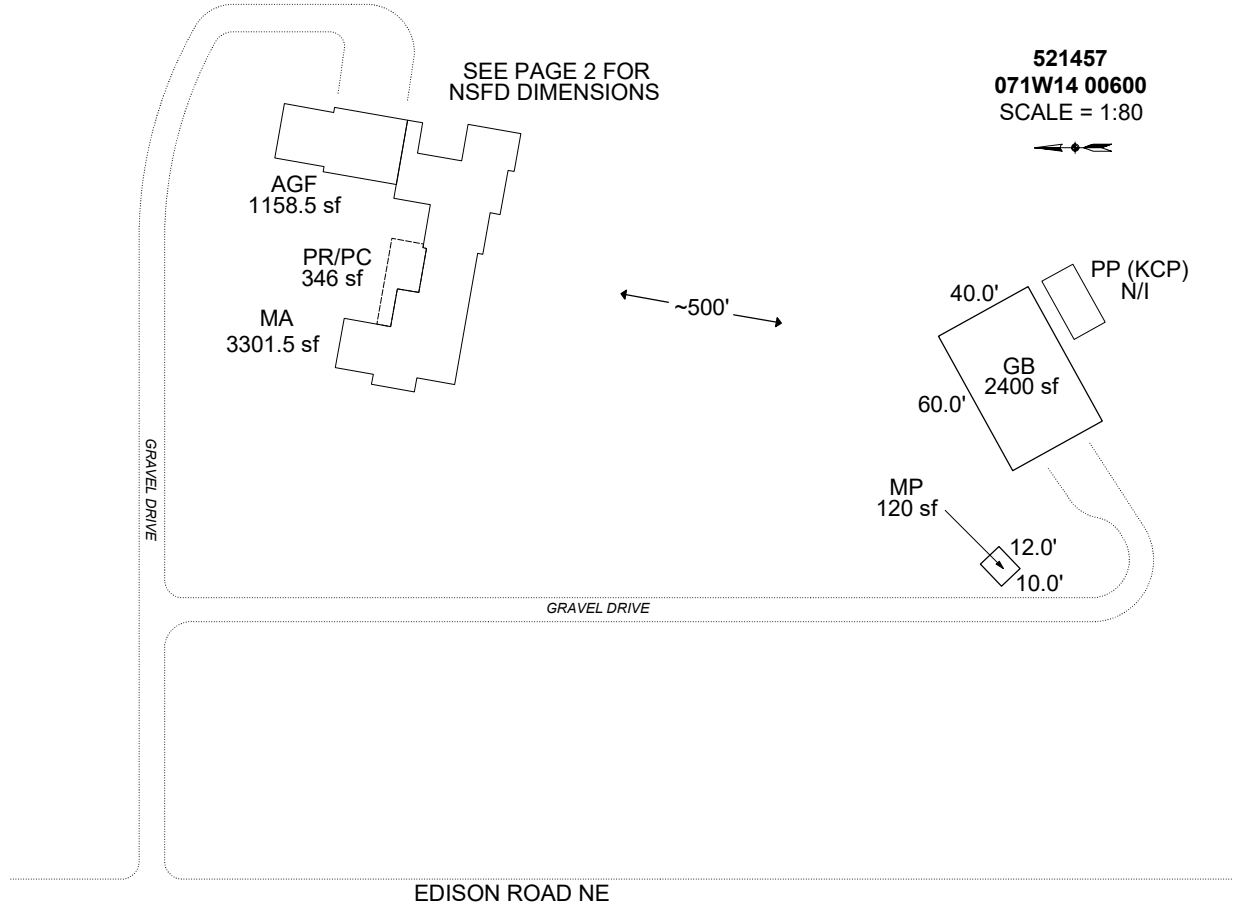

Sketch by ApexSketch

AREA CALCULATIONS SUMMARY

Code	Description	Factor	Net Size	Perimeter	Net Totals
GBA1	GB	1.0	2400.0	200.0	
	MP	1.0	120.0	44.0	2520.0
GLA1	MA	1.0	3307.8	380.0	3307.8
GAR	AGF	1.0	1158.8	148.0	1158.8
P/P	PR/PC	1.0	346.3	96.0	346.3

COMMENT TABLE 1

Apex 1/27/2011 Jane
 UPDATED BY CJURAN 09/13/2023 555-23-004794
 UPDATED BY CJURAN 01/08/2024
 UPDATED BY CLOBERG 12/05/24

COMMENT TABLE 2

MLH 01/04/2024
 MLH 12/04/24

MLH 1/14/26

COMMENT TABLE 3

TAGS L2
 TAGS L1

Tags L2

Net LIVABLE	cnt	0	(rounded)		3,308
Net BUILDING	cnt	2	(rounded)		2,520

SKETCH/AREA TABLE ADDENDUM

SUBJECT INFO

File No.: 521457 Parcel No.: 071W14 00600
 Property Address: 2886 EDISON ROAD NE
 City: SILVERTON County: MARION State: OR ZipCode: 97381
 Owner:
 Client: Client Address:
 Appraiser Name: Inspection Date:

SKETCH

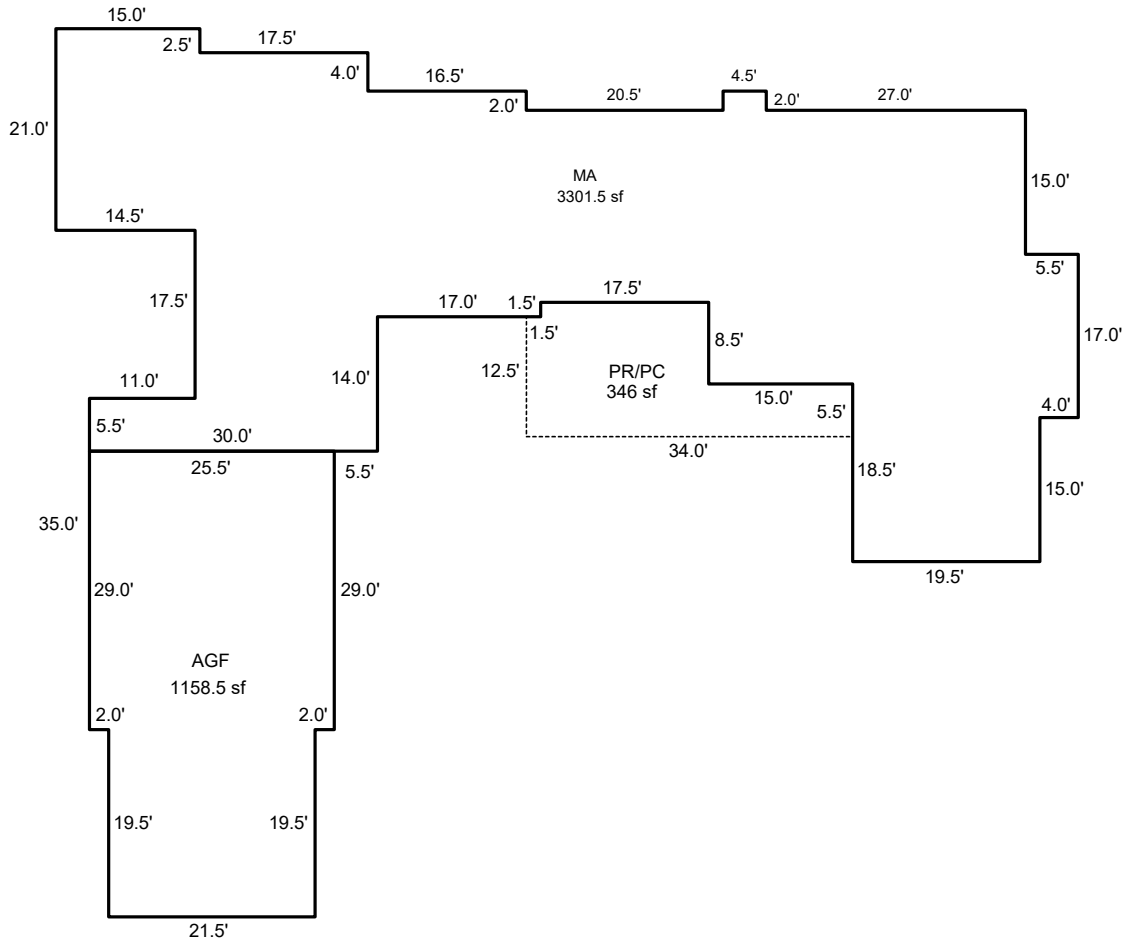

Sketch by ApexSketch

AREA CALCULATIONS SUMMARY

Code	Description	Factor	Net Size	Perimeter	Net Totals
GLA1	MA	1.0	3295.8	381.0	3295.8
GAR	AGF	1.0	1158.8	148.0	1158.8
P/P	PR/PC	1.0	346.3	96.0	346.3

COMMENT TABLE 1

Apex 1/27/2011 Jane
 UPDATED BY CJURAN 09/13/2023 555-23-004794
 UPDATED BY CJURAN 01/08/2024
 UPDATED BY CLOBERG 12/05/24

COMMENT TABLE 2

MLH 01/04/2024
 MLH 12/04/24

COMMENT TABLE 3

TAGS L2
 TAGS L1

Net LIVABLE cnt 0 (rounded) 3,296