

# SKETCH/AREA TABLE ADDENDUM

## SUBJECT INFO

File No.: 105466 Parcel No.: 081W34DB02900  
 Property Address: 222 E MAIN ST  
 City: SUBLIMITY County: Marion State: OR ZipCode: 97385  
 Owner:  
 Client: Client Address:  
 Appraiser Name: Inspection Date:

## SKETCH

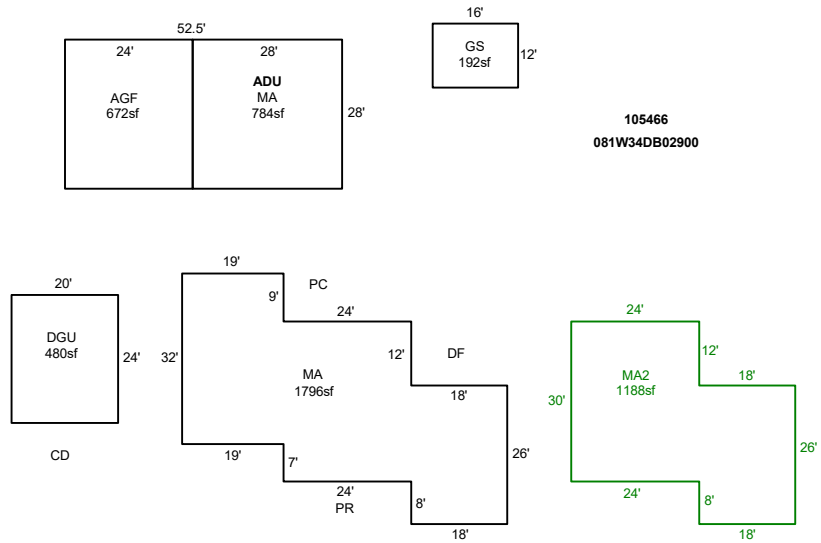

Sketch by ApexSketch

### AREA CALCULATIONS SUMMARY

Code	Description	Factor	Net Size	Perimeter	Net Totals
GBA	GS	1	192	56	192
GLA	MA	1	1796	216	
	MA	1	784	112	2580
GLA2	MA2	1	1188	160	1188
GAR	DGU	1	480	88	
	AGF	1	672	104	1152

### COMMENT TABLE 1

Drawn by vwiegand 3/31/11  
 Updated by AE 12.15.25  
 UPDATED BY LK 1.6.26

### COMMENT TABLE 2

7/20/21 #72 Cycle  
 12.9.25 TAG GM

### COMMENT TABLE 3

Net LIVABLE cnt 2 (rounded) 3,768  
 Net BUILDING cnt 1 (rounded) 192