

Acct ID: 330448 MTL: 093W23A001900 Date: **11/20/25** Appr: **MOL** Prop Class: 641 RMV Prop Class: 401
 Situs: 12174 TIMBER LN SE JEFFERSON OR 97352 MaSaNh: 07 06 006 Unit: 51333 Year: 2025

Last Date Appraised: 01/20/2013 Appraiser: MATT LORD Tag: **Y** N Tag info: 2026 - NEW CONSTRUCTION (Outbuilding)
 Owner: SPIRES, TREVOR W & SPIRES, LISA D Last Sales Date: 12/15/2008 Roll Type: R
 Cycle: **Tag** Sales Verification Other: _____ Inspection level: 1 **2** 3 4 LCB TTO INSP AV: 413590
 RMV Land: 335900 RMV Imp: 866220 RMV Total: 1202120 MAV: 412880 MSAV: 710 SAV: 1379
 Comment: **25-001150** **BAED**

Notations **26-27: 48x36 GB 85% complete; Discoved Solar Permit # 24-001922 \$40,000**

RP/MS	Code	Description
RP	DFL	DESIGNATED FORESTLAND

OSDs

Count	Code	Description	RMV	Code Area	Exception
1	MKTF	OSD - FAIR AVB	40000	14530	0

Land

Site: 1 Code Area: 14530 Size: 3.04 Acres Use Code: 004 Zone: NREST SAV Use: 011 Exception: 0
 Class: FTLF Value Source: Designated Forest Land Description: DFL Class F RMV: 174670 Exception: Y N
 Adjustment(s): FSOIL Fire Patrol: Description:
 Comments: Liability year - 2004 / 02-03: 32 AC DISQ FOREST LAND / 02-03: F02-261 DELETE FOR NEW SUB, CREATING R330441 THRU R330448 /03-04: INDIAN WELLS SUBDIVISION MERGING INTO SURROUNDING AREA . 2003-04 REAPPRAISAL. //04-05: FOR APP RECEIVED AND APPROVED 04-05: RECALC PROJECT, LAND SCHEDULE CHANGES. 04-05: F04-0522 LLA BETWEEN R330443,R330448 07-08: RECALC SETUP; #31 10/16/06

Site: 2 Code Area: 14530 Size: 1.00 Acres Use Code: 004 Zone: NREST SAV Use: Exception: 0
 Class: 6H Value Source: Market Homesite Description: SIX HILL RMV: 57450 Exception: Y N
 Adjustment(s): FSOIL Fire Patrol: Description:
 Comments: 2012-13: HOMESITE ADDED// 02-03: 32 AC DISQ FOREST LAND. 02-03: F02-261 DELETE FOR NEW SUB, CREATING R330441 THRU R330448. 03-04: INDIAN WELLS SUBDIVISION MERGING INTO SURROUNDING AREA; 2003-04 REAPPRAISAL. 04-05: RECALC PROJECT, LAND SCHEDULE CHANGES. 04-05: F04-0521 LLA BETWEEN R330443 & R60783 - IMPS NOT MOVING. 04-05: F04-0522 LLA BETWEEN R330443,R330448

Site: 4 Code Area: 14530 Size: 1.11 Acres Use Code: 004 Zone: NREST SAV Use: Exception: 0
 Class: 6H Value Source: Rural at MKT Description: SIX HILL RMV: 63780 Exception: Y N
 Adjustment(s): FSOIL Fire Patrol: Description:
 Comments: 10-11: DISQ FOREST USE

Improvements - Residence / Manufactured Structures

Bldg: 1 Code Area: 14530 Stat Class: 153 - Year Blt: 2011 Eff Year Blt: 2011 Sq.Ft: 4150 % Complete: 100.00
 Desc: One Story with basement Dimensions: RMV: 866220
 Func Obsc: 100 Econ %: 100 Other %: 100 Exception: 0 Adjust: Adjust RMV: 0

Floors

Type	Class	Display Group	Floor Size	Beds	Baths	Yr Blt	Eff Yr Blt	Inventory	Exception
First Floor	5 -	Finished	2207	1	FB-1/ HB-1	2011	2011	FP - 1, BATH+, KIT+, BTH - 1, ROOF, HVAC, BATH - 1	Exception: Y N
Basement	5 -	Finished	1943	3	FB-2	2011	2011	FP - 1, HVAC, BATH - 2	Exception: Y N
Garage Attached	5	Finished	948	0	0	2011	2011	ROOF	Exception: Y N

Accessories

Description	Class	Size SqFt	Eff Yr Blt	RMV	Quantity	Exception
YARD IMPROVEMENTS GOOD	5	1	2011	52405	1	Exception: Y N

Permits

Permit Number	Permit ID	Origin	Category	Type	Estimate Value	% Complete	Roll Type	Description
25-001150	83594	MARION COUNTY	NEW CONSTRUCTION	OUTBUILDING	55452	0	R	48 X 36 Pole Barn, No plmg

GB
5
36x48
FAIR
2025
85% compl.

Solar
\$40,000
24-001922

SKETCH/AREA TABLE ADDENDUM

SUBJECT INFO

File No.: 330448 Parcel No.: 093W23A 01900
 Property Address: 12174 TIMBER LN
 City: JEFFERSON County: MARION State: OR ZipCode: 97352
 Owner:
 Client: Client Address:
 Appraiser Name: Inspection Date:

SKETCH

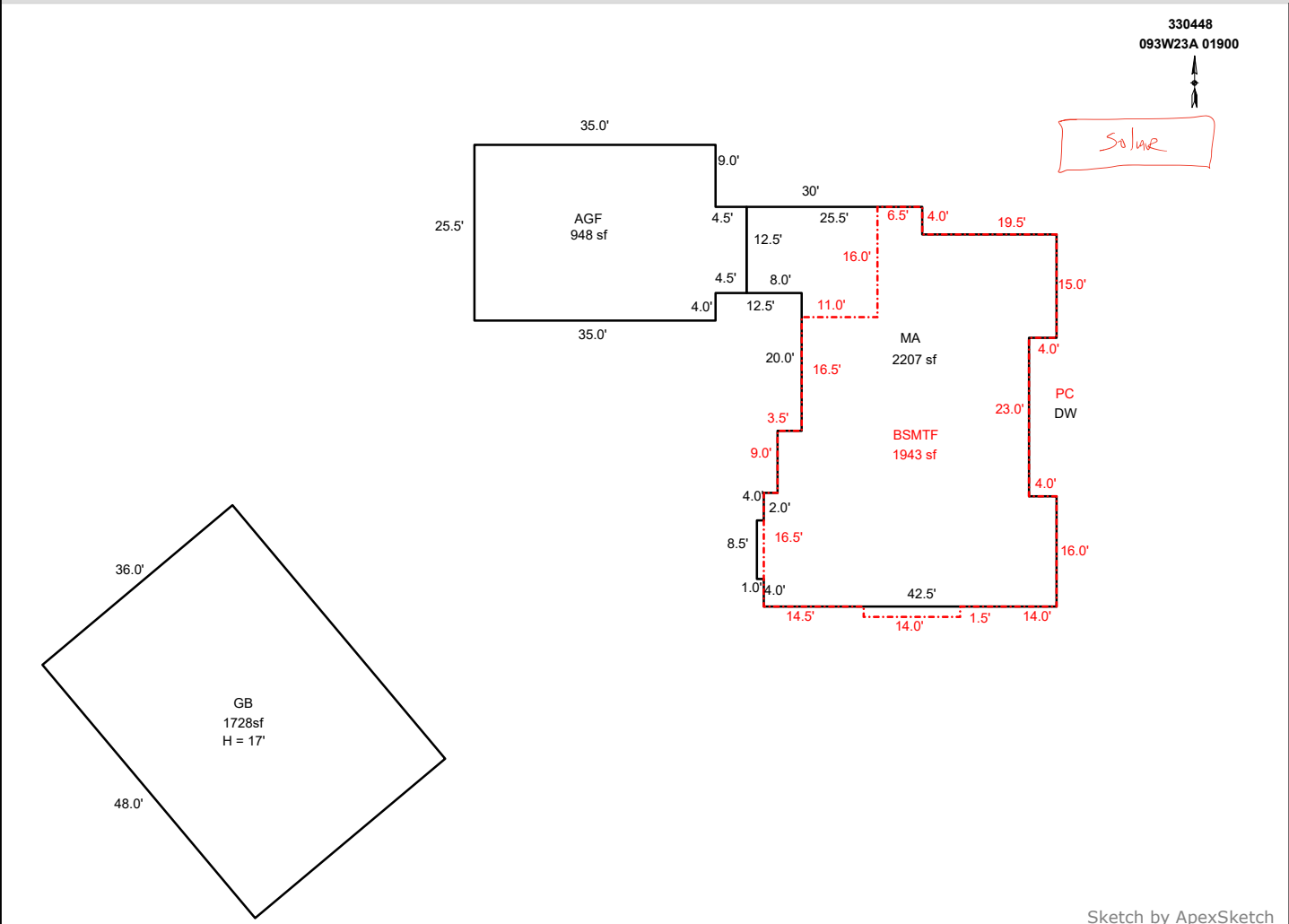

AREA CALCULATIONS SUMMARY

Code	Description	Factor	Net Size	Perimeter	Net Totals
GBA1	GB	1.0	1728.0	168.0	1728.0
GLA0	BSMTF	1.0	1943.3	212.0	1943.3
GLA1	MA	1.0	2206.8	227.0	2206.8
GARAGE	AGF	1.0	948.8	130.0	948.8

COMMENT TABLE 1

DRAWN BY SH 10-11-11
 UPDATED BY CLOBERG 05/19/25 25-001150 GB

COMMENT TABLE 2

COMMENT TABLE 3

Net LIVABLE	cnt	0	(rounded)	4,150
Net BUILDING	cnt	1	(rounded)	1,728



11/20/25

APPR _____ Date _____ YR For _____ % COMP _____
 APPR _____ Date _____ YR For _____ % COMP _____
 APPR _____ Date _____ YR For _____ % COMP _____
 APPR _____ Date _____ YR For _____ % COMP _____

Outbuilding Type: GB

	% Item	% Sum
Excavation/Foundation	10% ✓	40%
Floor - Concrete/Wood	30% ✓	
Walls - Framing	10% ✓	65%
Walls - Covering/Siding	15%	
Roof - Framing/Trusses	15% -	95%
Roof - Sheathing	5% ✓	
Roof - Cover	10% ✓	
Doors & Windows	5%	100%

*Stopped
 Revisions to plans
 Oct 2025
 25%*

APPR MOL Date 11/24/25 YR For 26-27 % COMP 95%
 APPR _____ Date _____ YR For _____ % COMP _____
 APPR _____ Date _____ YR For _____ % COMP _____
 APPR _____ Date _____ YR For _____ % COMP _____









X

093W23A 01900 R330448 R330448
400 02F 81400130
HERR CONSTRUCTION, INC

5.04 Acres
INDIAN WELLS ESTATES, LOT 8, ACRES 5.04

12174 TIMBER LN SE

BUILDING DIAGRAM AND OUTBUILDINGS

ACCT NO: R 330448

MAP NO: 93W-23A

TAX LOT: 900

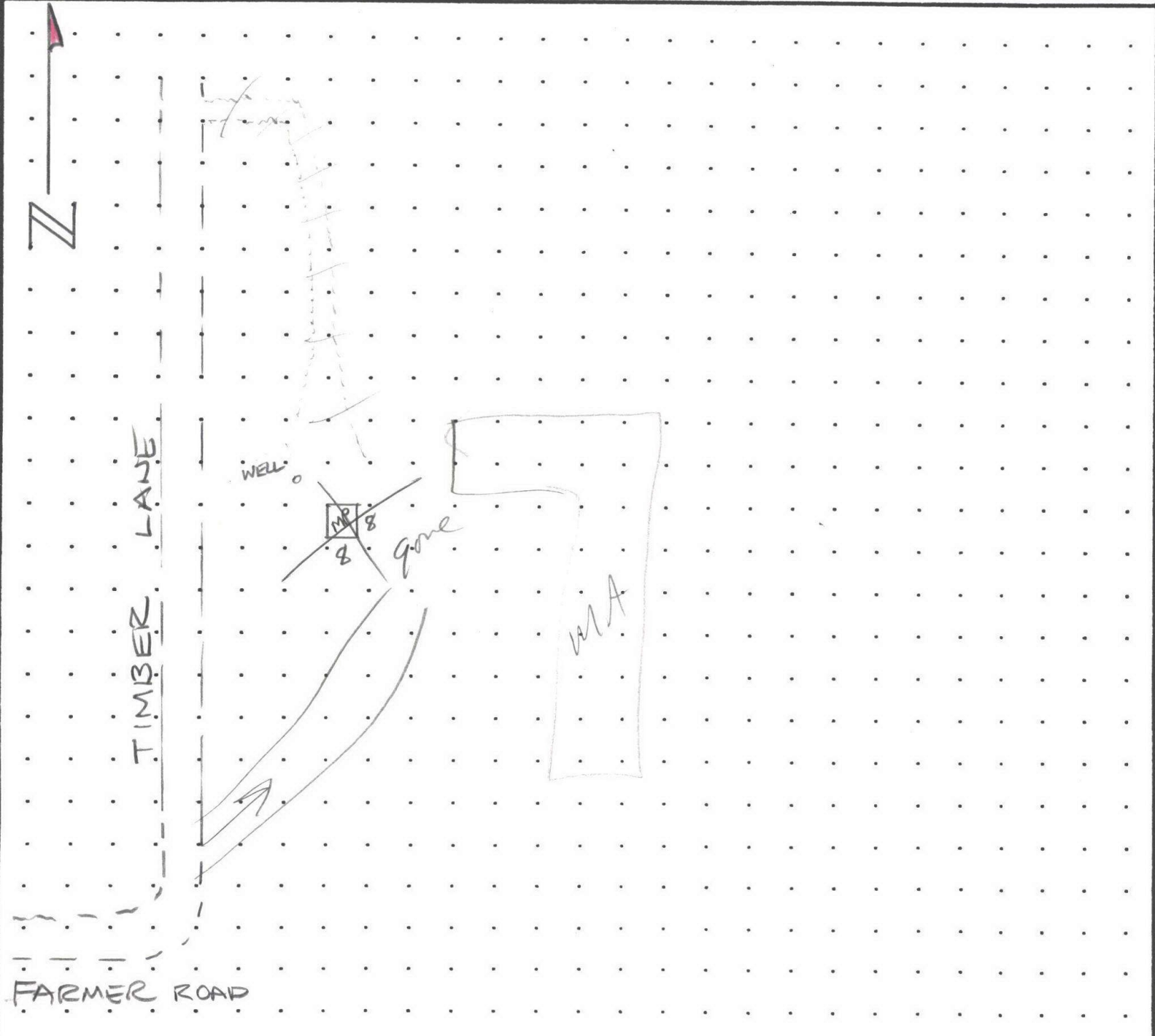

CALCULATIONS:

SCALE: 1" = 20'

MEASUREMENT VERIFIED

YR BLT:

ADDRESS: 12174 TIMBER LN SE

SALES
Date Amt.

DATE
10/16/08
7-17-09
1-29-13

BY
31
42
73

REMARKS:

BUILDER:

NO DEMO'S, TRUSS CLEANED

SALES	
Date	Amt.

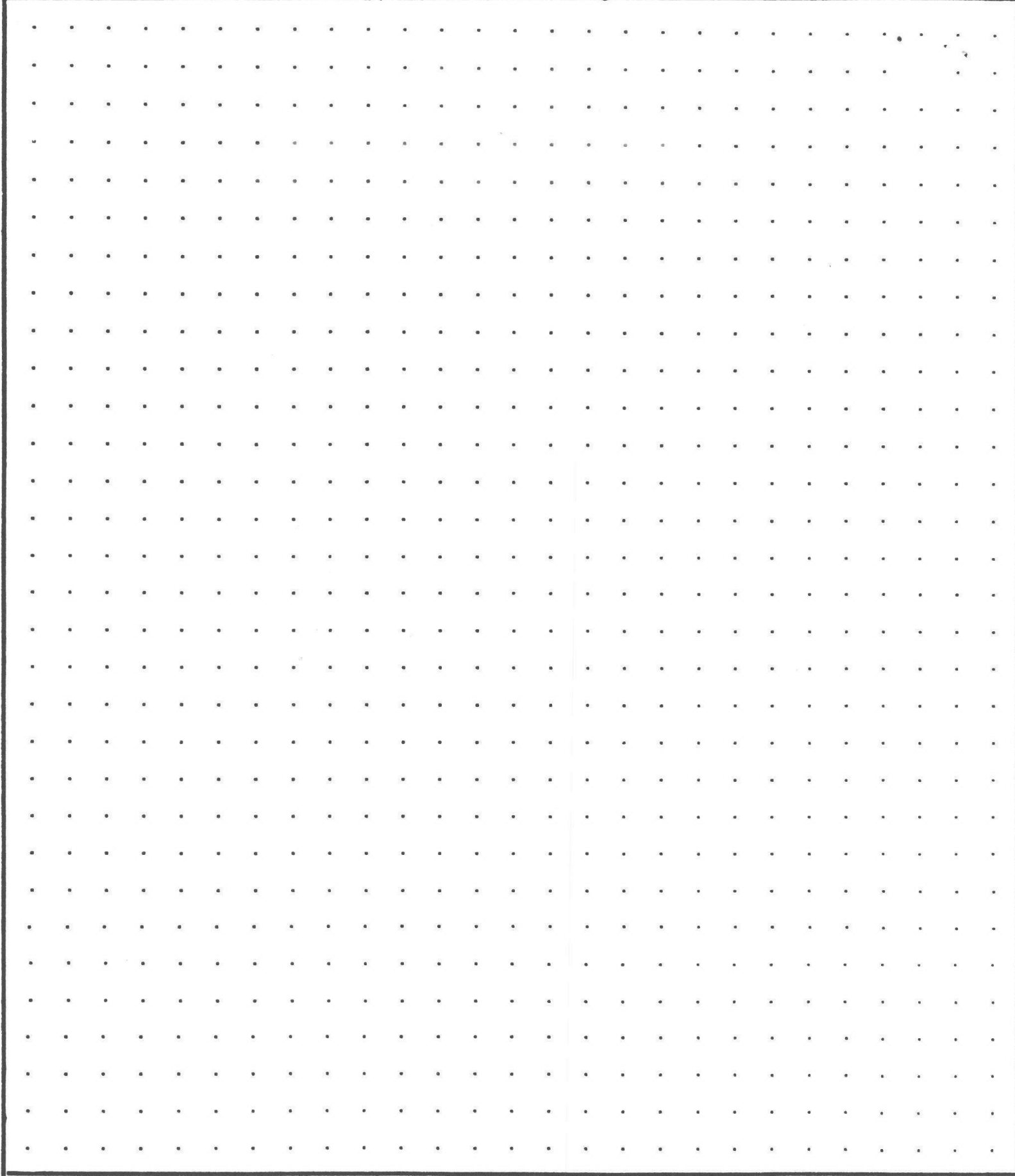

CALCULATIONS:

SCALE: 1" = 20'

BUILDING DIAGRAM AND OUTBUILDINGS

ACCT NO:

MAP NO:

TAX LOT:

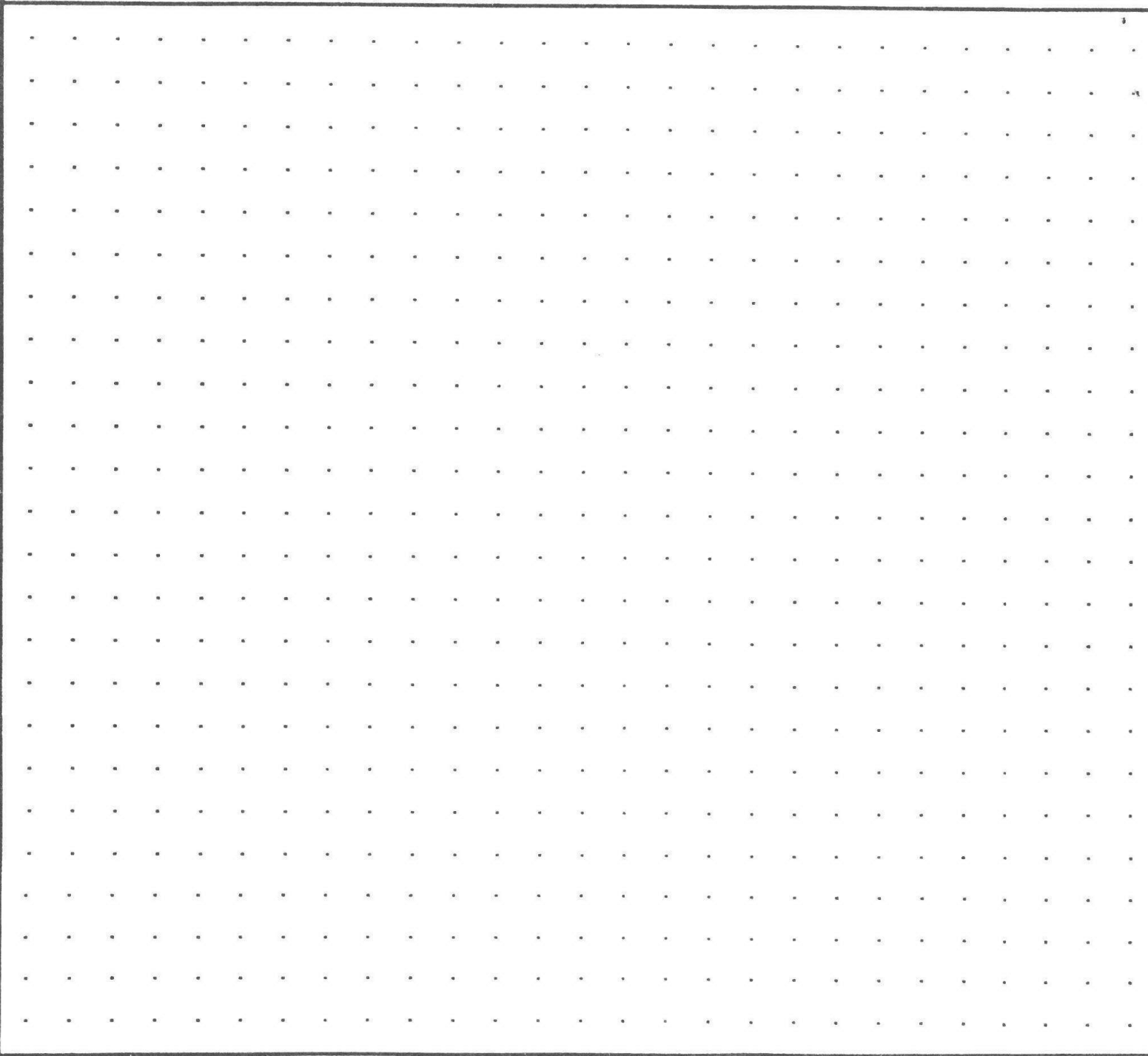

CALCULATIONS:

SCALE: 1" = 20'

MEASUREMENT
VERIFIED

YR BLT:

ADDRESS: *12174 Timber Ln*

SALES
Date Amt.

DATE
3-2-12

BY
73

NEWMA
REMARKS:

BUILDER:

Date	Amt.

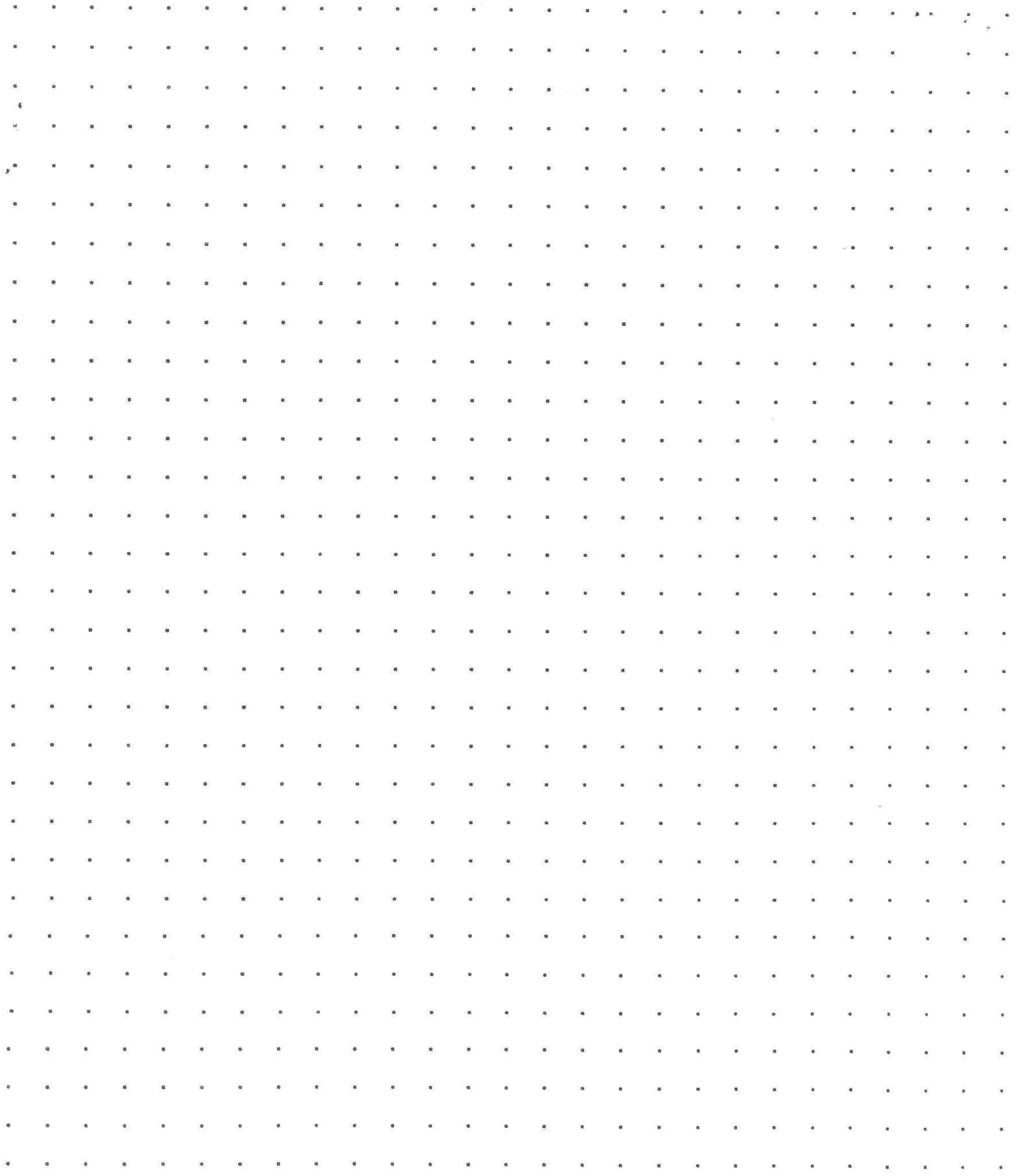

CALCULATIONS:

SCALE: 1" = 20'

SKETCH/AREA TABLE ADDENDUM

Parcel No 093W23A 01900

File No R330448

SUBJECT

Property Address 12174 TIMBER LN

City JEFFERSON

County MARION

State OR

Zip 97352

Owner

Client

Appraiser Name

IMPROVEMENTS SKETCH

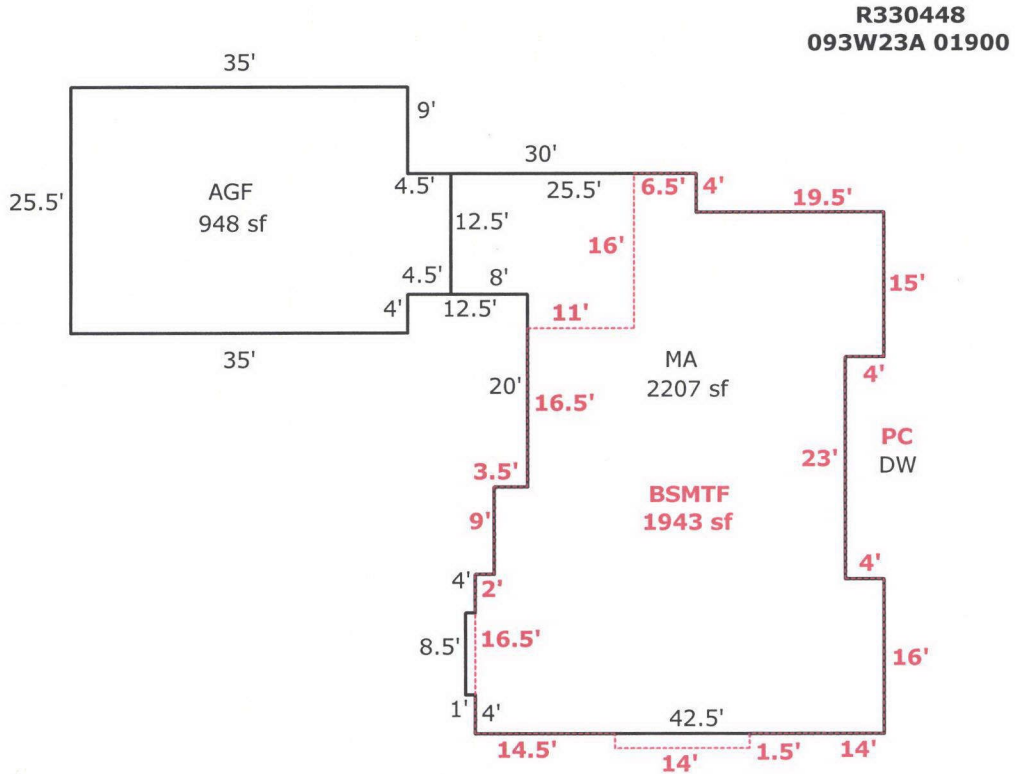

Scale: 1 = 20

AREA CALCULATIONS

AREA CALCULATIONS SUMMARY

Code	Description	Factor	Net Size	Perimeter	Net Totals
GLA1	MA	1.00	2206.8	227.0	2206.8
GLA0	BSMTF	1.00	1943.3	212.0	1943.3
GARAGE	AGF	1.00	948.8	130.0	948.8

Comment Table 1

DRAWN BY SH 10-11-11

Comment Table 2

Comment Table 3

Net LIVABLE Area (rounded w/ factors) 4150

R330448 093W23A 01900 Appr #: 73 Date 1-20-13 Prop Class 641 Prop Code A95

Situs Address 12174 TIMBER LN SE Franchise Code 73 Year For: 2013-2014

Owner SPIRES, TREVOR W &

Notes: NOA Tags Cycle Sales Verification 100% Other: Poll Tag
ADD G/T/OSDF

RMV Land: 172,020 RMV Imp: 159,300 RMV Total: 331,320 M50 Total: 181,170

Seg.Type MA Seg. # 1.1 Method: R05 Class 5 Area 2207 Eff Area 2207
Length Width Roof Cover ARCOMP Plumbing BATH1.5;GRDNTUB Heat FA
Fireplace PREFB-P Inter. Comp: CKTP-E;DSP;DW;MICRO;OVEN-S Bedrooms 1
Year Built 2011 Eff. Year Built 2011 Cond. P F A G E
Adj Codes RLCM5;COMPL;R5-QLTY Qty 5 % Comp 100 Func Econ RMV: 79,770
Lump Sum Except Code/Year M Comments BRING TO 100%

Seg.Type BSMTF Seg. # 1.2 Method: R05 Class 5 Area 1943 Eff Area 1943
Length Width Roof Cover Plumbing BATH2 Heat FA
Fireplace PREFB-P Inter. Comp: Bedrooms 3
Year Built 2011 Eff. Year Built 2011 Cond. P F A G E
Adj Codes RLCM5;COMPL;R5-QLTY Qty 5 % Comp 100 Func Econ RMV: 56,810
Lump Sum Except Code/Year M Comments BRING TO 100%

Seg.Type AGF Seg. # 1.3 Method: R05 Class 5 Area 948 Eff Area 948
Length Width Roof Cover ARCOMP Plumbing Heat
Fireplace Inter. Comp: Bedrooms
Year Built 2011 Eff. Year Built 2011 Cond. P F A G E
Adj Codes RLCM5;COMPL Qty 5 % Comp 100 Func Econ RMV: 22,720
Lump Sum Except Code/Year M Comments BRING TO 90 100

Accessory Improvements

Out Buildings

R330448 093W23A 01900 Appr #: _____ Date _____ Prop Class 641 Prop Code A95
 Situs Address 12174 TIMBER LN SE Franchise Code 73 Year For: 2013-2014
 Owner SPIRES, TREVOR W &

Tags _____ Cycle _____ Sales Verification _____ Other: _____

Notes: _____

RMV Land: 172,020 RMV Imp: 159,300 RMV Total: 331,320 M50 Total: 181,170

Segment	Q156								Land
Class	5								
Dim/Size									
Foundation									
Exter Wall									
Wall Height									
Inter Finish									
Roof Cover									
Roof Style									
Flooring									
Plumbing									
Electric									
Misc.									
Yr Blt	2012								
Eff Yr	2012								
Cond.	A								
% Good	100								
% Comp	100								
Lump Sum									
Except. Code	NEW								

1008D

Land Segments

Seg. No	Description	Schedule	Acres	Adjustment Codes	Exception Code
1	DESIG FOREST FC0	008S	3.04		
2	MARKET HOMESITE	008S	1.00		
3	ON SITE DEVELOPMENT	OSDN .RUR		OSDF, RUR	
4	RURAL AT MKT	008S	1.11	TREED 10000	

Eff Acres _____ Companion Accounts _____

Lian

Date 2/14 Clerk Amy **ROUTING SLIP**

Work Needed: (Please make necessary comments, sign and pass to the next appropriate person.)

- Data entry reviewed by/comments _____
- APEX: Please review and return appraisal jacket to clerical staff for Apex attachment to TSG.
- Appraiser response _____
- Reviewed by lead appraiser/comments _____

- - Improvement Maintenance BEFORE EXCEPTION - -

Property ID: R330448 093W23A 01900

Imp 1 Of 1

Owners Name: SPIRES,TREVOR W &

Nbhd:SW.RUR

Living Area/Value : 4,150 / \$136,580

- | | | | |
|-----------------|---|-----------------|----------------|
| 1. Type Imp | : R | 7. Appr Method | : C Cost Value |
| 2. Description | : RESIDENTIAL | 8. Cost Value | : \$159,300 |
| 3. Bldg Type | : | 9. Income Value | : \$0 |
| 4. Cmplx/Bldg | : | 10. Trend Adj% | : |
| 5. M/S Zip Code | : 97352 | RMV Imprv | : \$159,300 |
| 6. Comment | : 13-14: RES @ 100%, ADD YI'S /2012-13: ADD NEW RES,AGF @ 60% AND | | |

- - Improvement Segments - -

Seg ID	Type - Description.....	Class	Area	Mthd	RMV Total
S1	MA - MAIN AREA	5	2207+	R05	\$79,770
S2	BSMTF - BASEMENT, FINISHE	5	1943+	R05	\$56,810
S3	AGF - ATTACHED GARAGE, FI	5	948	R05	\$22,720
Totals:			4150		\$159,300

T-Trend

CM-Comment

S*-Add Seg

(.) More

Enter Field #, Seg ID, or <RET> to Exit:

- - Land Detail (Market) BEFORE EXCEPTION - -

Property ID: R330448 093W23A 01900	Segment 3 Of 4
1. Type Land : OSD (ON SITE DEVELOPM	11. Appr Method : LT
2. Prop Class : Primary: 641	12. Appr Year : 2013
3. Land Class :	13. Land Table : OSDN.RUR
4. Nbhd Code : Primary: SW.RU	Base Price : \$22,000
Nbhd Adj. %:	Total %Adjust :
Legal Acres: 5.15	Total \$Adjust :
5. Size - ACRS:	RMV Total : \$22,000
6. Size - SQFT:	14. Trend Adj % :
7. Eff. Front :	Trend RMV Tot : \$22,000
Eff. Depth :	
8. Unit Count :	
	Site Development
9. Situs Addr : (Not Applicable)	15. Exception Code :
	Value :
	16. BE Copy Trnd/Adj: No
10. Comments : 13-14: PER #73, CHG OSD FROM N TO F / 2012-13: ADD FULL WELL//	

'A'-Adjust	'R'-Recalc	'DEL'-Delete	'AL'-Allocate	'CM'-Comment
------------	------------	--------------	---------------	--------------

Enter selection, field #, or <RET> to Exit: __

R 335448

5/18/10 #yr ↑



TIMBER

FARMER

SECLUDED



F-29-13 R330748

1-29-13

BACK K9504A8



1-29-13 R530418





3-2-12 MA R 330448



R 000 118

10/16/06

MP

8x8

WELL ON RIGHT FOREGROUND



10/16/06

WELL

Assessor Monthly Issued Permit Report

For 3/1/2025 to 3/31/2025

PERMIT#: 555-25-001150-STR STATUS: Permit Issued
 PERMIT TYPE: Residential APPLIED: 2/18/2025
 SUB-TYPE: Structural ISSUED: 3/3/2025
 CATEGORY: Comprehensive EXPIRES: 8/30/2025

OFFICE: MC
 PARCEL#: 093W23A001900 R330448
 ACRES: 5.15
 SUBDIV: INDIAN WELLS ESTATES
 LOT/BLOCK: 8 & FR 3 /
 ADDRESS: 12174 TIMBER LN SE JEFFERSON, OR 97352

RELATIONSHIP	NAME	ADDRESS	PHONE
APPLICANT	SPIRES, TREVOR W & SPIRES, LISA D	12174 TIMBER LN SE JEFFERSON, OR 97352	503-507-9884
OWNER	SPIRES, TREVOR W & SPIRES, LISA D	12174 TIMBER LN SE JEFFERSON, OR 97352	
OWNER (PROPERTY)	SEE PROPERTY OWNER INFORMATION	OR	
SITE CONTACT	SPIRES, TREVOR W & SPIRES, LISA D	12174 TIMBER LN SE JEFFERSON, OR 97352	503-507-9884

CONST CAT: Detached Accessory Structure
 WORK TYPE: New
 WORK DESC: 48' x 36' POLE BARN, NO PLUMBING
 VALUATION: \$55,451.52
 STORIES: 0

BATHS:

KITCHENS:

SQUARE FEET

HABITABLE:

EXISTING: 0

NEW: 1728

TOTAL SQ. FT.: 1728

OCCUPANCY	CONSTRUCTION TYPE	SQ FT or # OF SPACES
U Utility, misc. - half rate	VB	1728 Sq Ft