

SKETCH/AREA TABLE ADDENDUM

SUBJECT INFO

File No.: 105466 Parcel No.: 081W34DB02900
 Property Address: 222 E MAIN ST
 City: SUBLIMITY County: Marion State: OR ZipCode: 97385
 Owner:
 Client: Client Address:
 Appraiser Name: Inspection Date:

SKETCH

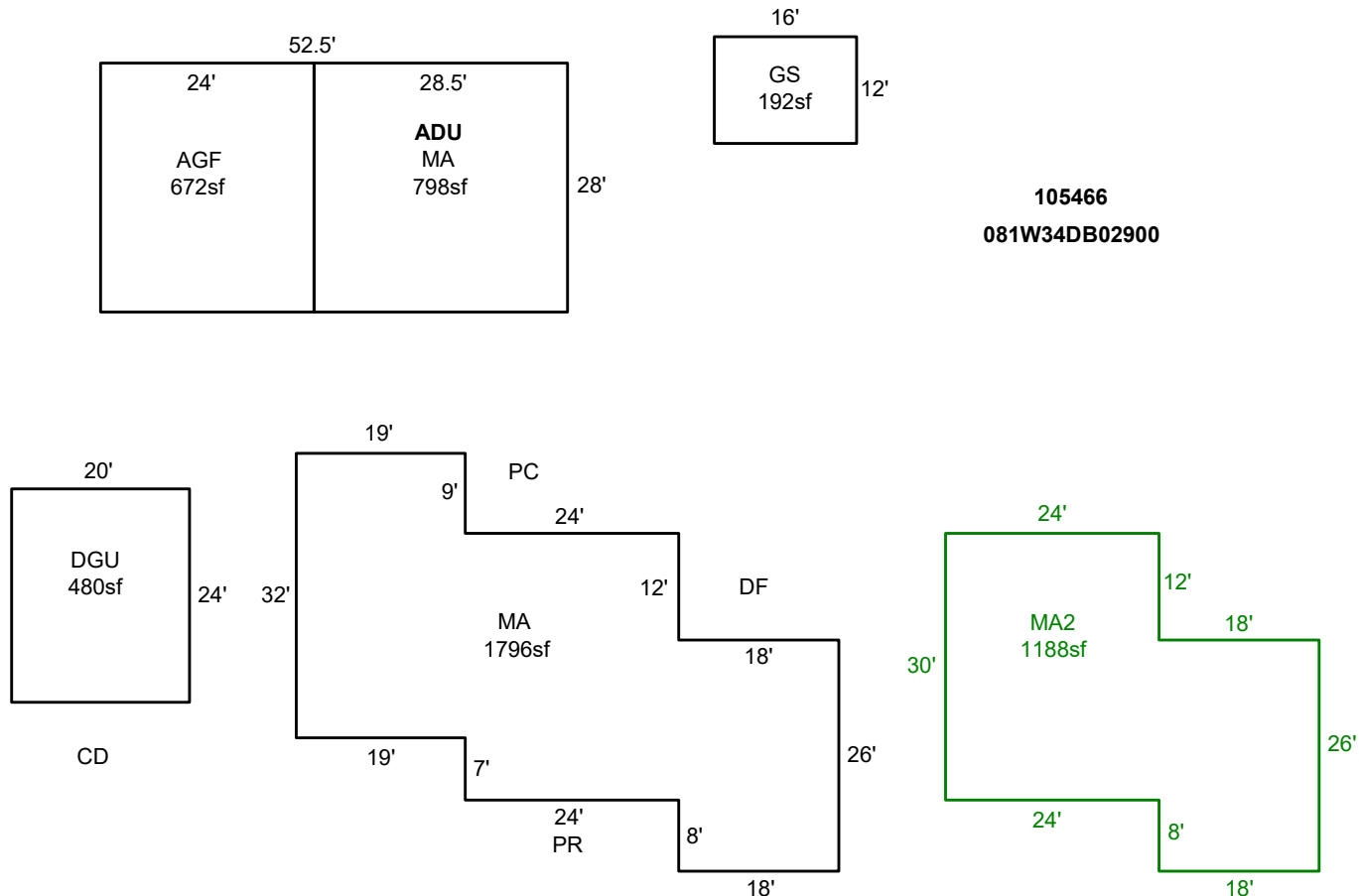

Sketch by ApexSketch

AREA CALCULATIONS SUMMARY

| Code | Description | Factor | Net Size | Perimeter | Net Totals |
|------|-------------|--------|----------|-----------|------------|
| GBA | GS | 1.0 | 192.0 | 56.0 | 192.0 |
| GLA | MA | 1.0 | 1796.0 | 216.0 | |
| | MA | 1.0 | 798.0 | 113.0 | 2594.0 |
| GLA2 | MA2 | 1.0 | 1188.0 | 160.0 | 1188.0 |
| GAR | DGU | 1.0 | 480.0 | 88.0 | |
| | AGF | 1.0 | 672.0 | 104.0 | 1152.0 |

COMMENT TABLE 1

Drawn by vwiegand 3/31/11
 Updated by AE 12.15.25

COMMENT TABLE 2

7/20/21 #72 Cycle

COMMENT TABLE 3

| | | | | | |
|--------------|-----|---|-----------|--|-------|
| Net LIVABLE | cnt | 3 | (rounded) | | 3,782 |
| Net BUILDING | cnt | 1 | (rounded) | | 192 |