

Acct ID: 534579 MTL: 091W11C001100 Date: 10-30-25 Appr: Anna Prop Class: 451 RMV Prop Class: 451
 Situs: 1513 PARK LN STAYTON OR 97383 MaSaNh: 01 06 000 Unit: 79509 Year: 2025
 Last Date Appraised: 08/30/2024 Appraiser: CLINT LUKE Tag: Y N Tag info: 2026 - REPAIR/REMODEL FRUSTRATED (Residence)
 Owner: SHEPHERDS CROSSING ON STATE LLC Last Sales Date: 01/05/2024 Roll Type: R
 Cycle: 0 Sales Verification Other: _____ Inspection level: 1 0 2 3 4 LCB TTO INSP AV: 115760
 RMV Land: 173630 RMV Imp: 53260 RMV Total: 226890 MAV: 32920 MSAV: 0 SAV: 0
 Comment: 25-26 L4 8/30/24 CLUKE

OSDs

NO CHANGES, APPEARS REMODEL HAS STARTED

Count	Code	Description	RMV	Code Area	Exception
2	MKTF	OSD - FAIR	40000	29540	19090

**RETRACT
10-1-26**

Land

Site: 2 Code Area: 29540 Size: 1.00 Acres Use Code: 005 Zone: UT SAV Use: Exception: 12540
 Class: 2BDSS Value Source: Rural Restrictive Description: TWO BENCH DRY SOUTH SPECIAL RMV: 26290 Exception: Y N
 Adjustment(s): WASTE, GSOIL Fire Patrol: Description:
 Comments: Liability year - 2009
 25-26: Disqual farm use
 25-26 SOIL VERIFIED WW

Site: 4 Code Area: 29540 Size: 1.00 Acres Use Code: 005 Zone: UT SAV Use: Exception: 12540
 Class: 2BDSS Value Source: Rural Restrictive Description: TWO BENCH DRY SOUTH SPECIAL RMV: 26290 Exception: Y N
 Adjustment(s): WASTE, GSOIL Fire Patrol: Description:
 Comments:

Site: 5 Code Area: 29540 Size: 1.52 Acres Use Code: 005 Zone: UT SAV Use: Exception: 19070
 Class: 2BDSS Value Source: Rural Restrictive Description: TWO BENCH DRY SOUTH SPECIAL RMV: 39970 Exception: Y N
 Adjustment(s): WASTE, GSOIL Fire Patrol: Description:
 Comments:

Site: 6 Code Area: 29540 Size: 0.56 Acres Use Code: 005 Zone: UT SAV Use: Exception: 190
 Class: WST Value Source: Market Wasteland Description: Rural WASTELAND RMV: 400 Exception: Y N
 Adjustment(s): WASTE, GSOIL Fire Patrol: Description:
 Comments:

Site: 7 Code Area: 29540 Size: 0.94 Acres Use Code: 005 Zone: UT SAV Use: Exception: 320
 Class: WST Value Source: MarketWater Description: Rural WASTELAND RMV: 680 Exception: Y N
 Adjustment(s): WASTE, GSOIL Fire Patrol: Description:
 Comments:

Improvements - Residence / Manufactured Structures

Bldg: 1 Code Area: 29540 Stat Class: 122 Year Blt: 1910 Eff Year Blt: 1910 Sq.Ft: 1531 % Complete: 55.00
 Desc: Multi Story above grade Dimensions: RMV: 43690
 Func Obsc: 100 Econ %: 100 Other %: 100 Exception: 0 Adjust: Adjust RMV: 0

Floors

Type	Class	Display Group	Floor Size	Beds	Baths	Yr Blt	Eff Yr Blt	Inventory	Exception
First Floor	2	Finished	1099	1	0	1910	1910	ROOF	Y N
Attic	2	Finished	432	2	0	1910	1910	HVAC	Y N

Accessories

Description	Class	Size SqFt	Eff Yr Blt	RMV	Quantity
No accessory data available					

Improvements - Accessory Buildings

Bldg: 2 Code Area: 29540 Stat Class: 351 Year Blt: 1971 Eff Year Blt: 1971 Sq.Ft: 1680 % Complete: 100.00
 Desc: General Purpose Building (GB) Dimensions: 42x40 RMV: 7000
 Func Obsc: 100 Econ %: 100 Other %: 100 Exception: 0 Adjust: Adjust RMV: 0

Floors

Type	Class	Display Group	Floor Size	Beds	Baths	Yr Blt	Eff Yr Blt	Inventory	Exception
General Purpose Bldg	5	Finished	1680	0	0	1971	1971	FAIR	Y N

Accessories

Description	Class	Size SqFt	Eff Yr Blt	RMV	Quantity
-------------	-------	-----------	------------	-----	----------

No accessory data available

Bldg: 3 Code Area: 29540 Stat Class: 354 Year Blt: 1971 Eff Year Blt: 1971 Sq.Ft: 936 % Complete: 100.00
 Desc: Lean-to Light (LTL) Dimensions: 36x26 RMV: 760
 Func Obsc: 100 Econ %: 100 Other %: 100 Exception: 0 Adjust: Adjust RMV: 0

Floors

Type	Class	Display Group	Floor Size	Beds	Baths	Yr Blt	Eff Yr Blt	Inventory
Lean-to Light Duty	4	Finished	936	0	0	1971	1971	Exception: Y N

Accessories

Description	Class	Size SqFt	Eff Yr Blt	RMV	Quantity
-------------	-------	-----------	------------	-----	----------

No accessory data available

Bldg: 4 Code Area: 29540 Stat Class: 354 Year Blt: 1971 Eff Year Blt: 1971 Sq.Ft: 528 % Complete: 100.00
 Desc: Lean-to Light (LTL) Dimensions: 44x12 RMV: 430
 Func Obsc: 100 Econ %: 100 Other %: 100 Exception: 0 Adjust: Adjust RMV: 0

Floors

Type	Class	Display Group	Floor Size	Beds	Baths	Yr Blt	Eff Yr Blt	Inventory
Lean-to Light Duty	4	Finished	528	0	0	1971	1971	Exception: Y N

Accessories

Description	Class	Size SqFt	Eff Yr Blt	RMV	Quantity
-------------	-------	-----------	------------	-----	----------

No accessory data available

Bldg: 5 Code Area: 29540 Stat Class: 354 Year Blt: Eff Year Blt: 1999 Sq.Ft: 680 % Complete: 100.00
 Desc: Lean-to Light (LTL) Dimensions: 34x20 RMV: 1380
 Func Obsc: 100 Econ %: 100 Other %: 100 Exception: 0 Adjust: Adjust RMV: 0

Floors

Type	Class	Display Group	Floor Size	Beds	Baths	Yr Blt	Eff Yr Blt	Inventory
Lean-to Light Duty	4	Finished	680	0	0	0	1999	Exception: Y N

Accessories

Description	Class	Size SqFt	Eff Yr Blt	RMV	Quantity
-------------	-------	-----------	------------	-----	----------

No accessory data available

Farm Notes

2024FARM

11/19/24: Inspected by CWO L4 unable to determine farm use, send inquiry letter 11/20/24.

2025FARM

25-26: CL inspected L3 on 7-14-25, grass very tall, no animals, proceed w/disqual.



10/30/25

SKETCH/AREA TABLE ADDENDUM

Parcel No 091W11C 01100

File No R34579

SUBJECT	Property Address 1513 Park Ln	State OR	Zip 9738
	City Stayton		
	Owner		
	Client		
	Appraiser Name		

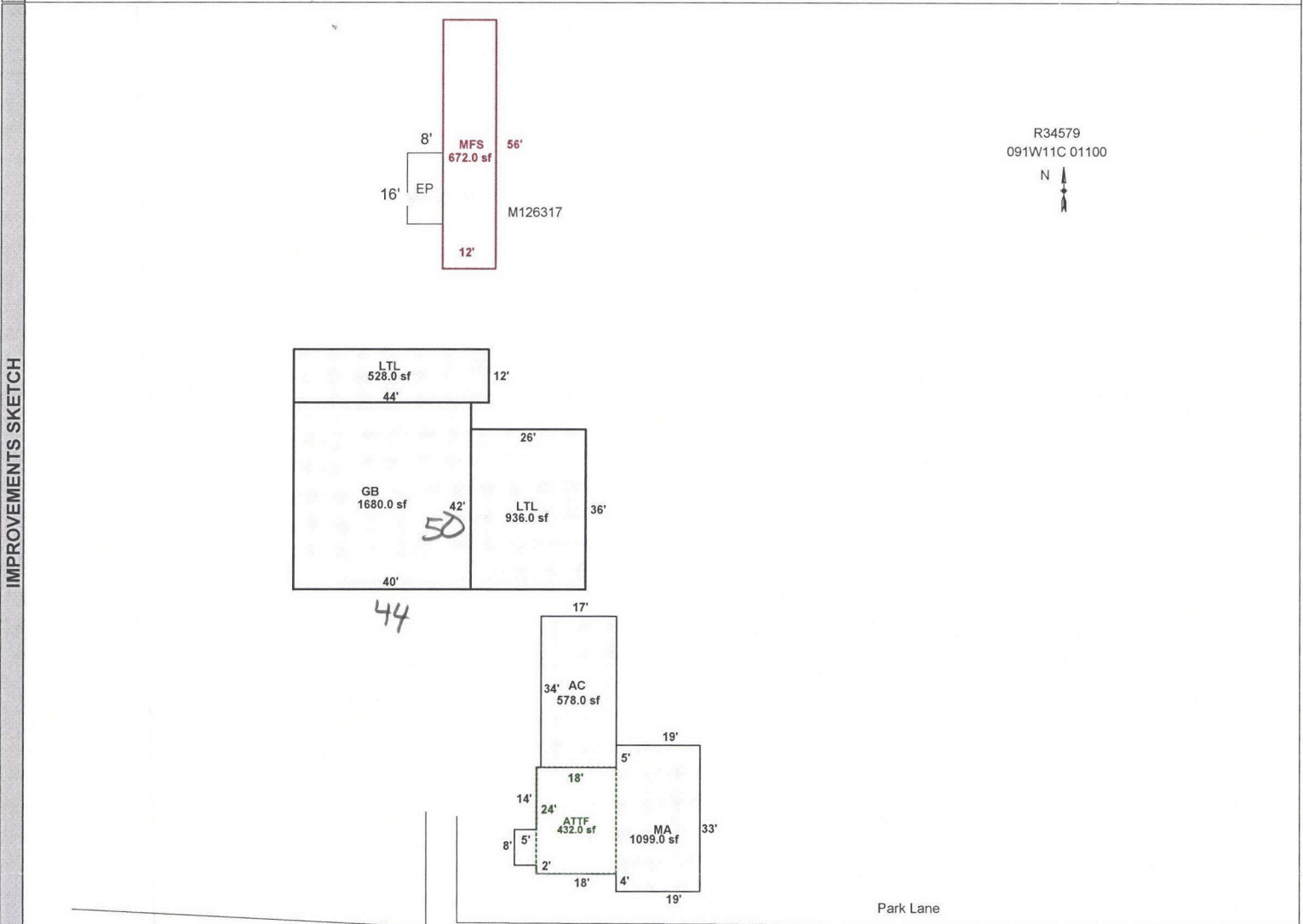

AREA CALCULATIONS	AREA CALCULATIONS SUMMARY						Comment Table 1	
	Code	Description	Factor	Net Size	Perimeter	Net Totals	Apex 9/10/2012 Jane	
	GLA1	MA	1.00	1099.0	150.0			
		MFS	1.00	672.0	136.0	1771.0		
	GLA2	ATTF	1.00	432.0	84.0	432.0		
	GBA1	GB	1.00	1680.0	164.0			
		LTL	1.00	936.0	124.0			
		LTL	1.00	528.0	112.0	3144.0		
	GAR	AC	1.00	578.0	102.0	578.0		
	P/P	EP	1.00	128.0	48.0	128.0		
	Net LIVABLE Area		(rounded w/ factors)		2203			
	Net BUILDING Area		(rounded w/ factors)		3144			
	Comment Table 2		Comment Table 3					