

# SKETCH/AREA TABLE ADDENDUM

## SUBJECT INFO

File No.: 609889 Parcel No.: 051W06DB00700  
 Property Address: 808 Magnolia Ave  
 City: Woodburn County: Marion State: OR ZipCode: 97071  
 Owner:  
 Client:  
 Appraiser Name: Inspection Date:

## SKETCH

**609889**  
**051W06DB0700**

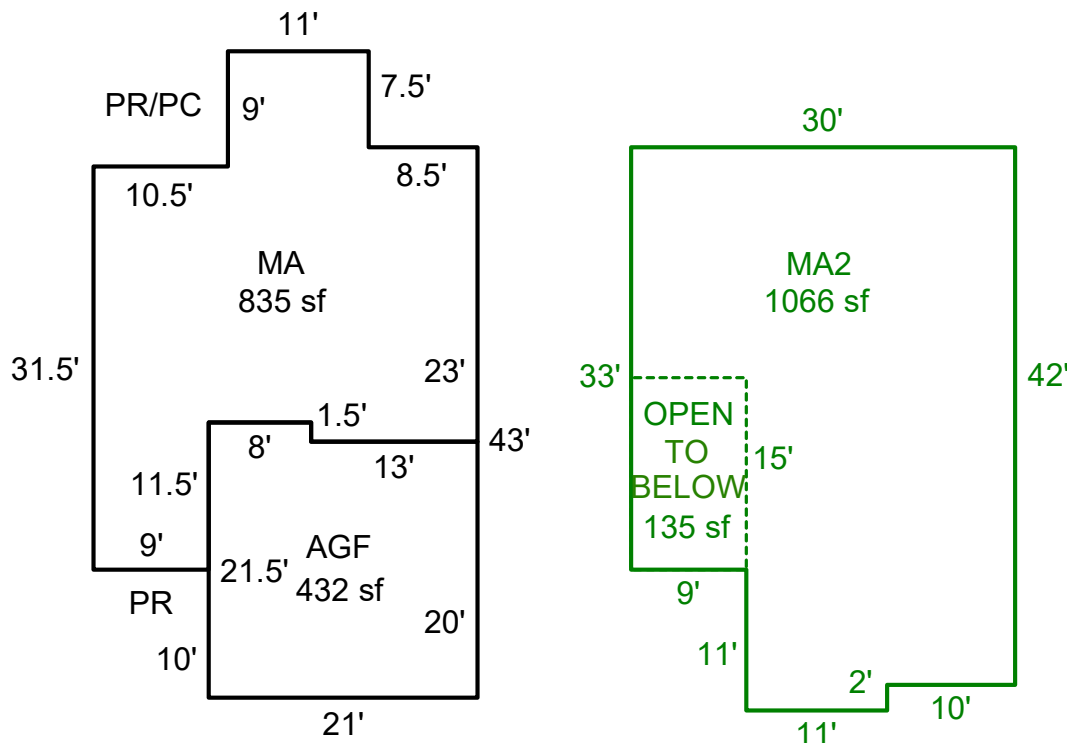

Sketch by ApexSketch

AREA CALCULATIONS SUMMARY						COMMENT TABLE 1		
Code	Description	Factor	Net Size	Perimeter	Net Totals	Drawn by AE 11.25.25		
GLA	MA	1.0	834.8	144.0	834.8			
GLA2	MA2	1.0	1066.0	148.0	1066.0			
GAR	AGF	1.0	432.0	85.0	432.0			
OTH	OPEN	1.0	135.0	48.0	135.0			
Net LIVABLE						cnt	2 (rounded)	1,901
						COMMENT TABLE 2	COMMENT TABLE 3	