

Acct ID: 540369 MTL: 091E050001200 Date: 8-26-25 Appr: LUKE Prop Class: 551 RMV Prop Class: 551  
 Situs: 17182 FERN RIDGE RD SE STAYTON OR 97383 MaSaNh: 01 06 000 Unit: 74759 Year: 2025  
 Last Date Appraised: 10/10/2012 Appraiser: CLINT LUKE Retag: Y N Tag info: \_\_\_\_\_  
 Owner: KING, CLAIRE E & KING, JERRY G Roll Type: R  
Cycl Tag Sales Verification Other: \_\_\_\_\_ Inspection level: 1 2 3 4 LCB TTO INSP AV: 634482  
 RMV Land: 526420 RMV Imp: 894520 RMV Total: 1420940 MAV: 605860 MSAV: 28622 SAV: 51052  
 Comment: \_\_\_\_\_

INPUT  
 9-8-25  
 GWA

**Notations**

RP/MS	Code	Description
RP	ZONED	FARM EFU ZONED

**OSDs**

Count	Code	Description	RMV	Code Area	Exception
2	SAG	SA OSD - GOOD	60000	29540	0

**Land**

CHRISTINA TRUSS/BOUGHT BUSINESS

Site: 2 Code Area: 29540 Size: 1.00 Acres Use Code: 005 Zone: REST SAV Use: 011 Exception: 0  
 Class: Value Source: Farm Homesite Description: RMV: 43290 Exception: Y N  
 Adjustment(s): VWAR Fire Patrol: SA004 Description: FIRE PATROL  
 Comments: Liability year - 2009 / 2900040

Site: 3 Code Area: 29540 Size: 12.67 Acres Use Code: 005 Zone: REST SAV Use: 011 Exception: 0  
 Class: 4HD Value Source: Farm Use - EFU Description: FOUR HILL DRY RMV: 295050 Exception: Y N  
 Adjustment(s): VWAR Fire Patrol: SA004 Description: FIRE PATROL  
 Comments: Liability year - 1980 / 2900040: 01-02; CHANGED SOIL CLASS FROM 3 HILL DRY TO 4 HILL DRY, COMBINED LAND SEGS, SAME SOIL CLASS, SAME LIAB YEAR, 11.16 ACRES TOTAL

Site: 4 Code Area: 29540 Size: 5.50 Acres Use Code: 005 Zone: REST SAV Use: 011 Exception: 0  
 Class: WOOD D Value Source: Woodlot Description: FARM WOODLOT RMV: 128080 Exception: Y N  
 Adjustment(s): VWAR Fire Patrol: SA004 Description: FIRE PATROL  
 Comments: Liability year - 1980 / 02900000//2013-14: SALES VERIF BY #36- CHG WASTELAND-M TO WOODLOT-M AND 4HILL DRY//08-09: Market wasteland study by GW39 - change from wasteland to wasteland-M//01-02; UPDATED MARKET VALUE /02-03: REAPPRAISAL 08-09: CORRECTED PART TOTALS

**Improvements - Residence / Manufactured Structures**

Bldg: 1 Code Area: 29540 Stat Class: 164 - Year Blt: 1978 Eff Year Blt: 1978 Sq.Ft: 5001 % Complete: 100  
 Desc: Multi Story above grade with basement Dimensions: RMV: 747230  
 Func Obsc: 100 Econ %: 100 Other %: 100 Exception: 0 Adjust: Adjust RMV: 0

**Floors**

Type	Class	Display Group	Floor Size	Beds	Baths	Yr Blt	Eff Yr Blt	Inventory	Exception
First Floor	6 -	Finished	2208	4	FB-2	1978	1978	HVAC, KIT, FP - 2, ROOF, BATH - 2	Y N
Second Floor	6 -	Finished	1123	0	FB-2	1978	1978	BATH - 2, HVAC	Y N
Basement	6 -	Finished	555	0	FB-1/ HB-1	1978	1978	HVAC, BTH - 1	Y N
Basement	6 -	Low Cost	1115	0	0	1978	1978		Y N

AV  
AVB

**Accessories**

Description	Class	Size SqFt	Eff Yr Blt	RMV	Quantity	Exception
CONCRETE DRIVEWAY	6	525	1978	1314	1	Y N
DECK	6	428	2006	8569	1	Y N
DECK	6	540	2006	9828	1	Y N

V16A

Bldg: 2 Code Area: 29540 Stat Class: 148 Year Blt: 1981 Eff Year Blt: 1981 Sq.Ft: 0 % Complete: 100  
 Desc: Res other improvements Dimensions: RMV: 64470  
 Func Obsc: 100 Econ %: 100 Other %: 100 Exception: 0 Adjust: Adjust RMV: 0

**Floors**

Type	Class	Display Group	Floor Size	Beds	Baths	Yr Blt	Eff Yr Blt	Inventory	Exception
Garage Detached	4	Unfinished	840	0	0	1981	1981	ROOF	Y N

AVB

**Accessories**

Description	Class	Size SqFt	Eff Yr Blt	RMV	Quantity
No accessory data available					

Bldg: 3 Code Area: 29540 Stat Class: 108 Year Blt: 1981 Eff Year Blt: 1981 Sq.Ft: 0 % Complete: 100

Desc: Residential Other Improvements

Dimensions:

RMV: 50300

Func Obsc: 100

Econ %: 100

Other %: 100

Exception: 0

Adjust:

Adjust RMV: 0

Floors

Type	Class	Display Group	Floor Size	Beds	Baths	Yr Blt	Eff Yr Blt	Inventory
------	-------	---------------	------------	------	-------	--------	------------	-----------

No floor data available

NK

Accessories

Description	Class	Size SqFt	Eff Yr Blt	RMV	Quantity
ASPHALT DRIVEWAY	1	25470	1981	50303	1

Improvements - Accessory Buildings

Bldg: 4 Code Area: 29540 Stat Class: 351 Year Blt: 1989 Eff Year Blt: 1989 Sq.Ft: 1440 % Complete: 100  
 Desc: General Purpose Building (GB) Dimensions: 48x30 RMV: 9310  
 Func Obsc: 100 Econ %: 100 Other %: 100 Exception: 0 Adjust: 6° Adjust RMV: 0

Floors

Type	Class	Display Group	Floor Size	Beds	Baths	Yr Blt	Eff Yr Blt	Inventory
General Purpose Bldg	5	Finished	1440	0	0	1989	1989	EXR

OUR MISTAKE

60%  
NB

⓪

Accessories

Description	Class	Size SqFt	Eff Yr Blt	RMV	Quantity
-------------	-------	-----------	------------	-----	----------

No accessory data available

Bldg: 5 Code Area: 29540 Stat Class: 351 Year Blt: 1998 Eff Year Blt: 1998 Sq.Ft: 1056 % Complete: 100  
 Desc: General Purpose Building (GB) Dimensions: 44x24 RMV: 17730  
 Func Obsc: 100 Econ %: 100 Other %: 100 Exception: 0 Adjust: Adjust RMV: 0

Floors

Type	Class	Display Group	Floor Size	Beds	Baths	Yr Blt	Eff Yr Blt	Inventory
General Purpose Bldg	6	Finished	1056	0	FB-1	1998	1998	AVG, LOFT, BATH - 1

60%  
1056

⓪

Accessories

Description	Class	Size SqFt	Eff Yr Blt	RMV	Quantity
-------------	-------	-----------	------------	-----	----------

No accessory data available

Bldg: 6 Code Area: 29540 Stat Class: 356 Year Blt: 1998 Eff Year Blt: 1998 Sq.Ft: 528 % Complete: 100  
 Desc: Lean-to Excellent (LTE) Dimensions: 12x44 RMV: 2740  
 Func Obsc: 100 Econ %: 100 Other %: 100 Exception: 0 Adjust: Adjust RMV: 0

Floors

Type	Class	Display Group	Floor Size	Beds	Baths	Yr Blt	Eff Yr Blt	Inventory
Lean-to Excellent	4	Finished	528	0	0	1998	1998	

60%

Y N

Accessories

Description	Class	Size SqFt	Eff Yr Blt	RMV	Quantity
-------------	-------	-----------	------------	-----	----------

No accessory data available

Bldg: 7 Code Area: 29540 Stat Class: 356 Year Blt: 1998 Eff Year Blt: 1998 Sq.Ft: 528 % Complete: 100  
 Desc: Lean-to Excellent (LTE) Dimensions: RMV: 2740  
 Func Obsc: 100 Econ %: 100 Other %: 100 Exception: 0 Adjust: Adjust RMV: 0

Floors

Type	Class	Display Group	Floor Size	Beds	Baths	Yr Blt	Eff Yr Blt	Inventory
Lean-to Excellent	4	Finished	528	0	0	1998	1998	

60%

Y N

Accessories

Description	Class	Size SqFt	Eff Yr Blt	RMV	Quantity
-------------	-------	-----------	------------	-----	----------

No accessory data available

# SKETCH/AREA TABLE ADDENDUM

Parcel No 091E 05 01200

File No R40369

SUBJECT	Property Address <b>17182 Fern Ridge Rd SE</b>	State <b>OR</b>	Zip <b>97383</b>
	City <b>Stayton</b>		
	Owner		
	Client		
	Appraiser Name		

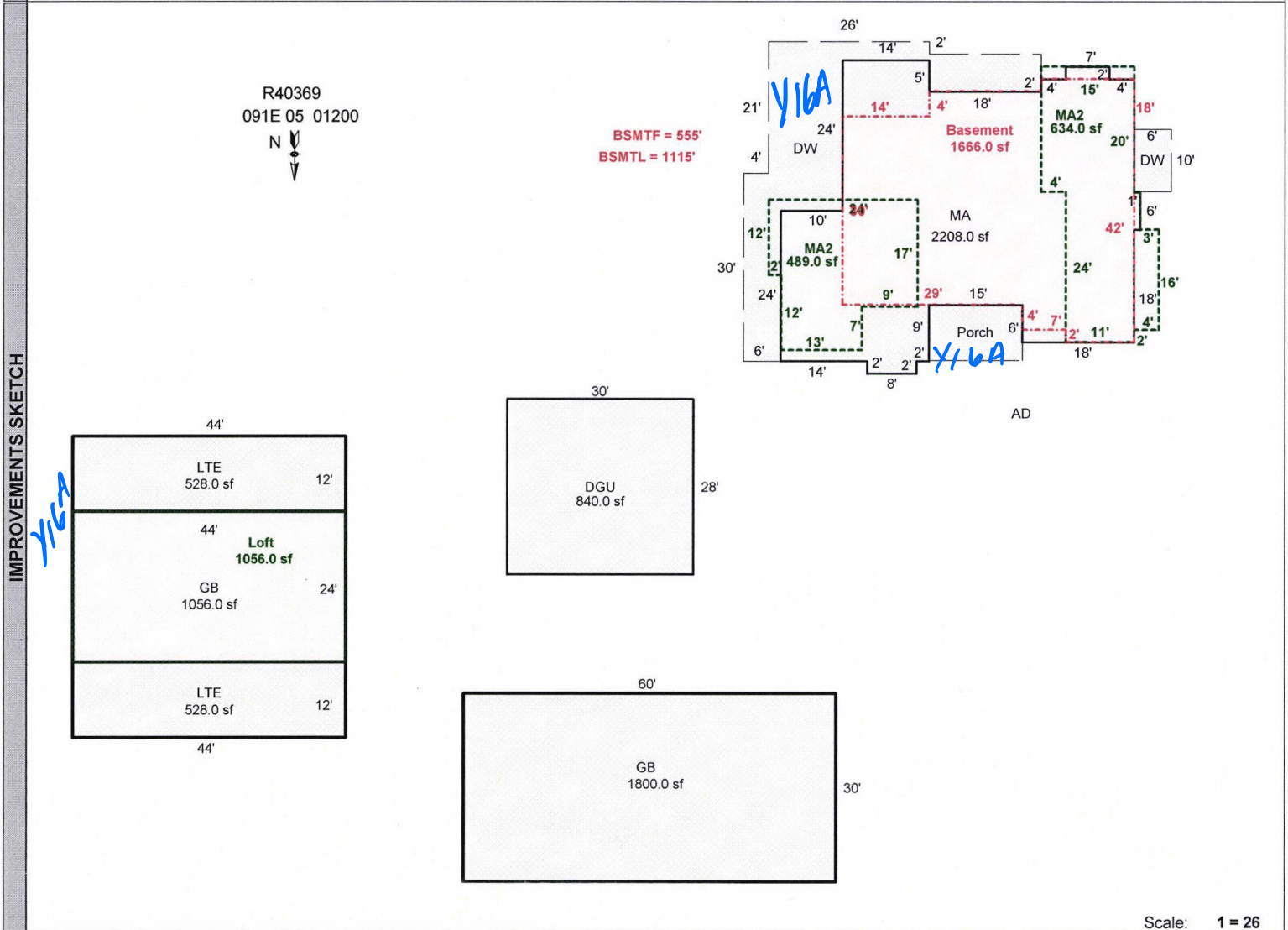

Scale: 1 = 26

AREA CALCULATIONS	AREA CALCULATIONS SUMMARY					
	Code	Description	Factor	Net Size	Perimeter	Net Totals
	GLA1	MA	1.00	2208.0	236.0	2208.0
	GLA2	MA2	1.00	489.0	96.0	
		MA2	1.00	634.0	126.0	1123.0
	GBA1	GB	1.00	1800.0	180.0	
		GB	1.00	1056.0	136.0	
		LTE	1.00	528.0	112.0	
		LTE	1.00	528.0	112.0	3912.0
	BSMT	Basement	1.00	1666.0	178.0	1666.0
GAR	DGU	1.00	840.0	116.0	840.0	
P/P	Porch	1.00	135.0	48.0		
	DW	1.00	60.0	32.0		
	DW	1.00	642.0	208.0	837.0	
OTH	Loft	1.00	1056.0	136.0	1056.0	
	Net LIVABLE Area		(rounded w/ factors)		3331	
	Net BUILDING Area		(rounded w/ factors)		3912	

Comment Table 1	
Apex 10/16/2012 Jane	
Comment Table 2	Comment Table 3
<p style="font-size: 2em; color: blue; transform: rotate(-15deg);">                     Date 8-26-25                      C90814                 </p>	