

Summary Lead Appr: _____ Clerk: _____ Lead Clerk: _____ Appr: MDL Input 5/16/25 Print Date: 1/25/2024

Acct ID: 537298 MTL: 103W120000200 Date: 4/3/25 Appr: MDL Prop Class: 551 RMV Prop Class: 551
Situs: 3375 CEMETERY HILL RD SE JEFFERSON OR 97352 MaSaNh: 07 06 000 Unit: 89949 Year: 2024 2025
Last Date Appraised: 02/11/2022 Appraiser: MATT LORD Retag: Y N Tag info:
Owner: STAM, WILLIAM L SR Roll Type: R
Cycle Tag Sales Verification Other: _____ Inspection level: 1 2 3 4 LCB TTO INSP AV: 231406
RMV Land: 286820 RMV Imp: 326250 RMV Total: 613070 MAV: 190900 MSAV: 40506 SAV: 88062
Comment: 22-23: L4 02.11.22 MHamilton Gated

Notations 25-26 cycle

RP/MS	Code	Description
RP	ZONED	FARM EFU ZONED

OSDs

Count	Code	Description	RMV	Code Area	Exception
1	SAA	SA OSD - AVERAGE	45000	14530	0

Land

Site: 1 Code Area: 14530 Size: 1.00 Acres Use Code: 005 Zone: REST SAV Use: 011 Exception: 0
Class: 2HD Value Source: Farm Homesite Description: TWO HILL DRY RMV: 80610 Exception: Y N
Adjustment(s): GSOIL Fire Patrol: Description:
Comments: Liability year - 2014 / 14-15: PER #73 & #58 ROLL FROM DFL TO FARM USE// 03-04: REAPPRAISAL

Site: 3 Code Area: 14530 Size: 1.30 Acres Use Code: 005 Zone: REST SAV Use: 011 Exception: 0
Class: 2HD Value Source: Woodlot Description: TWO HILL DRY RMV: 104790 Exception: Y N
Adjustment(s): GSOIL Fire Patrol: Description:
Comments: Liability year - 1986

Site: 4 Code Area: 14530 Size: 0.70 Acres Use Code: 005 Zone: REST SAV Use: 011 Exception: 0
Class: 2HD Value Source: Farm Use - EFU Description: TWO HILL DRY RMV: 56420 Exception: Y N
Adjustment(s): GSOIL Fire Patrol: Description:
Comments: Liability year - 1986

Improvements - Residence / Manufactured Structures

Bldg: 1 Code Area: 14530 Stat Class: 141 Year Blt: 1977 Eff Year Blt: 1989 Sq.Ft: 2772 % Complete: 100
Desc: One Story Only Dimensions: RMV: 311390
Func Obsc: 100 Econ %: 100 Other %: 100 Exception: 0 Adjust: Adjust RMV: 0

Floors

Type	Class	Display Group	Floor Size	Beds	Baths	Yr Blt	Eff Yr Blt	Inventory	Exception
First Floor	4	Finished	2772	3	FB-1	1977	1989	KIT-, HVAC+, ROOF, BATH - 1	Y N

Accessories

Description	Class	Size SqFt	Eff Yr Blt	RMV	Quantity	Exception
ASPHALT DRIVEWAY	4	8600	1989	17845	0	Y N
DECK	4	658	1989	10923	1	Y N
ROOF EXTENSION OR PATIO COVER	4	115	1989	2768	0	Y N

Bldg: 10 Code Area: 14530 Stat Class: 108 Year Blt: Eff Year Blt: 1989 Sq.Ft: 0 % Complete: 100
Desc: Residential Other Improvements Dimensions: RMV: 1350
Func Obsc: 100 Econ %: 100 Other %: 100 Exception: 0 Adjust: Adjust RMV: 0

Floors

Type	Class	Display Group	Floor Size	Beds	Baths	Yr Blt	Eff Yr Blt	Inventory
No floor data available								

Accessories

Description	Class	Size SqFt	Eff Yr Blt	RMV	Quantity	Exception
DECK	1	32	1989	584	0	Y N
ROOF EXTENSION OR PATIO COVER	1	32	1989	770	0	Y N

Improvements - Accessory Buildings

Bldg: 2 Code Area: 14530 Stat Class: 341 Year Blt: Eff Year Blt: Sq.Ft: 64 % Complete: 100
Desc: Multi Purpose Shed (MP) Dimensions: 8x8 RMV: 0
Func Obsc: 0 Econ %: 100 Other %: 100 Exception: 0 Adjust: Adjust RMV: 0

Floors

Type	Class	Display Group	Floor Size	Beds	Baths	Yr Blt	Eff Yr Blt	Inventory	
Multi-Purpose Bldg	4	Finished	64	0	0	0	0	FAIR	Exception: Y N

Accessories

Description	Class	Size SqFt	Eff Yr Blt	RMV	Quantity
No accessory data available					

Bldg: 3	Code Area: 14530	Stat Class: 351	Year Blt: 1977	Eff Year Blt: 1977	Sq.Ft: 2160	% Complete: 100
Desc: General Purpose Building (GB)			Dimensions: 90x24		RMV: 6270	
Func Obsc: 100	Econ %: 100	Other %: 100	Exception: 0	Adjust:	Adjust RMV: 0	

Floors

Type	Class	Display Group	Floor Size	Beds	Baths	Yr Blt	Eff Yr Blt	Inventory	
General Purpose Bldg	4	Finished	2160	0	0	1977	1977	FAIR ✓	Exception: Y N

Accessories

Description	Class	Size SqFt	Eff Yr Blt	RMV	Quantity
No accessory data available					

Bldg: 4	Code Area: 14530	Stat Class: 351	Year Blt: 1977	Eff Year Blt: 1977	Sq.Ft: 1200	% Complete: 100
Desc: General Purpose Building (GB)			Dimensions: 40x30		RMV: 3020	
Func Obsc: 100	Econ %: 100	Other %: 100	Exception: 0	Adjust:	Adjust RMV: 0	

Floors

Type	Class	Display Group	Floor Size	Beds	Baths	Yr Blt	Eff Yr Blt	Inventory	
General Purpose Bldg	4	Finished	1200	0	0	1977	1977	FAIR	Exception: Y N

Accessories

Description	Class	Size SqFt	Eff Yr Blt	RMV	Quantity
No accessory data available					

Bldg: 5	Code Area: 14530	Stat Class: 341	Year Blt: 1977	Eff Year Blt: 1977	Sq.Ft: 288	% Complete: 100
Desc: Multi Purpose Shed (MP)			Dimensions: 24x12		RMV: 1020	
Func Obsc: 100	Econ %: 100	Other %: 100	Exception: 0	Adjust:	Adjust RMV: 0	

Floors

Type	Class	Display Group	Floor Size	Beds	Baths	Yr Blt	Eff Yr Blt	Inventory	
Multi-Purpose Bldg	4	Finished	288	0	0	1977	1977	FAIR	Exception: Y N

Accessories

Description	Class	Size SqFt	Eff Yr Blt	RMV	Quantity
No accessory data available					

Bldg: 7	Code Area: 14530	Stat Class: 321	Year Blt:	Eff Year Blt: 1989	Sq.Ft: 240	% Complete: 100
Desc: Hay Cover (HC)			Dimensions: 20x12		RMV: 580	
Func Obsc: 100	Econ %: 100	Other %: 100	Exception: 0	Adjust:	Adjust RMV: 0	

Floors

Type	Class	Display Group	Floor Size	Beds	Baths	Yr Blt	Eff Yr Blt	Inventory	
Hay Cover	5	Finished	240	0	0	0	1989	FAIR	Exception: Y N

Accessories

Description	Class	Size SqFt	Eff Yr Blt	RMV	Quantity
No accessory data available					

Bldg: 8	Code Area: 14530	Stat Class: 341	Year Blt:	Eff Year Blt: 1989	Sq.Ft: 192	% Complete: 100
Desc: Multi Purpose Shed (MP)			Dimensions: 16x12		RMV: 1200	
Func Obsc: 100	Econ %: 100	Other %: 100	Exception: 0	Adjust:	Adjust RMV: 0	

Floors

Type	Class	Display Group	Floor Size	Beds	Baths	Yr Blt	Eff Yr Blt	Inventory	
Multi-Purpose Bldg	4	Finished	192	0	0	0	1989	FAIR	Exception: Y N

Accessories

Description	Class	Size SqFt	Eff Yr Blt	RMV	Quantity
No accessory data available					

Bldg: 9	Code Area: 14530	Stat Class: 341	Year Blt:	Eff Year Blt: 1989	Sq.Ft: 192	% Complete: 100
Desc: Multi Purpose Shed (MP)			Dimensions: 16x12		RMV: 1420	
Func Obsc: 100	Econ %: 100	Other %: 100	Exception: 0	Adjust:	Adjust RMV: 0	

Floors

Type	Class	Display Group	Floor Size	Beds	Baths	Yr Blt	Eff Yr Blt	Inventory	Exception: Y N
Multi-Purpose Bldg	5	Finished	192	0	0	0	1989	FAIR	

Accessories

Description	Class	Size SqFt	Eff Yr Blt	RMV	Quantity
No accessory data available					

SKETCH/AREA TABLE ADDENDUM

SUBJECT INFO

File No.: 537298 Parcel No.: 103W12 00200
 Property Address: 3375 Cemetery Hill Rd SE
 City: Jefferson County: State: OR ZipCode: 97352
 Owner:
 Client: Client Address:
 Appraiser Name: Inspection Date:

SKETCH

537298
103W12 00200
1=30'

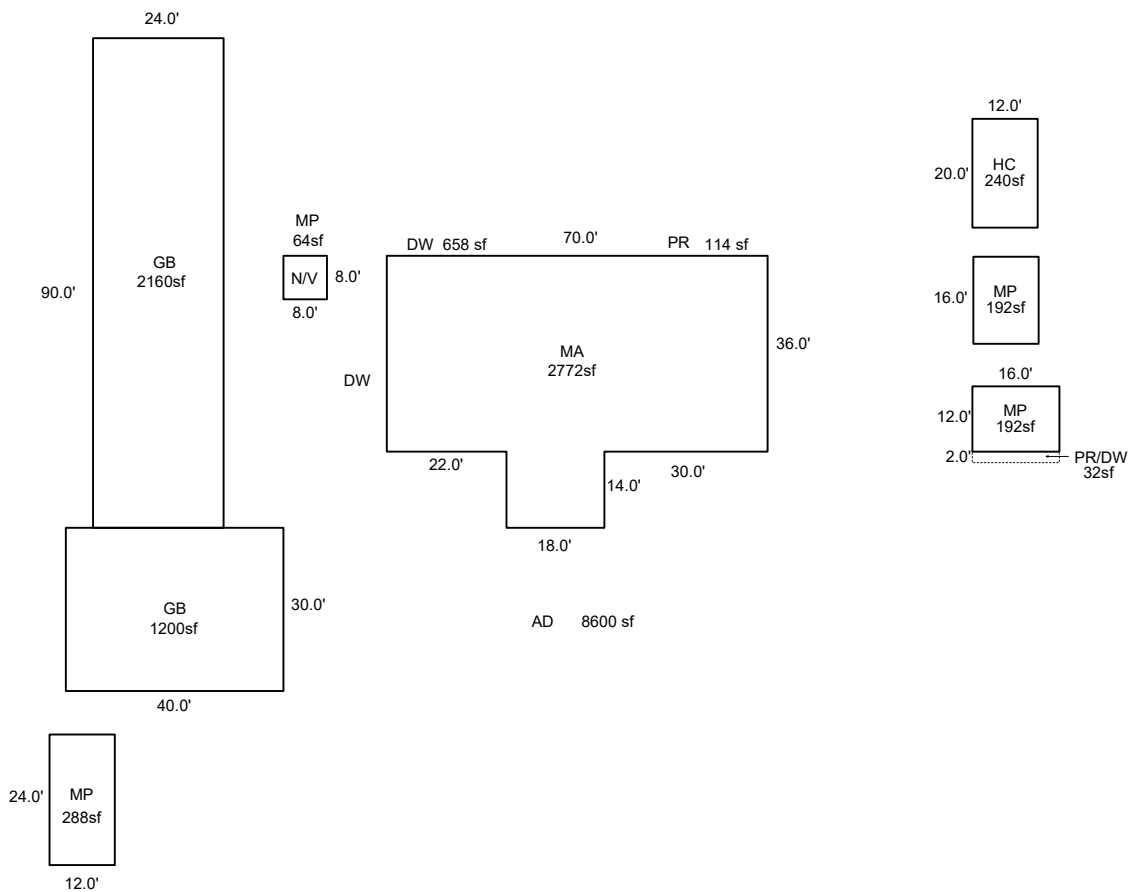

Sketch by ApexSketch

AREA CALCULATIONS SUMMARY

Code	Description	Factor	Net Size	Perimeter	Net Totals
GBA1	MP	1.0	64.0	32.0	
	GB	1.0	2160.0	228.0	
	GB	1.0	1200.0	140.0	
	MP	1.0	288.0	72.0	
	HC	1.0	240.0	64.0	
	MP	1.0	192.0	56.0	
	MP	1.0	192.0	56.0	4336.0
GLA1	MA	1.0	2772.0	240.0	2772.0
P/P	PR/DW	1.0	32.0	36.0	32.0
	Net LIVABLE	cnt	0 (rounded)		2,772
	Net BUILDING	cnt	7 (rounded)		4,336

COMMENT TABLE 1

Apex by RW 04/28/08
 UPDATED BY CLOBERG 09/23/25

COMMENT TABLE 2

MDL 04/03/25

COMMENT TABLE 3

CYCLE L4

SKETCH/AREA TABLE ADDENDUM

Parcel No 103W12 00200

File No R37298

Property Address 3375 Cemetery Hill Rd SE

City Jefferson

State OR

Zip 97352

Owner

Client

Appraiser Name

SUBJECT

IMPROVEMENTS SKETCH

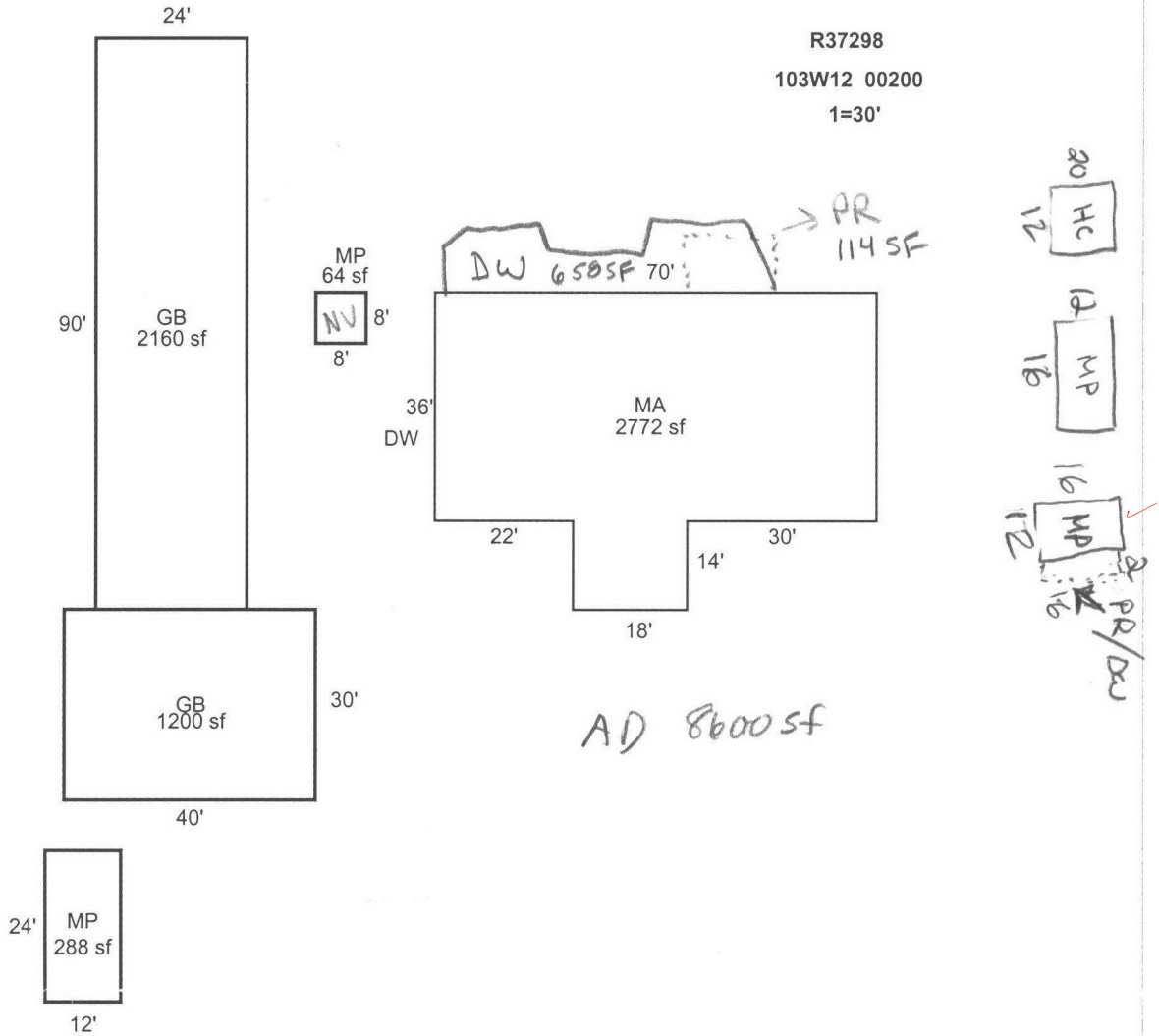

AREA CALCULATIONS

AREA CALCULATIONS SUMMARY

Code	Description	Factor	Net Size	Perimeter	Net Totals
GLA1	MA	1.00	2772	240	2772
GBA1	MP	1.00	64	32	
	GB	1.00	2160	228	3712
	GB	1.00	1200	140	
	MP	1.00	288	72	

Comment Table 1

Apex by RW 04/28/08

Comment Table 2

749 2/11/22

Comment Table 3

Cycle L4

Net LIVABLE Area
Net BUILDING Area

(Rounded w/ Factors)
(Rounded w/ Factors)

2772
3712