

Acct ID: 534933 MTL: 091W190002000 Date: **4/22/25** Appr: **MLH** Prop Class: 551 RMV Prop Class: 451
 Situs: 9242 SANTIAM LOOP SE AUMSVILLE OR 97325 MaSaNh: 07 06 000 Unit: 83544 Year: 2025
 Last Date Appraised: 11/07/2023 Appraiser: MATT LORD Retag: Y N Tag info: 2024 - Tags/Permit (Addition)
 Owner: MENDEZ, MARGARET Roll Type: R
 Cycle Tag Sales Verification Other: Clean Up Inspection level: 1 2 3 4 LCB TTO INSP AV: 102596
 RMV Land: 428270 RMV Imp: 171469 RMV Total: 599739 MAV: 64830 MSAV: 37766 SAV: 80464
 Comment: 24-25: L2 MDL 11.7.23 TAG

Notations *Update Inventory* *Input MLH 7/24/25*
Farm seed

RP/MS	Code	Description
MS	ZONED	FARM EFU ZONED
MS	ZONED	FARM EFU ZONED

OSDs

Count	Code	Description	RMV	Code Area	Exception
1	SAF	SA OSD - FAIR	40000	05545	0

Land

Site: 2 Code Area: 05545 Size: 1.00 Acres Use Code: 005 Zone: REST SAV Use: 011 Exception: 0
 Class: 2BISS Value Source: Farm Homesite Description: TWO BENCH IRR SOUTH SPECIAL RMV: 29810 Exception: Y N
 Adjustment(s): GSOIL, IRR Fire Patrol: Description:
 Comments: Liability year - 2009 / 550040

Site: 3 Code Area: 05545 Size: 11.50 Acres Use Code: 005 Zone: REST SAV Use: 011 Exception: 0
 Class: 2BISS Value Source: Farm Use - EFU Description: TWO BENCH IRR SOUTH SPECIAL RMV: 358460 Exception: Y N
 Adjustment(s): GSOIL, IRR Fire Patrol: Description:
 Comments: Liability year - 1980 / 550040

Improvements - Residence / Manufactured Structures

Bldg: 1 Code Area: 05545 Stat Class: 124 Year Blt: 1910 Eff Year Blt: 1919 Sq.Ft: 2642 % Complete: 100
 Desc: Multi Story above grade with basement Dimensions: RMV: 166344
 Func Obsc: 100 Econ %: 100 Other %: 100 Exception: 0 Adjust: Adjust RMV: 0 *I/O*

Floors

Type	Class	Display Group	Floor Size	Beds	Baths	Yr Blt	Eff Yr Blt	Inventory	Exception
First Floor	2	Finished	1802	1	FB-1	1910	1919	HVAC, ROOF, BATH - 1, KIT+	Exception: Y N
Second Floor	2	Finished	360	2	0	1910	1919	HVAC	Exception: Y N
Second Floor	2	Finished	480	0	0	1910	1919	<i>HVAC</i>	Exception: Y N
Basement	2	Unfinished	360	0	0	1919	1919		Exception: Y N
Garage Attached	2	Unfinished	576	0	0	1910	1913	ROOF	Exception: Y N

Accessories

Description	Class	Size SqFt	Eff Yr Blt	RMV	Quantity	Exception
GARDEN GREENHOUSE <i>delete</i>	2	200	1919	4154 <i>Conversion error</i>	1	Exception: Y N
YARD IMPROVEMENTS AVERAGE <i>Good</i>	2	0	1919	5564	1	Exception: Y N

Bldg: 6 Code Area: 05545 Stat Class: 108 Year Blt: 2006 Eff Year Blt: 2006 Sq.Ft: 0 % Complete: 100
 Desc: Residential Other Improvements Dimensions: RMV: 1500
 Func Obsc: 100 Econ %: 100 Other %: 100 Exception: 0 Adjust: Adjust RMV: 0

Floors

Type	Class	Display Group	Floor Size	Beds	Baths	Yr Blt	Eff Yr Blt	Inventory
No floor data available								

Accessories

Description	Class	Size SqFt	Eff Yr Blt	RMV	Quantity	Exception
GAZEBO <i>Part of YI Move MAV</i>	1	77	2006	1500	1	Exception: Y N

Improvements - Accessory Buildings

Bldg: 4 Code Area: 05545 Stat Class: 351 Year Blt: 1971 Eff Year Blt: 1971 Sq.Ft: 1185 % Complete: 100
 Desc: General Purpose Building (GB) Dimensions: ~~4028~~ RMV: 3625
 Func Obsc: 100 Econ %: 100 Other %: 100 Exception: 0 Adjust: Adjust RMV: 0 *N/C*

Floors

Type	Class	Display Group	Floor Size	Beds	Baths	Yr Blt	Eff Yr Blt	Inventory	Exception: Y N
General Purpose Bldg	4	Finished	1185	0	0	1971	1971	FAIR	

Accessories

Description	Class	Size SqFt	Eff Yr Blt	RMV	Quantity
No accessory data available					

Bldg: 5 Code Area: 05545 Stat Class: 301 Year Blt: Eff Year Blt: Sq.Ft: 0 % Complete: 100
 Desc: Accessory Improvements & Misc. Dimensions: 12x12 RMV: 0
 Func Obsc: 100 Econ %: 100 Other %: 100 Exception: 0 Adjust: Adjust RMV: 0

Floors *old sheds change to MP 4 NU*

Type	Class	Display Group	Floor Size	Beds	Baths	Yr Blt	Eff Yr Blt	Inventory	Exception: Y N
Building Structure	0	Finished	0	0	0	0	0		

Accessories

Description	Class	Size SqFt	Eff Yr Blt	RMV	Quantity
No accessory data available					

SKETCH/AREA TABLE ADDENDUM

SUBJECT INFO

File No.: 534933 Parcel No.: 091W19 02000
 Property Address: 9242 SANTIAM LOOP SE
 City: AUMSVILLE County: MARION State: OR ZipCode: 97325
 Owner:
 Client: Client Address:
 Appraiser Name: Inspection Date:

SKETCH

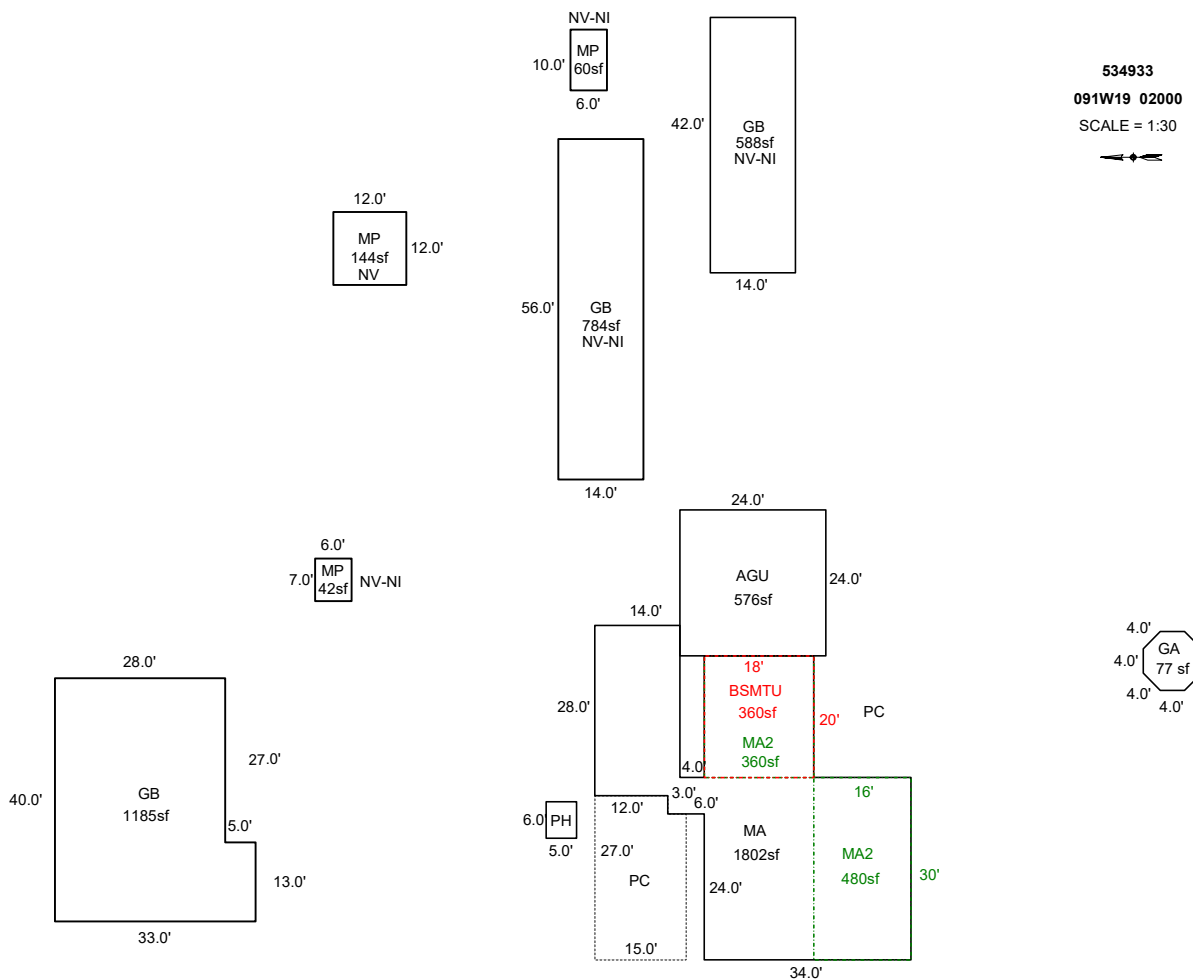

AREA CALCULATIONS SUMMARY

Code	Description	Factor	Net Size	Perimeter	Net Totals
GBA1	PH	1.0	30.0	22.0	
	MP	1.0	42.0	26.0	
	GB	1.0	784.0	140.0	
	MP	1.0	144.0	48.0	
	GB	1.0	588.0	112.0	
	MP	1.0	60.0	32.0	
	GB	1.0	1185.0	146.0	2833.0
GLA1	MA	1.0	1802.0	254.0	1802.0
GLA2	MA2	1.0	480.0	92.0	
	MA2	1.0	360.0	76.0	840.0
BSMT	BSMTU	1.0	360.0	76.0	360.0
GAR	AGU	1.0	576.0	96.0	576.0
OTH	GA	1.0	77.3	32.0	77.3
P/P	Patio	1.0	396.0	84.0	396.0
	Net LIVABLE	cnt	0 (rounded)		2,642
	Net BUILDING	cnt	7 (rounded)		2,833

COMMENT TABLE 1

Apex 12/07/2010 Jane
 UPDATED BY SRAGSDALE 10/23/14
 UPDATED BY CJURAN 01/17/2023 555-22-010999
 UPDATED BY WW 4.24.24
 UPDATED BY CLOBERG 07/23/25
 UPDATED BY CLOBERG 09/19/25

COMMENT TABLE 2

MDL 11.7.23
 MLH 06/10/25

COMMENT TABLE 3

TAGS L2
 CLEAN UP L4

SKETCH/AREA TABLE ADDENDUM

SUBJECT INFO

File No.: 534933 Parcel No.: 091W19 02000
 Property Address: 9242 SANTIAM LOOP SE
 City: AUMSVILLE County: MARION State: OR ZipCode: 97325
 Owner:
 Client: Client Address:
 Appraiser Name: Inspection Date:

SKETCH

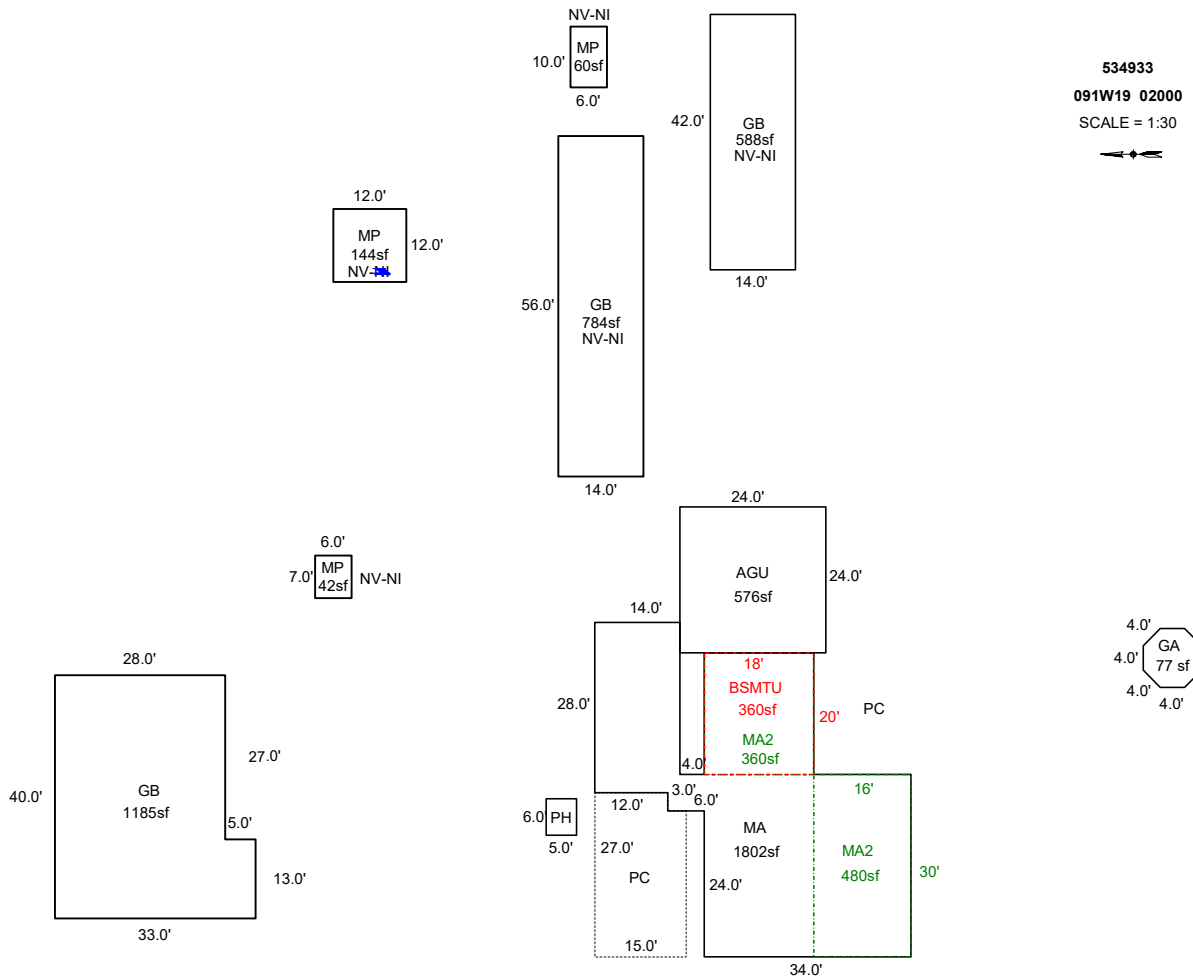

AREA CALCULATIONS SUMMARY

Code	Description	Factor	Net Size	Perimeter	Net Totals
GBA1	PH	1.0	30.0	22.0	
	MP	1.0	42.0	26.0	
	GB	1.0	784.0	140.0	
	MP	1.0	144.0	48.0	
	GB	1.0	588.0	112.0	
	MP	1.0	60.0	32.0	
	GB	1.0	1185.0	146.0	2833.0
GLA1	MA	1.0	1802.0	254.0	1802.0
GLA2	MA2	1.0	480.0	92.0	
	MA2	1.0	360.0	76.0	840.0
BSMT	BSMTU	1.0	360.0	76.0	360.0
GAR	AGU	1.0	576.0	96.0	576.0
OTH	GA	1.0	77.3	32.0	77.3
P/P	Patio	1.0	396.0	84.0	396.0
	Net LIVABLE	cnt	0 (rounded)		2,642
	Net BUILDING	cnt	7 (rounded)		2,833

COMMENT TABLE 1

Apex 12/07/2010 Jane
 UPDATED BY SRAGSDALE 10/23/14
 UPDATED BY CJURAN 01/17/2023 555-22-010999
 UPDATED BY WW 4.24.24
 UPDATED BY CLOBERG 07/23/25

COMMENT TABLE 2

MDL 11.7.23
 MLH 06/10/25

COMMENT TABLE 3

TAGS L2
 CLEAN UP L4

SKETCH/AREA TABLE ADDENDUM

SUBJECT INFO

File No.: 534933 Parcel No.: 091W19 02000
 Property Address: 9242 SANTIAM LOOP SE
 City: AUMSVILLE County: MARION State: OR ZipCode: 97325
 Owner:
 Client: Client Address:
 Appraiser Name: Inspection Date:

SKETCH

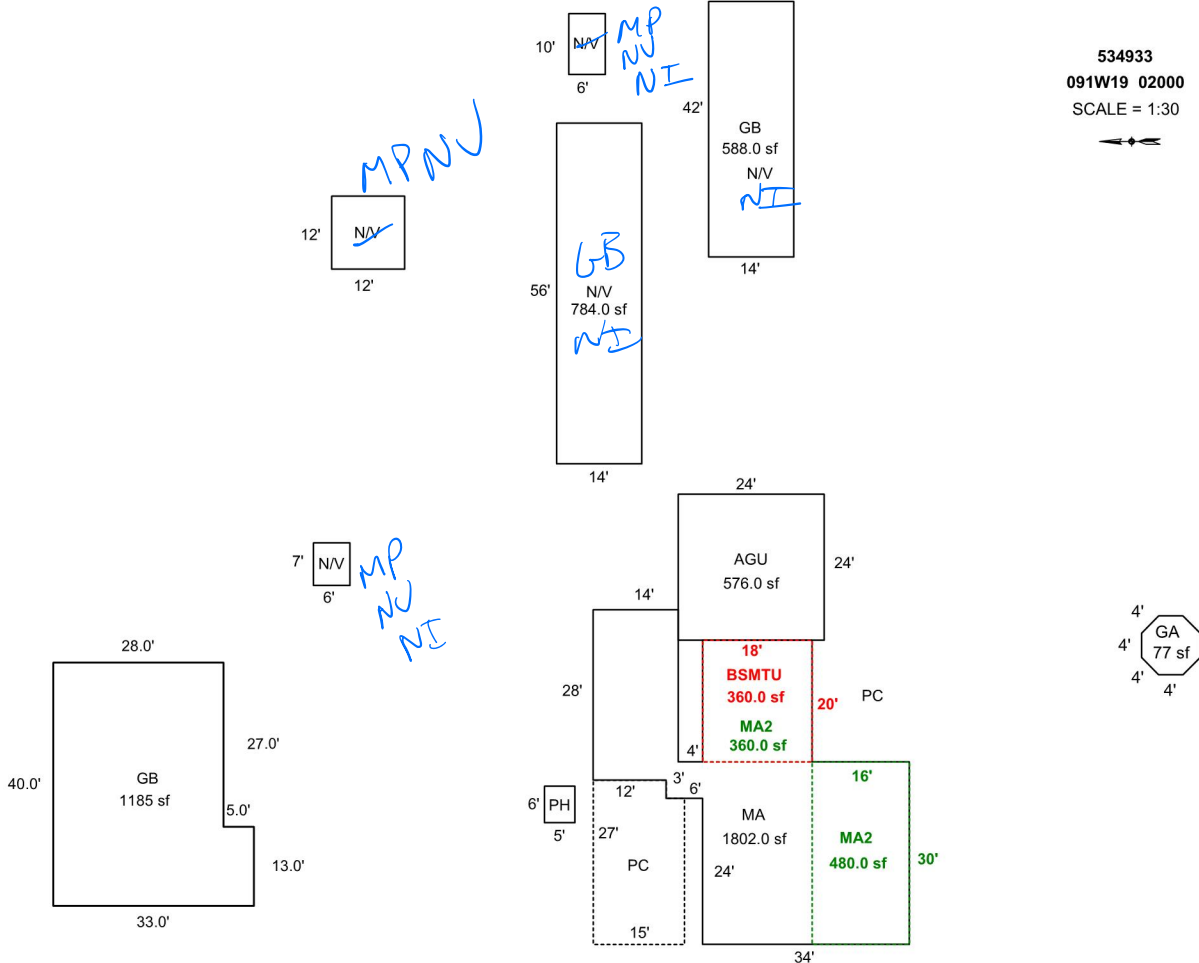

Sketch by ApexSketch

AREA CALCULATIONS SUMMARY

Code	Description	Factor	Net Size	Perimeter	Net Totals
GBA1	PH	1.0	30.0	22.0	
	N/V	1.0	42.0	26.0	
	N/V	1.0	784.0	140.0	
	N/V	1.0	144.0	48.0	
	GB	1.0	588.0	112.0	
	N/V	1.0	60.0	32.0	
	GB	1.0	1185.0	146.0	2833.0
GLA1	MA	1.0	1802.0	254.0	1802.0
GLA2	MA2	1.0	480.0	92.0	
	MA2	1.0	360.0	76.0	840.0
BSMT	BSMTU	1.0	360.0	76.0	360.0
GAR	AGU	1.0	576.0	96.0	576.0
OTH	GA	1.0	77.3	32.0	77.3
P/P	Patio	1.0	396.0	84.0	396.0
	Net LIVABLE	cnt	3 (rounded)		2,642
	Net BUILDING	cnt	7 (rounded)		2,833

COMMENT TABLE 1

Apex 12/07/2010 Jane
 UPDATED BY SRAGSDALE 10/23/14
 UPDATED BY CJURAN 01/17/2023 555-22-010999
 UPDATED BY WW 4.24.24

COMMENT TABLE 2

MDL 11.7.23
6/10/25 MLT

COMMENT TABLE 3

TAGS L2
Clean up LY

