

Acct ID: 533258 MTL: 083W30A001200 Date: \_\_\_\_\_ Appr: **GPH** Prop Class: 641 RMV Prop Class: 401  
 Situs: 7442 MOORE RD S SALEM OR 97306 MaSaNh: 06 06 000 Unit: 60597 Year: 2025

Last Date Appraised: 10/03/2024 Appraiser: GERARDO RAMIREZ HERNANDEZ Retag: **Y** N Tag info: 2025 - Tags/Permit (Alt Energy System)  
*tag for next year 5/1/26*

Owner: ADKINS, JOSHUA & ADKINS, TESSA Roll Type: R  
 Cycle Tag Sales Verification Other: **Forest check** Inspection level: 1 **2** 3 4 LCB TTO INSP AV: 217001  
 RMV Land: 326530 RMV Imp: 356190 RMV Total: 682720 MAV: 215570 MSAV: 1431 SAV: 2775  
 Comment: 25-26: L4 10.03.24 WW

**Notations**

*Check Next year per chris*

RP/MS	Code	Description
RP	411	SEE ACCOUNT NOTES - 411
RP	DFL	DESIGNATED FORESTLAND

**OSDs**

Count	Code	Description	RMV	Code Area	Exception
1	MKTF	OSD - FAIR	40000	92430	0

**Land**

Site: 1 Code Area: 92430 Size: 1.00 Acres Use Code: 005 Zone: REST SAV Use: Exception: 0  
 Class: 4HD Value Source: Market Homesite Description: FOUR HILL DRY RMV: 71100 Exception: Y N  
 Adjustment(s): Fire Patrol: Description:  
 Comments: 25-26 ADD SOIL

20-21: #35 C19 CYCLE WORK, NO CHG / 00-01; 2400230, UPDATE MARKET VALUE /01-02; REAPPRAISAL

Site: 2 Code Area: 92430 Size: 2.50 Acres Use Code: 005 Zone: REST SAV Use: 011 Exception: 0  
 Class: FTLC Value Source: Designated Forest Land Description: DFL Class C RMV: 177750 Exception: Y N  
 Adjustment(s): Fire Patrol: Description:  
 Comments: Liability year - 1997 / 00-01; 2400230, UPDATE MARKET VALUE /01-02; REAPPRAISAL

Site: 3 Code Area: 92430 Size: 0.53 Acres Use Code: 005 Zone: REST SAV Use: Exception: 0  
 Class: 4HD Value Source: Rural Restrictive Description: FOUR HILL DRY RMV: 37680 Exception: Y N  
 Adjustment(s): Fire Patrol: Description:  
 Comments: 25-26 ADD SOIL 00-01; 2400230, UPDATE MARKET VALUE /01-02; REAPPRAISAL

**Improvements - Residence / Manufactured Structures**

Bldg: 1 Code Area: 92430 Stat Class: 142 Year Blt: 1920 Eff Year Blt: 1968 Sq.Ft: 1864 % Complete: 100  
 Desc: Multi Story above grade Dimensions: RMV: 253150  
 Func Obsc: 100 Econ %: 100 Other %: 100 Exception: 0 Adjust: Adjust RMV: 0

**Floors**

Type	Class	Display Group	Floor Size	Beds	Baths	Yr Blt	Eff Yr Blt	Inventory	Exception
First Floor	4	Finished	1577	4	FB-2	1920	1968	ROOF, FP - 1, HVAC, KIT-, BATH - 2	Y N
Second Floor	4	Finished	287	0	0	1920	1968	HVAC	Y N

**Accessories**

Description	Class	Size SqFt	Eff Yr Blt	RMV	Quantity
YARD IMPROVEMENTS GOOD	4	0	1968	30816	1

Bldg: 4 Code Area: 92430 Stat Class: 148 Year Blt: 1997 Eff Year Blt: 1997 Sq.Ft: 0 % Complete: 100  
 Desc: Res other improvements Dimensions: RMV: 77970  
 Func Obsc: 100 Econ %: 100 Other %: 100 Exception: 0 Adjust: Adjust RMV: 0

**Floors**

Type	Class	Display Group	Floor Size	Beds	Baths	Yr Blt	Eff Yr Blt	Inventory	Exception
Garage Detached	4	Unfinished	936	0	0	1997	1997	ROOF	Y N

**Accessories**

Description	Class	Size SqFt	Eff Yr Blt	RMV	Quantity
No accessory data available					

**Improvements - Accessory Buildings**

Bldg: 2 Code Area: 92430 Stat Class: 351 Year Blt: 1930 Eff Year Blt: 1960 Sq.Ft: 520 % Complete: 100  
 Desc: General Purpose Building (GB) Dimensions: 26x20 RMV: 1690  
 Func Obsc: 100 Econ %: 100 Other %: 100 Exception: 0 Adjust: Adjust RMV: 0

**Floors**

Type	Class	Display Group	Floor Size	Beds	Baths	Yr Blt	Eff Yr Blt	Inventory	
General Purpose Bldg	4	Finished	520	0	0	1930	1960	FAIR	Exception: Y N

**Accessories**

Description	Class	Size SqFt	Eff Yr Blt	RMV	Quantity
No accessory data available					

Bldg: 3	Code Area: 92430	Stat Class: 341	Year Blt: 1997	Eff Year Blt: 1997	Sq.Ft: 128	% Complete: 100
Desc: Multi Purpose Shed (MP)			Dimensions: 16x8			RMV: 3200
Func Obsc: 100	Econ %: 100	Other %: 100	Exception: 0	Adjust:	Adjust RMV: 0	

**Floors**

Type	Class	Display Group	Floor Size	Beds	Baths	Yr Blt	Eff Yr Blt	Inventory	
Multi-Purpose Bldg	6	Finished	128	0	0	1997	1997	AVG	Exception: Y N

**Accessories**

Description	Class	Size SqFt	Eff Yr Blt	RMV	Quantity
No accessory data available					

Bldg: 5	Code Area: 92430	Stat Class: 355	Year Blt: 1960	Eff Year Blt: 1960	Sq.Ft: 130	% Complete: 100
Desc: Lean-to Heavy (LTH)			Dimensions: 5x26			RMV: 180
Func Obsc: 100	Econ %: 100	Other %: 100	Exception: 0	Adjust:	Adjust RMV: 0	

**Floors**

Type	Class	Display Group	Floor Size	Beds	Baths	Yr Blt	Eff Yr Blt	Inventory	
Lean-to Heavy Duty	4	Finished	130	0	0	1960	1960		Exception: Y N

**Accessories**

Description	Class	Size SqFt	Eff Yr Blt	RMV	Quantity
No accessory data available					

Bldg: 6	Code Area: 92430	Stat Class: 905	Year Blt: 2024	Eff Year Blt: 2024	Sq.Ft: 0	% Complete: 100
Desc: Rural Solar Panel/Array			Dimensions:			RMV: 20000
Func Obsc: 100	Econ %: 100	Other %: 100	Exception: 0	Adjust:	Adjust RMV: 0	

**Floors**

Type	Class	Display Group	Floor Size	Beds	Baths	Yr Blt	Eff Yr Blt	Inventory	
No floor data available									

**Accessories**

Description	Class	Size SqFt	Eff Yr Blt	RMV	Quantity
No accessory data available					

# SKETCH/AREA TABLE ADDENDUM

Parcel No **083W30A 01200**

File No **R33258**

SUBJECT

Property Address **7442 MOORE RD S**

City **SALEM**

State **OR**

Zip **97306**

Owner

Client

Appraiser Name

IMPROVEMENTS SKETCH

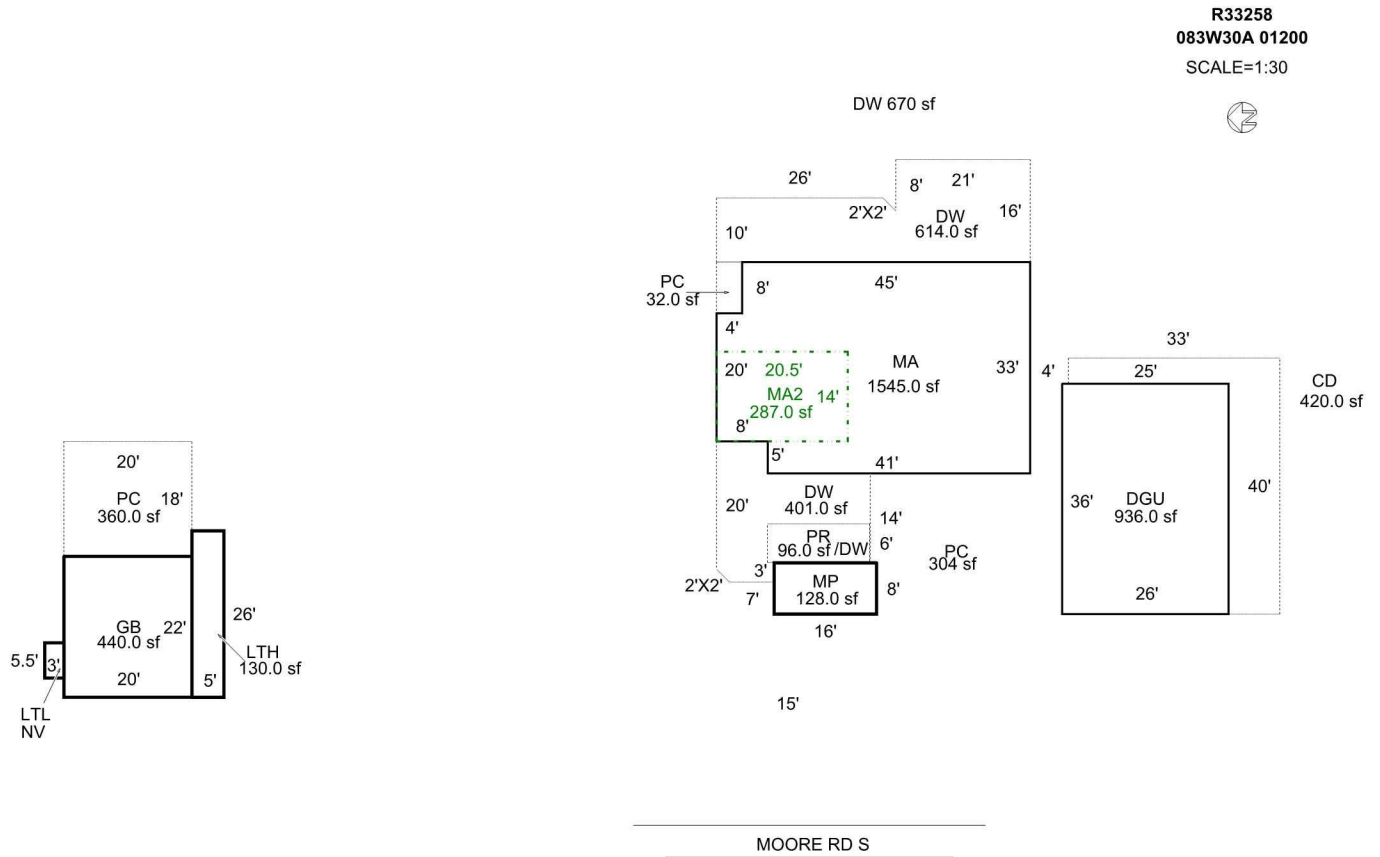

Scale: **1" = 30'**

AREA CALCULATIONS

### AREA CALCULATIONS SUMMARY

Code	Description	Factor	Net Size	Perimeter	Net Totals
GLA1	MA	1.00	1545.00	164.0	1545.00
GLA2	MA2	1.00	287.00	69.0	287.00
GBA1	MP	1.00	128.00	48.0	
	GB	1.00	440.00	84.0	
	LTH	1.00	130.00	62.0	
	LTL	1.00	16.50	17.0	714.50
GARG	DGU	1.00	936.00	124.0	936.00
YI1	PR	1.00	96.00	44.0	
	DW	1.00	401.00	90.8	
	PC	1.00	32.00	24.0	
	PC	1.00	360.00	76.0	889.00
Net LIVABLE Area (rounded w/ factors)					1832
Net BUILDING Area (rounded w/ factors)					715

#### Comment Table 1

APEXED BY NRC 04/20/2009  
UPD BY PH 04.15.20

#### Comment Table 2

04.04.19 NM #35

#### Comment Table 3

S.V.