

SKETCH/AREA TABLE ADDENDUM

SUBJECT INFO

File No.: 101559 Parcel No.: 061E22AB03900
 Property Address: 698 GRAND VIEW AVE
 City: SCOTTS MILLS County: Marion State: OR ZipCode: 97375
 Owner:
 Client: Client Address:
 Appraiser Name: Inspection Date:

SKETCH

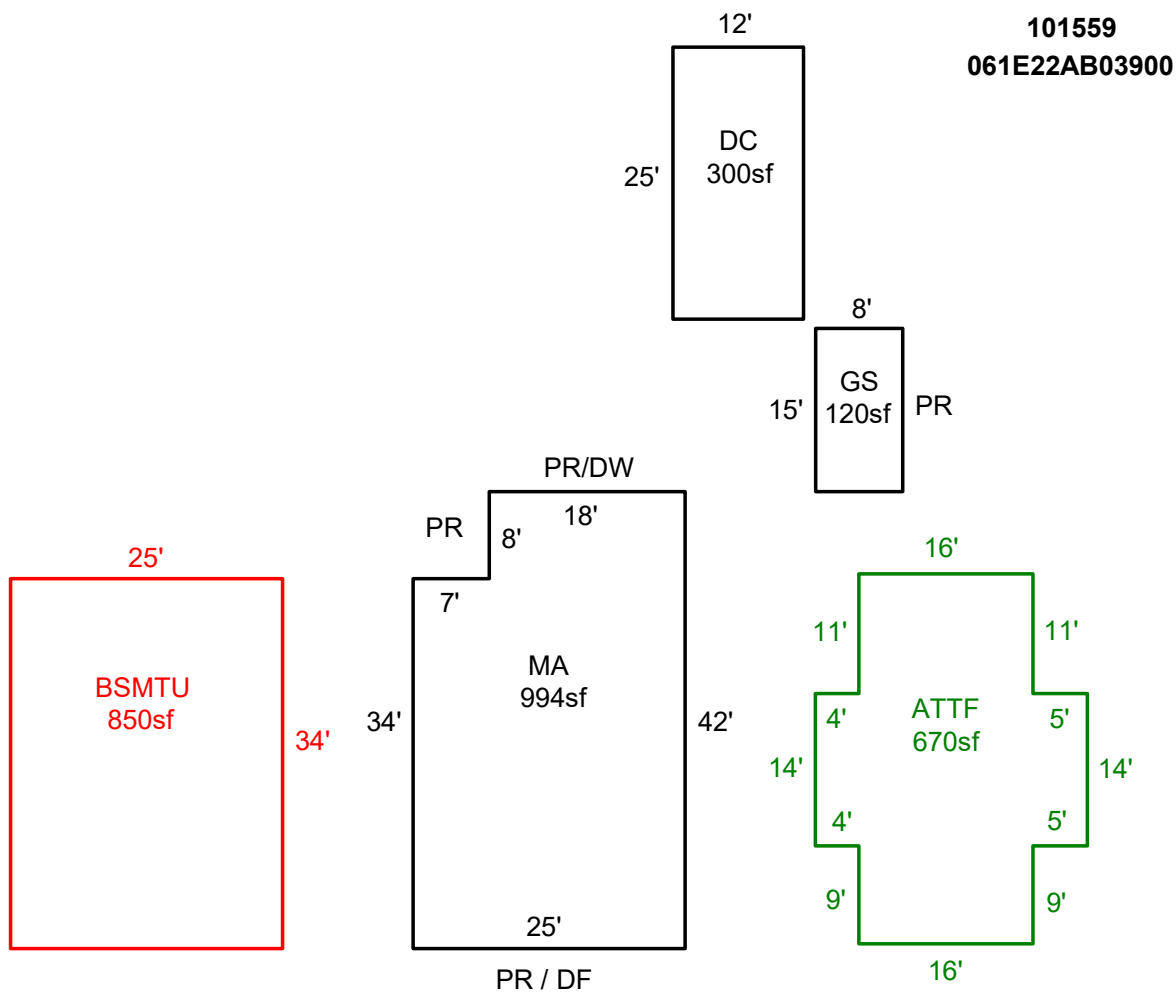

Sketch by ApexSketch

AREA CALCULATIONS SUMMARY

Code	Description	Factor	Net Size	Perimeter	Net Totals
GBA	GS	1.0	120.0	46.0	120.0
GLA	MA	1.0	994.0	134.0	994.0
GLA2	ATTF	1.0	670.0	118.0	670.0
BSMT	BSMTU	1.0	850.0	118.0	850.0
GAR	DC	1.0	300.0	74.0	300.0

COMMENT TABLE 1

APEX BY MJB 04-15-10
 UPDATED BY LK 8.25.25

COMMENT TABLE 2

8.19.25 OTHER VE AG

COMMENT TABLE 3

Net LIVABLE	cnt	2	(rounded)	1,664
Net BUILDING	cnt	1	(rounded)	120