

Acct ID: 519823 MTL: 063W24C001200 Date: 6/3/25 Appr: GRH Prop Class: 551 RMV Prop Class: 551
 Situs: 2415 PERKINS ST NE SALEM OR 97303 MaSaNh: 04 06 000 Unit: 49823 Year: 2024

Last Date Appraised: 09/04/2008 Appraiser: GERARDO RAMIREZ HERNANDEZ Retag: Y N Tag info: 2024 - Tags/Permit (Addition)

Owner: THACKERY, WAYNE A Roll Type: R

Cycle Tag Sales Verification Other: _____ Inspection level: 1 2 3 4 LCB TTO INSP
 RMV Land: 268550 RMV Imp: 477190 RMV Total: 745740 MAV: 381170 MSAV: 31184

AV: 362354 SAV: 60391

Comment: Changes on tags work flow 2025

No changes

Notations

RP/MS	Code	Description
RP	ZONED	FARM EFU ZONED

OSDs

Count	Code	Description	RMV	Code Area	Exception
1	SAA	SA OSD - AVERAGE	45000	01410	0

Land

Site: 2 Code Area: 01410 Size: 1.00 Acres Use Code: 005 Zone: REST SAV Use: 011 Exception: 0
 Class: Value Source: Farm Homesite Description: RMV: 38790 Exception: Y N
 Adjustment(s): GSOIL Fire Patrol: Description:
 Comments: Liability year - 2009 / 100210

Site: 3 Code Area: 01410 Size: 4.33 Acres Use Code: 005 Zone: REST SAV Use: 011 Exception: 0
 Class: 2BD Value Source: Farm Use - EFU Description: TWO BENCH DRY RMV: 184760 Exception: Y N
 Adjustment(s): GSOIL Fire Patrol: Description:
 Comments: Liability year - 1988 / 100210

Improvements - Residence / Manufactured Structures

Bldg: 1 Code Area: 01410 Stat Class: 152 - Year Blt: 1989 Eff Year Blt: 1989 Sq.Ft: 1983 % Complete: 100
 Desc: Multi Story above grade Dimensions: RMV: 377470
 Func Obsc: 100 Econ %: 100 Other %: 100 Exception: 0 Adjust: Adjust RMV: 0

Floors

Type	Class	Display Group	Floor Size	Beds	Baths	Yr Blt	Eff Yr Blt	Inventory	Exception
First Floor	5 -	Finished	1295	1	FB-1	1989	1989	BATH - 1, KIT, HVAC+, ROOF+	Y N
Second Floor	5 -	Finished	688	3	FB-2	1989	1989	BATH - 2, HVAC+	Y N
Garage Attached	5	Finished	649	0	0	1989	1989	ROOF+	Y N

Accessories

Description	Class	Size SqFt	Eff Yr Blt	RMV	Quantity	Exception
YARD IMPROVEMENTS FAIR	5	1	1989	23531	1	Y N

Bldg: 4 Code Area: 01410 Stat Class: 108 Year Blt: 1989 Eff Year Blt: 1989 Sq.Ft: 0 % Complete: 100
 Desc: Residential Other Improvements Dimensions: RMV: 3740
 Func Obsc: 100 Econ %: 100 Other %: 100 Exception: 0 Adjust: Adjust RMV: 0

Floors

Type	Class	Display Group	Floor Size	Beds	Baths	Yr Blt	Eff Yr Blt	Inventory
No floor data available								

Accessories

Description	Class	Size SqFt	Eff Yr Blt	RMV	Quantity	Exception
ASPHALT DRIVEWAY	1	1500	1989	3735	1	Y N

Improvements - Accessory Buildings

Bldg: 2 Code Area: 01410 Stat Class: 351 Year Blt: 1980 Eff Year Blt: 2002 Sq.Ft: 720 % Complete: 100
 Desc: General Purpose Building (GB) Dimensions: 30x24 RMV: 9610
 Func Obsc: 100 Econ %: 100 Other %: 100 Exception: 0 Adjust: Adjust RMV: 0

Floors

Type	Class	Display Group	Floor Size	Beds	Baths	Yr Blt	Eff Yr Blt	Inventory	Exception
General Purpose Bldg	5	Finished	720	0	0	1980	2002	FAIR	Y N

Accessories

Description	Class	Size SqFt	Eff Yr Blt	RMV	Quantity
-------------	-------	-----------	------------	-----	----------

No accessory data available

Bldg: 3 Code Area: 01410 Stat Class: 341 Year Blt: 1980 Eff Year Blt: 2002 Sq.Ft: 224 % Complete: 100
 Desc: Multi Purpose Shed (MP) Dimensions: 16x14 RMV: 3400
 Func Obsc: 100 Econ %: 100 Other %: 100 Exception: 0 Adjust: Adjust RMV: 0

Floors

Type	Class	Display Group	Floor Size	Beds	Baths	Yr Blt	Eff Yr Blt	Inventory	Exception: Y N
Multi-Purpose Bldg	5	Finished	224	0	0	1980	2002	FAIR	

Accessories

Description	Class	Size SqFt	Eff Yr Blt	RMV	Quantity
-------------	-------	-----------	------------	-----	----------

No accessory data available

Bldg: 5 Code Area: 01410 Stat Class: 342 Year Blt: 2001 Eff Year Blt: 2001 Sq.Ft: 4200 % Complete: 100
 Desc: Metal Component Building (MC) Dimensions: 100x42 RMV: 82970
 Func Obsc: 100 Econ %: 100 Other %: 100 Exception: 0 Adjust: Adjust RMV: 0

Floors

Type	Class	Display Group	Floor Size	Beds	Baths	Yr Blt	Eff Yr Blt	Inventory	Exception: Y N
Metal Componet Bldg	5	Finished	4200	0	0	2001	2001	AVG	

Accessories

Description	Class	Size SqFt	Eff Yr Blt	RMV	Quantity
-------------	-------	-----------	------------	-----	----------

No accessory data available

SKETCH/AREA TABLE ADDENDUM

SUBJECT INFO

File No.: 519823 Parcel No.: 063W24C 01200
 Property Address: 2415 PERKINS ST NE
 City: SALEM County: MARION State: OR ZipCode: 97303
 Owner:
 Client: Client Address:
 Appraiser Name: Inspection Date: 9/12/07

SKETCH

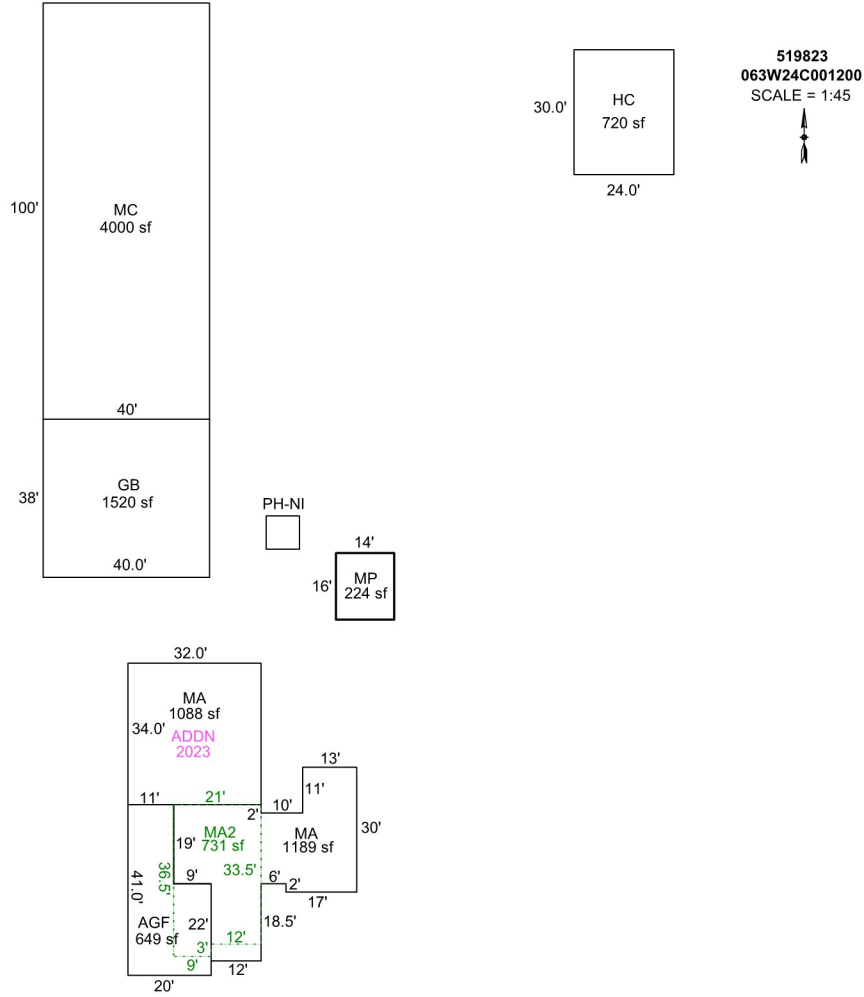

Sketch by Apex Sketch

AREA CALCULATIONS SUMMARY

Code	Description	Factor	Net Size	Perimeter	Net Totals
GBA1	MP	1.0	224.0	60.0	
	HC	1.0	720.0	108.0	944.0
GLA1	MA	1.0	1189.0	189.0	
	MC	1.0	4000.0	280.0	
	GB	1.0	1520.0	156.0	
GLA2	MA	1.0	1088.0	132.0	7797.0
	MA2	1.0	730.5	115.0	730.5
GAR	AGF	1.0	649.0	122.0	649.0
	Net LIVABLE	cnt	5 (rounded)		8,528
	Net BUILDING	cnt	2 (rounded)		944

COMMENT TABLE 1

UPDATED BY CJURAN 08/28/2023 555-23-005051
 UPDATED BY CJURAN 01/22/2024

COMMENT TABLE 2

MLH 01/04/2024

COMMENT TABLE 3

TAGS L2