

# SKETCH/AREA TABLE ADDENDUM

## SUBJECT INFO

File No.: 606427 Parcel No.: 093W14D002100  
 Property Address: 12121 HAPPY WAY SE  
 City: JEFFERSON County: Marion State: OR ZipCode:  
 Owner:  
 Client: Client Address:  
 Appraiser Name: Inspection Date:

## SKETCH

606427  
093W14D002100  
SCALE 1:30

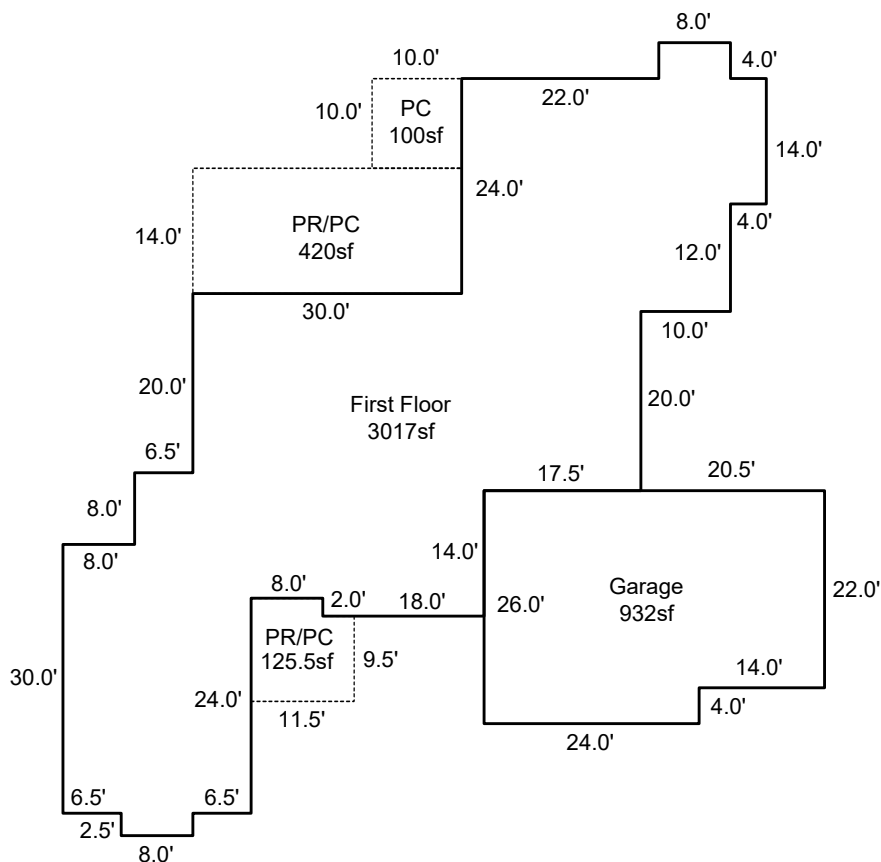

Sketch by ApexSketch

### AREA CALCULATIONS SUMMARY

Code	Description	Factor	Net Size	Perimeter	Net Totals
GAR	Garage	1.0	932.0	128.0	932.0
MA	First Floor	1.0	3017.0	338.0	3017.0
P/P	PR/PC	1.0	125.3	46.0	
	PR/PC	1.0	420.0	88.0	
	PC	1.0	100.0	40.0	645.3

### COMMENT TABLE 1

APEX BY CLOBERG 07/02/25

### COMMENT TABLE 2

### COMMENT TABLE 3

Net LIVABLE                      cnt                      1      (rounded)                      3,017