

Acct ID: 536331 MTL: 093W14C000900 Date: 5/15/25 Appr: MLH Prop Class: 401 RMV Prop Class: 401
 Situs: 11832 JEFFERSON HWY 99E SE JEFFERSON OR 97352 MaSaNh: 07 06 006 Unit: 25786 Year: 2025

Last Date Appraised: 02/24/2015 Appraiser: MATT LORD Retag: Y N Tag info:
 Owner: GILMORE, LORELEI G & GILMORE, RICHARD W Roll Type: R
 Cycle Tag Sales Verification Other: Clean up Inspection level: 1 2 3 4 LCB TTO INSP AV: 374440
 RMV Land: 398170 RMV Imp: 551080 RMV Total: 949250 MAV: 374440 MSAV: 0 SAV: 0
 Comment:

Notations

update Inventory

Input MLH 5/22/25

No notation data available.

OSDs

Count	Code	Description	RMV	Code Area	Exception
1	MKTG	OSD - GOOD	60000	14530	0

Land

Site: 1 Code Area: 14530 Size: 9.91 Acres Use Code: 004 Zone: NREST SAV Use: Exception: 0
 Class: 4B055 Value Source: Rural at MKT Description: RMV: 338170 Exception: Y N
 Adjustment(s): Fire Patrol: Description:
 Comments: 2003-04 REAPPRAISAL. 04-05: RECALC PROJECT, LAND SCHEDULE CHANGES.

Improvements - Residence / Manufactured Structures

Bldg: 1 Code Area: 14530 Stat Class: 144 + Year Blt: 1910 Eff Year Blt: 1961 Sq.Ft: 2934 % Complete: 100
 Desc: Multi Story above grade with basement Dimensions: RMV: 436270
 Func Obsc: 100 Econ %: 100 Other %: 100 Exception: 0 Adjust: Adjust RMV: 0 *n/c*

Floors

Type	Class	Display Group	Floor Size	Beds	Baths	Yr Blt	Eff Yr Blt	Inventory	Exception
First Floor	4 +	Finished	1467	0	FB-1	1910	1961	KIT+, ROOF, FP - 2, HVAC, BATH - 1	Y N
Second Floor	4 +	Finished	1467	5	FB-1	1910	1961	HVAC, BATH - 1	Y N
Basement	4 -	Unfinished	1467	0	0	1910	1961		Y N

Accessories

Description	Class	Size SqFt	Eff Yr Blt	RMV	Quantity	Exception
YARD IMPROVEMENTS GOOD	4	1	1961	29960	1	Y N

Bldg: 2 Code Area: 14530 Stat Class: 148 Year Blt: 1960 Eff Year Blt: 1960 Sq.Ft: 0 % Complete: 100
 Desc: Res other improvements Dimensions: RMV: 78680
 Func Obsc: 100 Econ %: 100 Other %: 100 Exception: 0 Adjust: Adjust RMV: 0 *I/O*

Floors

Type	Class	Display Group	Floor Size	Beds	Baths	Yr Blt	Eff Yr Blt	Inventory	Exception
Garage Oversized Detached	4	Finished	1440	0	0	1960	1960	ROOF	Y N

Accessories

Description	Class	Size SqFt	Eff Yr Blt	RMV	Quantity
No accessory data available					

Improvements - Accessory Buildings

Bldg: 3 Code Area: 14530 Stat Class: 301 Year Blt: Eff Year Blt: Sq.Ft: 0 % Complete: 100
 Desc: Accessory Improvements & Misc. Dimensions: RMV: 2000
 Func Obsc: 100 Econ %: 100 Other %: 100 Exception: 0 Adjust: Adjust RMV: 0

Floors

Gate part of YI move MAU

Type	Class	Display Group	Floor Size	Beds	Baths	Yr Blt	Eff Yr Blt	Inventory	Exception
Building Structure	0	Finished	0	0	0	0	0		Y N

Accessories

Description	Class	Size SqFt	Eff Yr Blt	RMV	Quantity
No accessory data available					

Bldg: 4 Code Area: 14530 Stat Class: 351 Year Blt: 2013 Eff Year Blt: 2013 Sq.Ft: 1728 % Complete: 100
 Desc: General Purpose Building (GB) Dimensions: 48x36 RMV: 34130
 Func Obsc: 100 Econ %: 100 Other %: 100 Exception: 0 Adjust: Adjust RMV: 0 *I/O*

Floors

Type	Class	Display Group	Floor Size	Beds	Baths	Yr Blt	Eff Yr Blt	Inventory	Exception: Y N
General Purpose Bldg	6	Finished	1728	0	0	2013	2013	FAIR <i>Ave</i>	

Accessories

Description	Class	Size SqFt	Eff Yr Blt	RMV	Quantity
No accessory data available					

341 MP 6 12x18 2019 Fair NEW
 354 LTL 6x18 2019 NEW

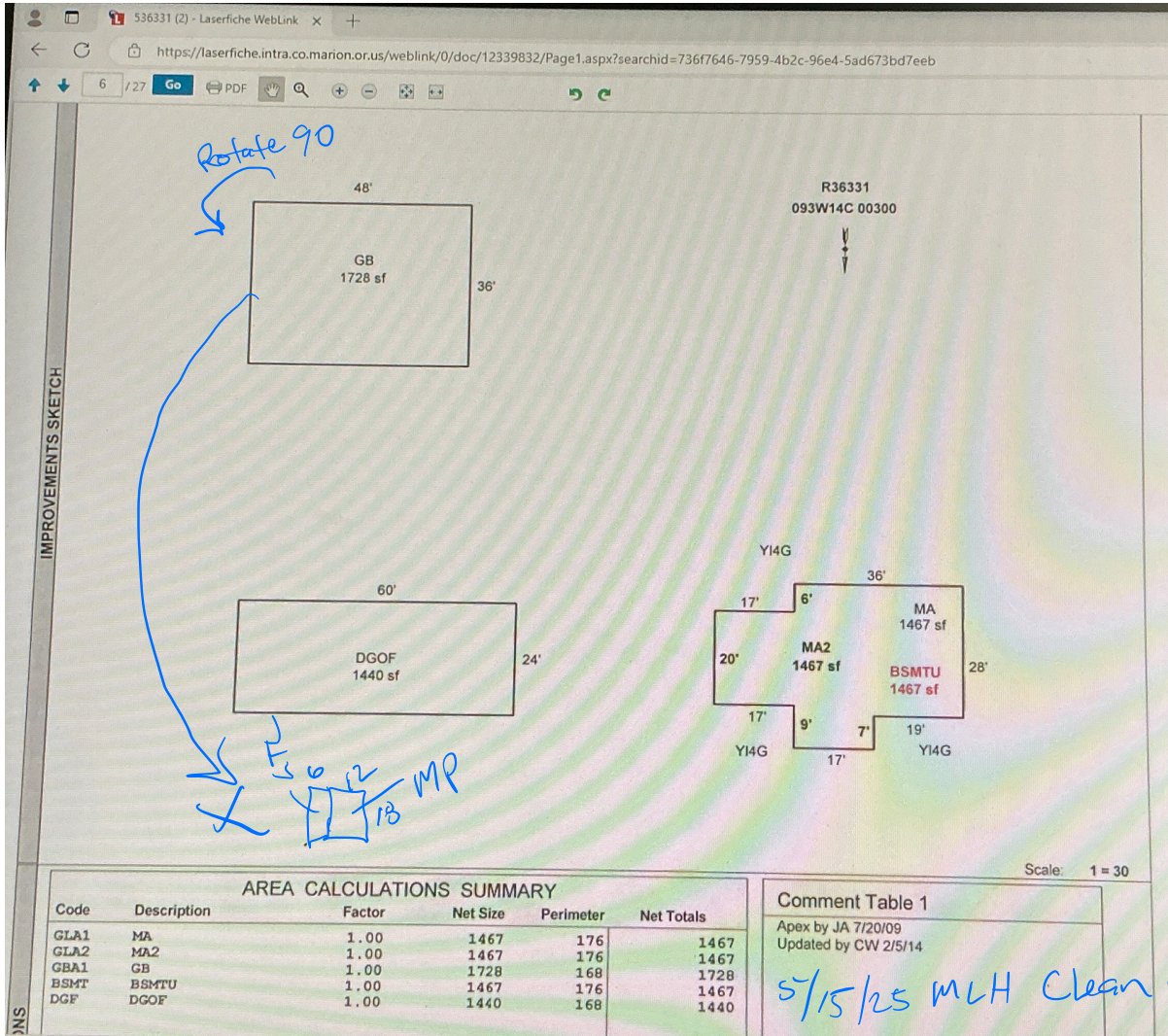

SKETCH/AREA TABLE ADDENDUM

SUBJECT INFO

File No.: 536331 Parcel No.: 093W14C 00300
 Property Address: 11832 Jefferson HY 99E SE
 City: Jefferson County: State: OR ZipCode: 97352
 Owner:
 Client: Client Address:
 Appraiser Name: Inspection Date:

SKETCH

536331
093W14C 00300

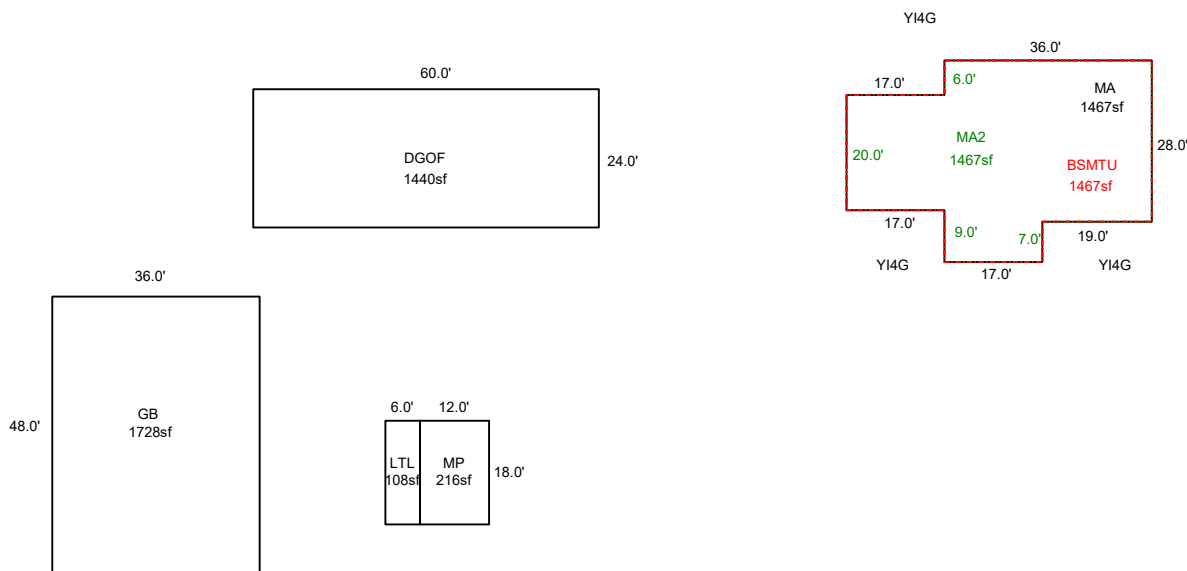

Sketch by ApexSketch

AREA CALCULATIONS SUMMARY						COMMENT TABLE 1			
Code	Description	Factor	Net Size	Perimeter	Net Totals				
GBA1	GB	1.0	1728.0	168.0		Apex by JA 7/20/09 Updated by CW 2/5/14 UPDATED BY CLOBERG 05/22/25			
	MP	1.0	216.0	60.0					
	LTL	1.0	108.0	48.0	2052.0				
GLA1	MA	1.0	1467.0	176.0	1467.0				
GLA2	MA2	1.0	1467.0	176.0	1467.0				
BSMT	BSMTU	1.0	1467.0	176.0	1467.0				
DGF	DGOF	1.0	1440.0	168.0	1440.0				
								COMMENT TABLE 2	COMMENT TABLE 3
								MLH 05/15/25	CLEAN UP L4
		Net LIVABLE	cnt	0 (rounded)	2,934				
		Net BUILDING	cnt	3 (rounded)	2,052				





R36331GB (2)

02-25-2015



R36331GB

03-2-2014

