

Summary

WW 5.12.25

Lead Appr: Clerk: Lead Clerk: Appr: MLH 5/14/25

Print Date: 4/16/2025

Acct ID: 535141 MTL: 092W070001400 Date: 4/25/25 Appr: MLH Prop Class: 551 RMV Prop Class: 551 501
Situs: 4348 ROUSE LN SE TURNER OR 97392 MaSaNh: 07 06 000 Unit: 59269 Year: 2025
Last Date Appraised: 12/07/2011 Appraiser: MATT LORD Retag: Y N Tag info:
Owner: IRMA ROUSE TR & ROUSE, IRMA TRE & Roll Type: R
Cycle Tag Sales Verification Other: Clean up Inspection level: 1 2 3 4 LCB TTO INSP AV: 359952
RMV Land: 460190 RMV Imp: 612030 RMV Total: 1072220 MAV: 325030 MSAV: 34922 SAV: 55995
Comment:

Update Inventory

Input MLH 5/9/25

Notations

Table with 3 columns: RP/MS, Code, Description. Row 1: RP, ZONED, FARM EFU ZONED

OSDs

Table with 6 columns: Count, Code, Description, RMV, Code Area, Exception. Row 1: 1, SAA, SA OSD - AVERAGE, 50000, 05590, 0

Land

Site: 1 Code Area: 05590 Size: 1.00 Acres Use Code: 005 Zone: REST SAV Use: 011 Exception: 0
Class: Value Source: Farm Homesite Description: RMV: 14240 Exception: Y N
Adjustment(s): Fire Patrol: Description:

Comments: Liability year - 2009 / 500190/00-01; SEPERATED INCREMENT FROM HOMESITE. /02-03: reappraisal

Site: 2 Code Area: 05590 Size: 24.06 Acres Use Code: 005 Zone: REST SAV Use: 011 Exception: 0
Class: 4HD Value Source: Farm Use - EFU Description: FOUR HILL DRY RMV: 342560 Exception: Y N
Adjustment(s): Fire Patrol: Description:

Comments: Liability year - 1981 / 500190: 01-02; CHANGED SOIL CLASS FROM 3 HILL DRY TO 4 HILL DRY /02-03: reappraisal

Site: 3 Code Area: 05590 Size: 3.75 Acres Use Code: 005 Zone: REST SAV Use: 011 Exception: 0
Class: WOOD Value Source: Woodlot Description: FARM WOODLOT RMV: 53390 Exception: Y N
Adjustment(s): Fire Patrol: Description:

Comments: Liability year - 1981 / 00500190 /02-03: reappraisal

EJB Roof Paint 1979

Improvements - Residence / Manufactured Structures

Bldg: 1 Code Area: 05590 Stat Class: 152 Year Blt: 1966 Eff Year Blt: 1966 Sq.Ft: 3574 % Complete: 100
Desc: Multi Story above grade Dimensions: RMV: 543170
Func Obsc: 100 Econ %: 100 Other %: 100 Exception: 0 Adjust: Adjust RMV: 0

I/O

Floors

Table with 10 columns: Type, Class, Display Group, Floor Size, Beds, Baths, Yr Blt, Eff Yr Blt, Inventory, Exception. Rows for First Floor, Attic, Garage Attached.

Accessories

Table with 7 columns: Description, Class, Size SqFt, Eff Yr Blt, RMV, Quantity, Exception. Row: YARD IMPROVEMENTS AVERAGE

Improvements - Accessory Buildings

Bldg: 2 Code Area: 05590 Stat Class: 353 Year Blt: 1995 Eff Year Blt: 1995 Sq.Ft: 522 % Complete: 100
Desc: Machine Shed (MS) Dimensions: 29x18 RMV: 2490
Func Obsc: 100 Econ %: 100 Other %: 100 Exception: 0 Adjust: 42x26 Adjust RMV: 0

I/O

Floors

Table with 10 columns: Type, Class, Display Group, Floor Size, Beds, Baths, Yr Blt, Eff Yr Blt, Inventory, Exception. Row: Machine Shed

Accessories

No accessory data available

Bldg: 3 Code Area: 05590 Stat Class: 351 Year Blt: 1995 Eff Year Blt: 1995 Sq.Ft: 1080 % Complete: 100
Desc: General Purpose Building (GB) Dimensions: 60x18 RMV: 5710
Func Obsc: 100 Econ %: 100 Other %: 100 Exception: 0 Adjust: 70 Adjust RMV: 0

I/O

Floors

Type	Class	Display Group	Floor Size	Beds	Baths	Yr Blt	Eff Yr Blt	Inventory
General Purpose Bldg	4	Finished	1080	0	0	1995	1995	Fair Exception: Y N

**Accessories**

Description	Class	Size SqFt	Eff Yr Blt	RMV	Quantity
No accessory data available					

Bldg: 4 Code Area: 05590 Stat Class: 301 Year Blt: 1966 Eff Year Blt: 1966 Sq.Ft: 1158 % Complete: 100  
 Desc: Accessory Improvements & Misc. Dimensions: RMV: 55340  
 Func Obsc: 100 Econ %: 100 Other %: 100 Exception: 0 Adjust: Adjust RMV: 0

**Floors**

EP

Move MAV

Type	Class	Display Group	Floor Size	Beds	Baths	Yr Blt	Eff Yr Blt	Inventory
Building Structure	5	Finished	1158	0	0	1966	1966	Exception: Y N

**Accessories**

Description	Class	Size SqFt	Eff Yr Blt	RMV	Quantity
No accessory data available					

Bldg: 5 Code Area: 05590 Stat Class: 354 Year Blt: 1995 Eff Year Blt: 1995 Sq.Ft: 900 % Complete: 100  
 Desc: Lean-to Light (LTL) Dimensions: 15x60<sup>70</sup> RMV: 1530  
 Func Obsc: 100 Econ %: 100 Other %: 100 Exception: 0 Adjust: Adjust RMV: 0 I/O

**Floors**

Type	Class	Display Group	Floor Size	Beds	Baths	Yr Blt	Eff Yr Blt	Inventory
Lean-to Light Duty	4	Finished	900	0	0	1995	1995	Exception: Y N

**Accessories**

Description	Class	Size SqFt	Eff Yr Blt	RMV	Quantity
No accessory data available					

Bldg: 6 Code Area: 05590 Stat Class: 354 Year Blt: 1995 Eff Year Blt: 1995 Sq.Ft: 900 % Complete: 100  
 Desc: Lean-to Light (LTL) Dimensions: 15x60<sup>70</sup> RMV: 1530  
 Func Obsc: 100 Econ %: 100 Other %: 100 Exception: 0 Adjust: Adjust RMV: 0 I/O

**Floors**

Type	Class	Display Group	Floor Size	Beds	Baths	Yr Blt	Eff Yr Blt	Inventory
Lean-to Light Duty	4	Finished	900	0	0	1995	1995	Exception: Y N

**Accessories**

Description	Class	Size SqFt	Eff Yr Blt	RMV	Quantity
No accessory data available					

Bldg: 7 Code Area: 05590 Stat Class: 341 Year Blt: 1995 Eff Year Blt: 1995 Sq.Ft: 320 % Complete: 100  
 Desc: Multi Purpose Shed (MP) <sup>GB</sup> Dimensions: 26x26 RMV: 2260  
 Func Obsc: 100 Econ %: 100 Other %: 100 Exception: 0 Adjust: Adjust RMV: 0

**Floors**

Type	Class	Display Group	Floor Size	Beds	Baths	Yr Blt	Eff Yr Blt	Inventory
Multi-Purpose Bldg	5	Finished	320	0	0	1995	1995	AJE Exception: Y N

**Accessories**

Description	Class	Size SqFt	Eff Yr Blt	RMV	Quantity
No accessory data available					

# SKETCH/AREA TABLE ADDENDUM

## SUBJECT INFO

File No.: 535141 Parcel No.: 092W 07 01400  
 Property Address: 4348 Rouse Lane SE  
 City: Turner County: State: OR ZipCode: 97392  
 Owner:  
 Client: Client Address:  
 Appraiser Name: Inspection Date:

## SKETCH

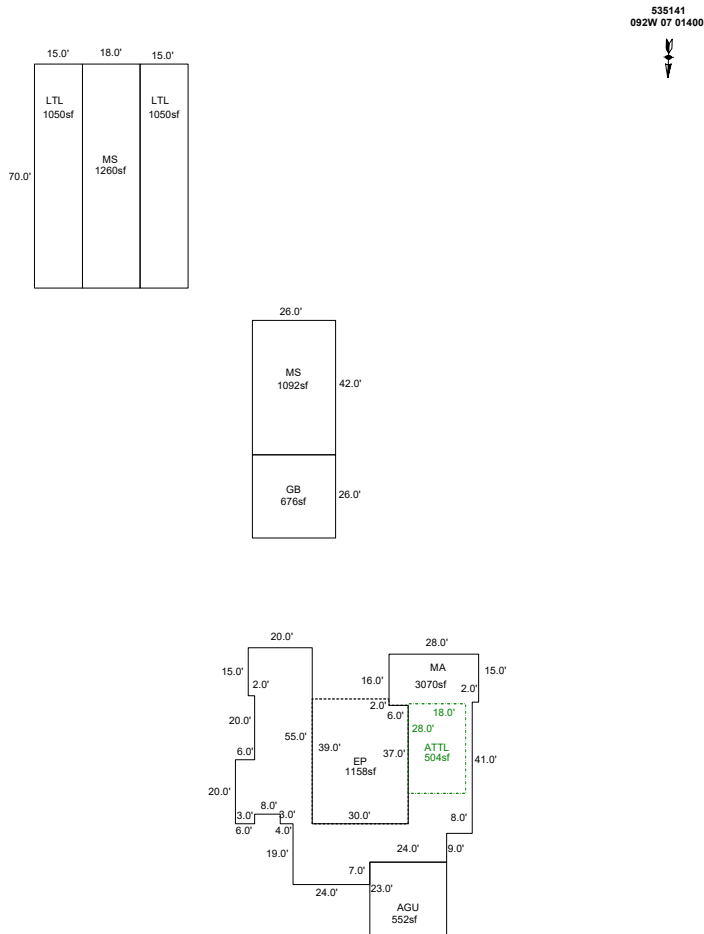

Sketch by ApexSketch

AREA CALCULATIONS SUMMARY						COMMENT TABLE 1	
Code	Description	Factor	Net Size	Perimeter	Net Totals		
GBA1	MS	1.0	1092.0	136.0		APEX BY JA 1/23/12 UPDATED BY CLOBERG 05/07/25	
	MS	1.0	1260.0	176.0			
	LTL	1.0	1050.0	170.0			
	LTL	1.0	1050.0	170.0			
	GB	1.0	676.0	104.0	5128.0		
GLA1	MA	1.0	3070.0	428.0	3070.0		
GLA2	ATTL	1.0	504.0	92.0	504.0		
GAR	AGU	1.0	552.0	94.0	552.0		
P/P	EP	1.0	1158.0	138.0	1158.0		
						COMMENT TABLE 2	COMMENT TABLE 3
						MLH 04/25/25	CLEAN UP L4
Net LIVABLE		cnt	0	(rounded)	3,574		
Net BUILDING		cnt	5	(rounded)	5,128		

R35141  
092W 07 01400

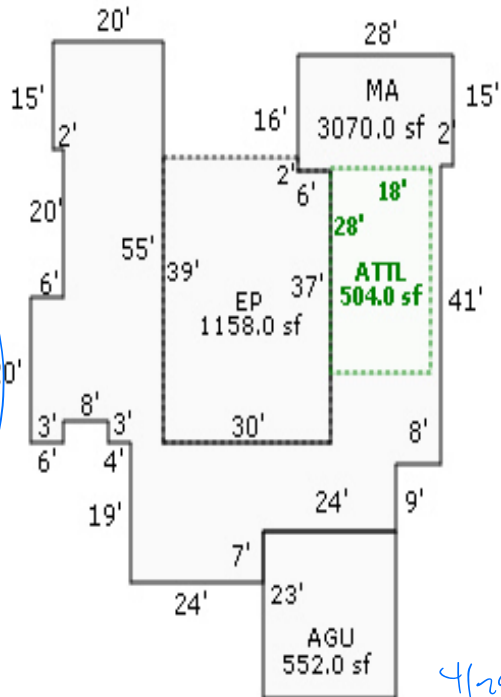
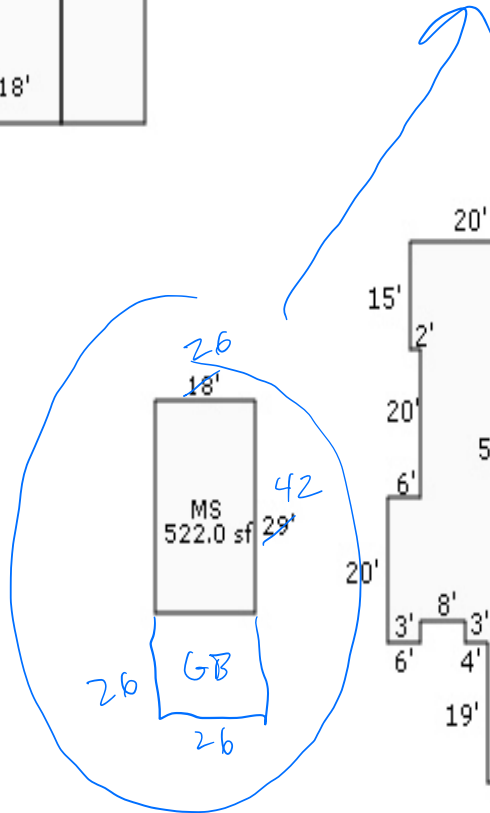
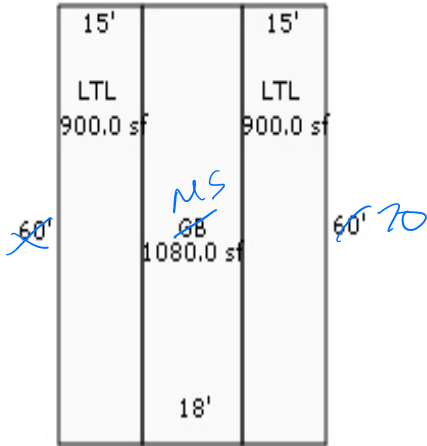
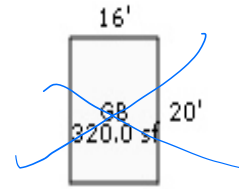

4/25/25 MLT Clean 4P  
LY