

Acct ID: 558202 MTL: 082W11B005400 Date: **5/2/25** Appr: **MLH** Prop Class: 401 RMV Prop Class: 401
 Situs: 3998 78TH AVE SE SALEM OR 97317 MaSaNh: 01 06 004 Unit: 113235 Year: 2025

Last Date Appraised: 09/19/2019 Appraiser: CLINT LUKE Retag: Y N Tag info:
 Owner: VAUGHN, MICHAEL & VAUGHN, JACLYN Roll Type: R
 Cycle Tag Sales Verification Other: **Clean up** Inspection level: 1 2 3 4 LCB TTO INSP AV: 455330
 RMV Land: 339070 RMV Imp: 452280 RMV Total: 791350 MAV: 455330 MSAV: 0 SAV: 0
 Comment:

Notations

No notation data available.

update inventory

Input MLH 5/2/25

OSDs

Count	Code	Description	RMV	Code Area	Exception
1	MKTG	OSD - GOOD	60000	92410	0

Land

Site: 1 Code Area: 92410 Size: 2.58 Acres Use Code: 004 Zone: NREST SAV Use: Exception: 0
 Class: **2BD** Value Source: Rural at MKT Description: RMV: 279070 Exception: Y N
 Adjustment(s): **GSOIL** Fire Patrol: Description:
 Comments: 02-03: REAPPRAISAL

Improvements - Residence / Manufactured Structures

Bldg: 1 Code Area: 92410 Stat Class: 142 + Year Blt: 1981 Eff Year Blt: 1981 Sq.Ft: 2810 % Complete: 100
 Desc: Multi Story above grade Dimensions: RMV: 439270
 Func Obsc: 100 Econ %: 100 Other %: 100 Exception: 0 Adjust: Adjust RMV: 0

Floors

Type	Class	Display Group	Floor Size	Beds	Baths	Yr Blt	Eff Yr Blt	Inventory	Exception
First Floor	4 +	Finished	1324	0	FB-1/ HB-1	1981	1981	HVAC, KIT, ROOF, FP - 1, BTH - 1	Exception: Y N
Second Floor	4 +	Finished	1044	3	FB-2	1981	1981	HVAC, BATH - 2	Exception: Y N
Attic	4 +	Finished	280	1	0	1981	1981	HVAC	Exception: Y N
Attic	4 +	Low Cost	162	0	0	1981	1981		Exception: Y N
Garage Attached	4	Finished	729	0	0	1981	1981	ROOF	Exception: Y N

Accessories

Description	Class	Size SqFt	Eff Yr Blt	RMV	Quantity	Exception
CONCRETE DRIVEWAY	4	280	1981	719	1	Exception: Y N
CONCRETE DRIVEWAY	4	486	1981	1247	1	Exception: Y N
DECK	4	108	1981	1877	1	Exception: Y N
PATIO	4	120	1981	521	1	Exception: Y N
PATIO	4	288	1981	1251	1	Exception: Y N
PATIO	4	1100	1981	4780	1	Exception: Y N
ROOF EXTENSION OR PATIO COVER	4	120	1981	2749	1	Exception: Y N

Bldg: 2 Code Area: 92410 Stat Class: 108 Year Blt: 1981 Eff Year Blt: 1981 Sq.Ft: 0 % Complete: 100
 Desc: Residential Other Improvements Dimensions: RMV: 4480
 Func Obsc: 100 Econ %: 100 Other %: 100 Exception: 0 Adjust: Adjust RMV: 0

Floors

Type	Class	Display Group	Floor Size	Beds	Baths	Yr Blt	Eff Yr Blt	Inventory	Exception
No floor data available									

Accessories

Description	Class	Size SqFt	Eff Yr Blt	RMV	Quantity	Exception
ASPHALT DRIVEWAY	1	1890	1981	4479	1	Exception: Y N

Improvements - Accessory Buildings

Bldg: 3 Code Area: 92410 Stat Class: 301 Year Blt: 1981 Eff Year Blt: 1981 Sq.Ft: 146 % Complete: 100
 Desc: Accessory Improvements & Misc. Dimensions: RMV: 4680
 Func Obsc: 100 Econ %: 100 Other %: 100 Exception: 0 Adjust: Adjust RMV: 0

Floors

GA part of YI move MAU

Type	Class	Display Group	Floor Size	Beds	Baths	Yr Blt	Eff Yr Blt	Inventory
Building Structure	0	Finished	146	0	0	1981	1981	Exception: Y N

Accessories

Description	Class	Size SqFt	Eff Yr Blt	RMV	Quantity
No accessory data available					

Bldg: 4 Code Area: 92410 Stat Class: 351 Year Blt: 1981 Eff Year Blt: 1981 Sq.Ft: 1104 % Complete: 100
 Desc: General Purpose Building (GB) Dimensions: 46x24 RMV: 3380
 Func Obsc: 100 Econ %: 100 Other %: 100 Exception: 0 Adjust: Adjust RMV: 0

Floors

Type	Class	Display Group	Floor Size	Beds	Baths	Yr Blt	Eff Yr Blt	Inventory
General Purpose Bldg	4	Finished	1104	0	0	1981	1981	FAIR Exception: Y N

Accessories

Description	Class	Size SqFt	Eff Yr Blt	RMV	Quantity
No accessory data available					

Bldg: 5 Code Area: 92410 Stat Class: 354 Year Blt: 1981 Eff Year Blt: 1981 Sq.Ft: 584 % Complete: 100
 Desc: Lean-to Light (LTL) Dimensions: RMV: 470
 Func Obsc: 100 Econ %: 100 Other %: 100 Exception: 0 Adjust: Adjust RMV: 0

Floors

Type	Class	Display Group	Floor Size	Beds	Baths	Yr Blt	Eff Yr Blt	Inventory
Lean-to Light Duty	4	Finished	584	0	0	1981	1981	Exception: Y N

Accessories

Description	Class	Size SqFt	Eff Yr Blt	RMV	Quantity
No accessory data available					

R58202
 082W11B 05400
 SCALE=1:20

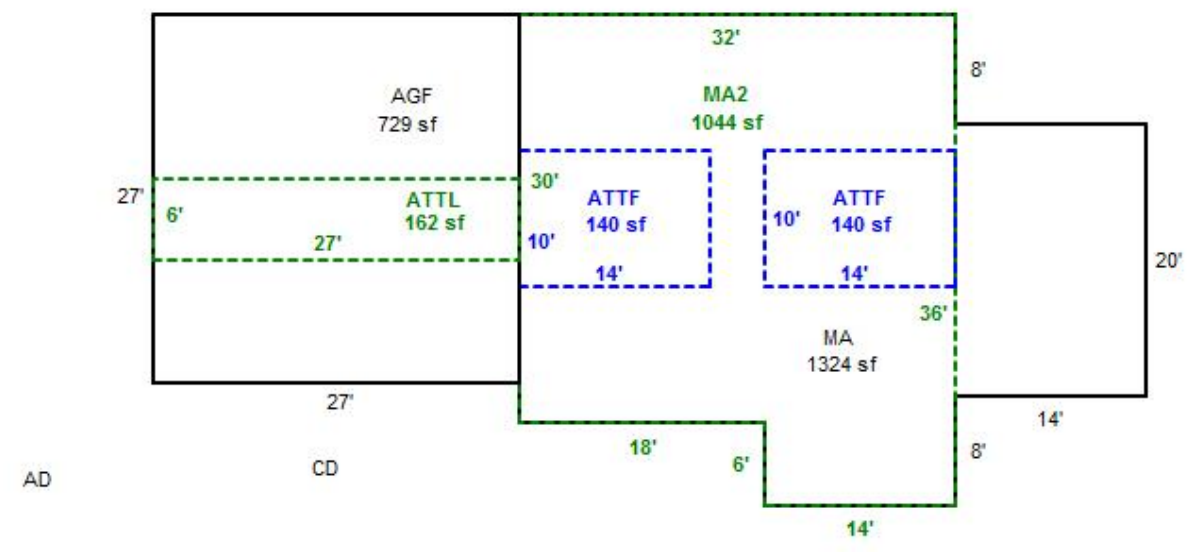
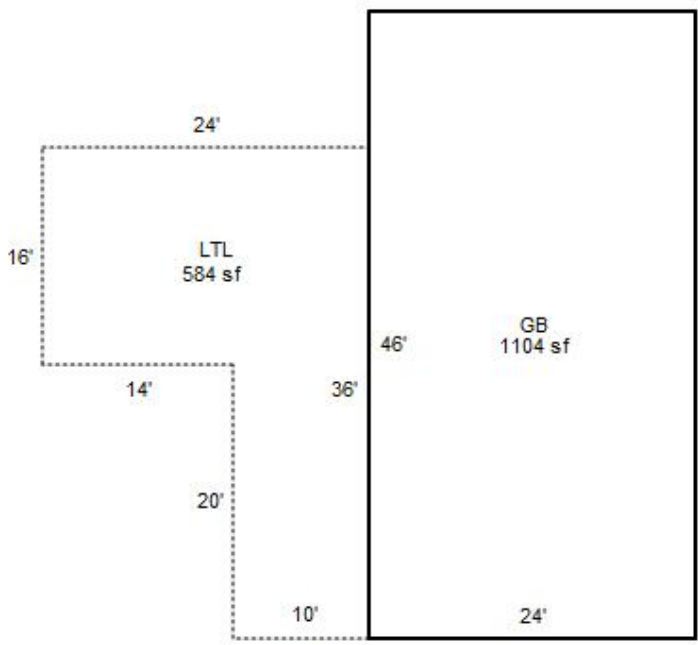
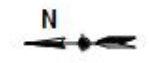

AD

CD



R58202

GB & LTL

7/20/17



R58202

MA, MA2, ATTF, AGF

7/20/17



R58202 MA, MA2, AGF E.SIDE
2019-09-19



R58202 PRG (Gazebo)
2019-09-19



R58202 GB 46X24 S.SIDE
2019-09-19



R58202 PQ (Paver Patio)
2019-09-19



R58202 GB 46X24 & LTL 584 SF
2019-09-19



R58202 MA, MA2, ATTF, AGF W.SIDE
2019-09-19