

Acct ID: 536234 MTL: 093W090000100 Date: 11/6/25 Appr: GRH Prop Class: 581 RMV Prop Class: 581
 Situs: 10095 LIBERTY RD S SALEM OR 97306 MaSaNh: 06 06 000 Unit: 76883 Year: 2024
 Last Date Appraised: 10/24/2023 Appraiser: WENDY WILLIAMS Retag: Y N Tag info: 2025 - Tags/Permit (Completion)
 Owner: HYNE, JOHN W Roll Type: R
 Cycle: 3 Tag: 1 Sales Verification Other: _____ Inspection level: 1 2 3 4 LCB TTO INSP AV: 269182
 RMV Land: 856860 RMV Imp: 480880 RMV Total: 1337740 MAV: 213030 MSAV: 56152 SAV: 99996
 Comment: 24-25 L3 MDL 10.24.23
 23-24: L2 12.14.22 MD
 22-23: L2 09.17.2021 MDL
 LEVEL 2 4.27.21 CL10

MA - no changes observed, AGEX not started.

Notations

RP/MS	Code	Description
RP	DFL	DESIGNATED FORESTLAND
RP	ZONED	FARM EFU ZONED

OSDs Chris 3/3/25 23-002699 AGEX - 12X24 LOAFING SHED FOR COWS. SFD NO CHANGE 23-002697

Count	Code	Description	RMV	Code Area	Exception
1	SAA	SA OSD - AVERAGE	45000	14530	0 <u>OFL:ok</u>

Land

Site	Code Area	Size	Use Code	Zone	SAV Use	Exception
Site: 2	Code Area: 14530	Size: 1.00 Acres	Use Code: 005	Zone: REST	SAV Use: 011	Exception: 0
Class: 4HD	Value Source: Farm Homesite	Description: FOUR HILL DRY			RMV: 48310	Exception: Y N
Adjustment(s):	VWGR, FSOIL	Fire Patrol:			Description:	
Comments:	Liability year - 2009 / 81400130					
Site: 3	Code Area: 14530	Size: 42.30 Acres	Use Code: 005	Zone: REST	SAV Use: 011	Exception: 0
Class: 4HD	Value Source: Farm Use - EFU	Description: FOUR HILL DRY			RMV: 563170	Exception: Y N
Adjustment(s):	VWGR, FSOIL	Fire Patrol:			Description:	
Comments:	Liability year - 1981 / 81400130 //08-09: 8BENCH PROJECT -CHG OF 8HILL TO 6HILL AND MOVE 6 ACRES TO 4HILL//					
Site: 4	Code Area: 14530	Size: 2.00 Acres	Use Code: 005	Zone: REST	SAV Use: 011	Exception: 0
Class: 6H	Value Source: Farm Use - EFU	Description: SIX HILL			RMV: 25300	Exception: Y N
Adjustment(s):	VWGR, FSOIL	Fire Patrol:			Description:	
Comments:	Liability year - 1981 / 81400130					
Site: 5	Code Area: 14530	Size: 10.00 Acres	Use Code: 005	Zone: REST	SAV Use: 011	Exception: 0
Class: 4HD	Value Source: Woodlot	Description: FOUR HILL DRY			RMV: 133140	Exception: Y N
Adjustment(s):	VWGR, FSOIL	Fire Patrol:			Description:	
Comments:	Liability year - 1981 / 81400130					
Site: 6	Code Area: 14530	Size: 3.15 Acres	Use Code: 005	Zone: REST	SAV Use: 011	Exception: 0
Class: FTLC	Value Source: Designated Forest Land	Description: DFL Class C			RMV: 41940	Exception: Y N
Adjustment(s):	VWGR, FSOIL	Fire Patrol:			Description:	
Comments:	Liability year - 1981 / 81400130					

Farm livestock ok

Improvements - Residence / Manufactured Structures

Bldg: 3 Code Area: 14530 Stat Class: 144 Year Blt: 2012 Eff Year Blt: 2012 Sq.Ft: 2678 % Complete: 73
 Desc: Multi Story above grade with basement Dimensions: RMV: 4608.0
 Func Obsc: 100 Econ %: 100 Other %: 100 Exception: 0 Adjust: Adjust RMV: 0

No changes to MIA observed.

Floors

Type	Class	Display Group	Floor Size	Beds	Baths	Yr Blt	Eff Yr Blt	Inventory	Exception
First Floor	4	Finished	1955	2	FB-1	2012	2012	BATH - 1, KIT-, HVAC, ROOF	Exception: Y N
Second Floor	4	Finished	723	1	FB-1	2012	2012	BATH - 1, ROOF	Exception: Y N
Basement	4	Unfinished	1283	0	FB-1/ HB-1	2012	2012	BTH - 1, HVAC	Exception: Y N
Garage Attached	4	Finished	550	0	0	2012	2012	ROOF	Exception: Y N
Garage Basement	4	Finished	672	0	0	2012	2012		Exception: Y N

Accessories

Description	Class	Size SqFt	Eff Yr Blt	RMV	Quantity
No accessory data available					

Improvements - Accessory Buildings

Bldg: 1 Code Area: 14530 Stat Class: 351 Year Blt: 1965 Eff Year Blt: 1965 Sq.Ft: 1920 % Complete: 100
 Desc: General Purpose Building (GB) Dimensions: 40x48 RMV: 5690

Func Obsc: 100

Econ %: 100

Other %: 100

Exception: 0

Adjust:

Adjust RMV: 0

Nlc

Floors

Type	Class	Display Group	Floor Size	Beds	Baths	Yr Blt	Eff Yr Blt	Inventory	Exception: Y N
General Purpose Bldg	4	Finished	1920	0	0	1965	1965	FAIR	

Accessories

Description	Class	Size SqFt	Eff Yr Blt	RMV	Quantity
No accessory data available					

Bldg: 2 Code Area: 14530 Stat Class: 353 Year Blt: 2011 Eff Year Blt: 2011 Sq.Ft: 1512 % Complete: 100
 Desc: Machine Shed (MS) Dimensions: 42x36 RMV: 10010
 Func Obsc: 100 Econ %: 100 Other %: 100 Exception: 0 Adjust: Adjust RMV: 0

I/O

Floors

Type	Class	Display Group	Floor Size	Beds	Baths	Yr Blt	Eff Yr Blt	Inventory	Exception: Y N
Machine Shed	4	Finished	1512	0	0	2011	2011	fair	

Accessories

Description	Class	Size SqFt	Eff Yr Blt	RMV	Quantity
No accessory data available					

Bldg: 4 Code Area: 14530 Stat Class: 355 Year Blt: 2012 Eff Year Blt: 2012 Sq.Ft: 480 % Complete: 100
 Desc: Lean-to Heavy (LTH) Dimensions: 30x16 RMV: 2530
 Func Obsc: 100 Econ %: 100 Other %: 100 Exception: 0 Adjust: Adjust RMV: 0

Nlc

Floors

Type	Class	Display Group	Floor Size	Beds	Baths	Yr Blt	Eff Yr Blt	Inventory	Exception: Y N
Lean-to Heavy Duty	4	Finished	480	0	0	2012	2012		

Accessories

Description	Class	Size SqFt	Eff Yr Blt	RMV	Quantity
No accessory data available					

Bldg: 5 Code Area: 14530 Stat Class: 353 Year Blt: 1965 Eff Year Blt: 1965 Sq.Ft: 912 % Complete: 100
 Desc: Machine Shed (MS) Dimensions: RMV: 1820
 Func Obsc: 100 Econ %: 100 Other %: 100 Exception: 0 Adjust: Adjust RMV: 0

I/O

Floors

Type	Class	Display Group	Floor Size	Beds	Baths	Yr Blt	Eff Yr Blt	Inventory	Exception: Y N
Machine Shed	4	Finished	912	0	0	1965	1965	fair	

Accessories

Description	Class	Size SqFt	Eff Yr Blt	RMV	Quantity
No accessory data available					

SKETCH/AREA TABLE ADDENDUM

SUBJECT INFO

File No.: 536234 Parcel No.: 093W09 00100
 Property Address: 10095 LIBERTY RD S
 City: SALEM County: State: OR ZipCode: 97306
 Owner:
 Client: Client Address:
 Appraiser Name: Inspection Date:

SKETCH

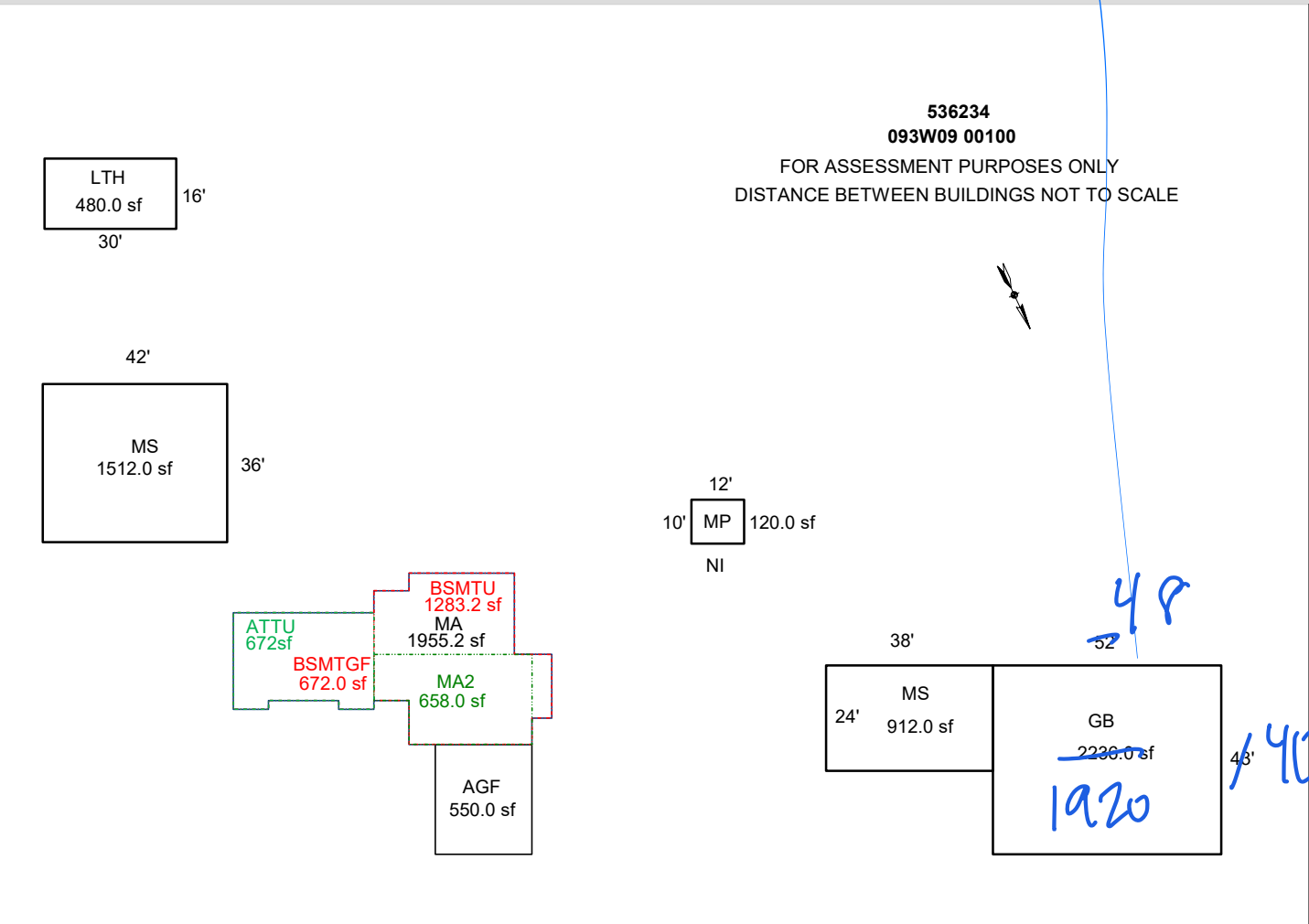

Sketch by ApexSketch

AREA CALCULATIONS SUMMARY

Code	Description	Factor	Net Size	Perimeter	Net Totals
GBA1	GB	1.0	2236.0	190.0	
	MS	1.0	912.0	124.0	
	MS	1.0	1512.0	156.0	
	LTH	1.0	480.0	92.0	
	MP	1.0	120.0	44.0	5260.0
GLA1	MA	1.0	1955.3	231.0	1955.3
GLA2	MA2	1.0	658.0	113.0	658.0
BSMT	BSMTU	1.0	1283.3	159.0	
	BSMTU	1.0	672.0	112.0	
	ATTU	1.0	672.0	112.0	2627.3
GARG	AGF	1.0	550.0	94.0	550.0
	Net LIVABLE	cnt	2 (rounded)		2,613
	Net BUILDING	cnt	5 (rounded)		5,260

COMMENT TABLE 1

APEX BY AC 5/17/13
 UPD BY JRONDEMA 5/20/15
 UPD BY JRONDEMA 1/16/18
 UPD BY PH 08.08.19
 UPDATED BY WWILLIAMS 2/29/24

COMMENT TABLE 2

11/19/18 #35
 MDL 10/24/23

GPA 11/16/25

COMMENT TABLE 3

TAGS L2

TAGS L2