

Acct ID: 330105 MTL: 082W11B006400 Date: 1-9-25 Appr: Cena Prop Class: 401 RMV Prop Class: 401
 Situs: 3892 75TH AVE SE SALEM OR 97317 MaSaNh: 01 06 004 Unit: 48348 INPUT 1-21-25 Cena Year: 2025
 Last Date Appraised: 08/25/2017 Appraiser: CLINT LUKE Retag: Y N Tag info: 2025 - Tags/Permit (Addition)
 Owner: HARI, RYAN W & HARI, HIDI L Roll Type: R
 Cycle Tag Sales Verification Other: _____ Inspection level: 1 2 3 4 LCB TTO INSP AV: 419860
 RMV Land: 290890 RMV Imp: 701090 RMV Total: 991980 MAV: 419860 MSAV: 0 SAV: 0
 Comment:

Notations
 No notation data available.

NEW GB

OSDs

Count	Code	Description	RMV	Code Area	Exception
1	MKTA	OSD - AVERAGE	50000	92410	0

Land

Site: 1 Code Area: 92410 Size: 1.58 Acres Use Code: 004 Zone: NREST SAV Use: Exception: 0
 Class: Value Source: Rural at MKT Description: RMV: 240890 Exception: Y N
 Adjustment(s): Fire Patrol: Description:
 Comments: 2002-03 REAPPRAISAL; 2003-04 MODIFIED LAND TABLE KKB65 10/02

Improvements - Residence / Manufactured Structures

Bldg: 1 Code Area: 92410 Stat Class: 152 Year Blt: 2002 Eff Year Blt: 2002 Sq.Ft: 3349 % Complete: 100
 Desc: Multi Story above grade Dimensions: RMV: 687120
 Func Obsc: 100 Econ %: 100 Other %: 100 Exception: 0 Adjust: Adjust RMV: 0

Floors

Type	Class	Display Group	Floor Size	Beds	Baths	Yr Blt	Eff Yr Blt	Inventory	Exception
First Floor	5	Finished	1754	1	FB-1/ HB-1	2002	2002	KIT-, HVAC+, FP, 1, BTH - 1, BATH - 1, ROOF	Exception: Y <u>N</u>
Second Floor	5	Finished	1343	3	FB-2	2002	2002	HVAC+, BATH - 2	Exception: Y N
Attic	5	Finished	252	0	0	2002	2002		Exception: Y N
Garage Attached	5	Finished	577	0	0	2002	2002	ROOF	Exception: Y N

Accessories

Description	Class	Size SqFt	Eff Yr Blt	RMV	Quantity	Exception
ASPHALT DRIVEWAY	5	4200	2010	11718	1	Exception: Y N
CONCRETE DRIVEWAY	5	2380	2002	6884	1	Exception: Y N
PATIO	5	947	2002	4635	1	Exception: Y N
ROOF EXTENSION OR PATIO COVER	5	627	2015	17456	1	Exception: Y N

Improvements - Accessory Buildings

Bldg: 2 Code Area: 92410 Stat Class: 351 Year Blt: 2004 Eff Year Blt: 2004 Sq.Ft: 1080 % Complete: 100
 Desc: General Purpose Building (GB) Dimensions: 30x36 RMV: 13970
 Func Obsc: 100 Econ %: 100 Other %: 100 Exception: 0 Adjust: Adjust RMV: 0

Floors

Type	Class	Display Group	Floor Size	Beds	Baths	Yr Blt	Eff Yr Blt	Inventory	Exception
General Purpose Bldg	5	Finished	1080	0	0	2004	2004	FAIR	Exception: Y <u>N</u>

Accessories

Description	Class	Size SqFt	Eff Yr Blt	RMV	Quantity
No accessory data available					

*GB 30X36 1080 R AVS 2025 NEW
 (TREATED AS A WHOLE BLDG NOT A ADDON)*

SKETCH/AREA TABLE ADDENDUM

SUBJECT INFO

File No.: 330105 Parcel No.: 082W11B 06400
 Property Address: 3892 75TH AVE SE
 City: Salem County: Marion State: OR ZipCode: 97317
 Owner:
 Client: Client Address:
 Appraiser Name: Inspection Date: ,

SKETCH

330105
082W11B 06400
SCALE=1:20

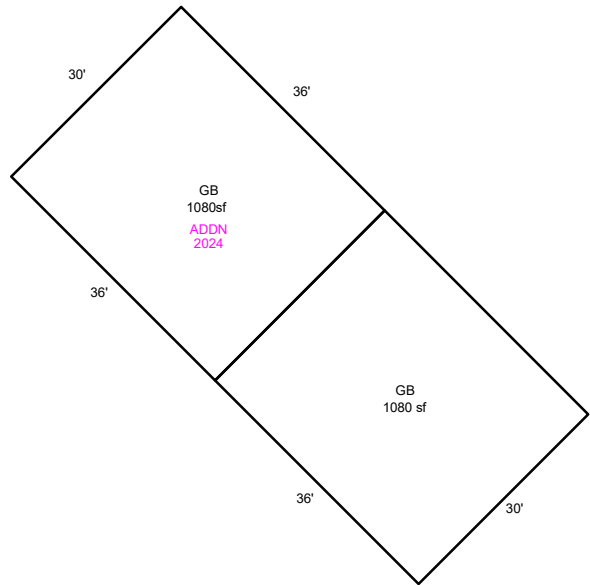
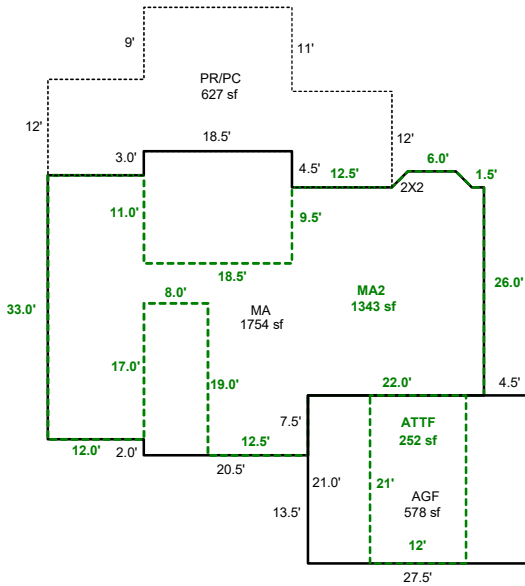

CD

Sketch by ApexSketch

AREA CALCULATIONS SUMMARY

Code	Description	Factor	Net Size	Perimeter	Net Totals
GBA1	GB	1.0	1080.0	132.0	
	GB	1.0	1080.0	132.0	2160.0
GLA1	MA	1.0	1754.0	186.7	1754.0
GLA2	MA2	1.0	1343.0	233.7	
	ATTF	1.0	252.0	66.0	1595.0
GAR	AGF	1.0	577.5	97.0	577.5
P/P	PR/PC	1.0	627.0	137.0	627.0

COMMENT TABLE 1

UPDATED BY JRONDEMA 12/2/15
 UPDATED BY JRONDEMA 9/19/17
 UPDATED BY CLOBERG 10/17/24 24-005998 GB ADDN

COMMENT TABLE 2

1.20.16 #94 TAGS
 8.25.17 SR #94 CYCLE, NV

COMMENT TABLE 3

Net LIVABLE	cnt	3	(rounded)		3,349
Net BUILDING	cnt	2	(rounded)		2,160



1/9/25