

SKETCH/AREA TABLE ADDENDUM

SUBJECT INFO

File No.: 606426 Parcel No.: 093W14D002000
 Property Address: 12091 HAPPY WAY SE
 City: JEFFERSON County: Marion State: OR ZipCode:
 Owner:
 Client: Client Address:
 Appraiser Name: Inspection Date:

SKETCH

606426
 093W14D002000
 SCALE 1:30

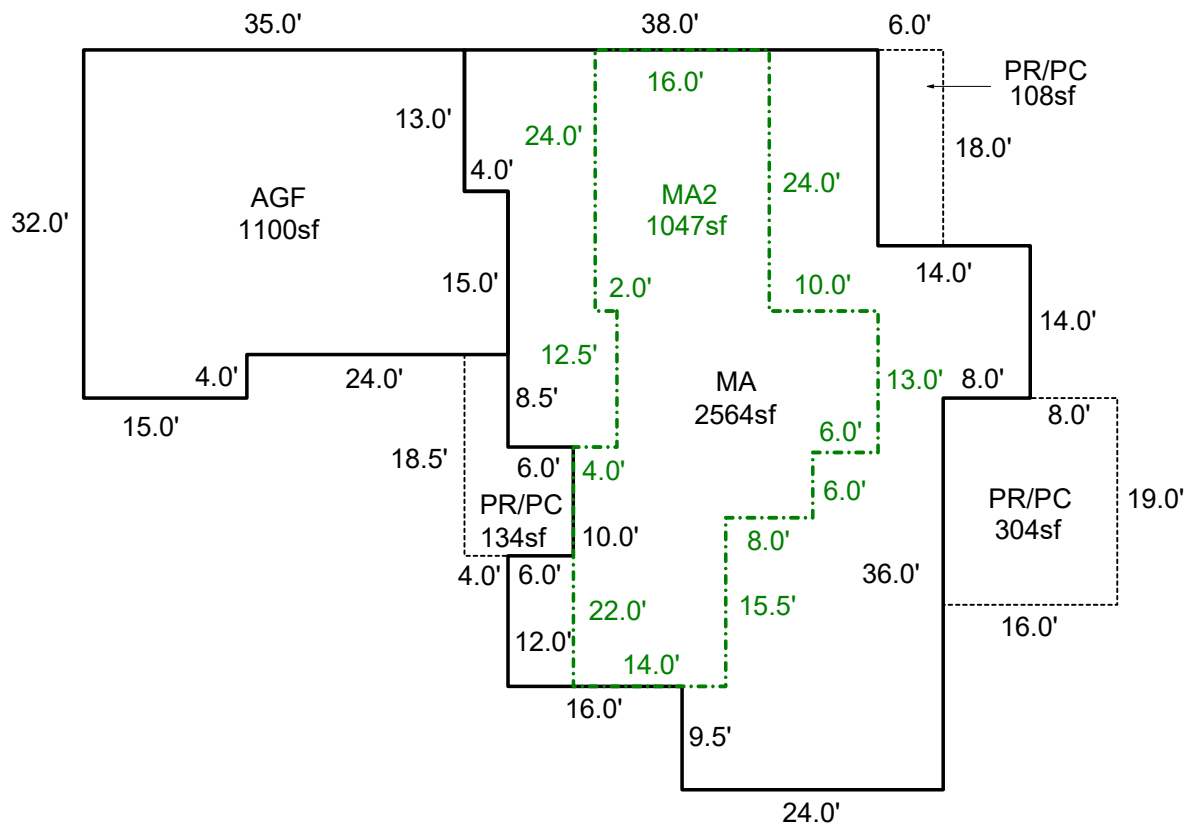

Sketch by ApexSketch

AREA CALCULATIONS SUMMARY						COMMENT TABLE 1	
Code	Description	Factor	Net Size	Perimeter	Net Totals	APEX BY CLOBERG 01/09/25 24-008215 MA	
MA2	MA2	1.0	1047.0	177.0	1047.0		
GAR	AGF	1.0	1100.0	142.0	1100.0		
MA	MA	1.0	2564.0	252.0	2564.0		
P/P	PR/PC	1.0	108.0	48.0			
	PR/PC	1.0	304.0	70.0			
	PR/PC	1.0	134.0	57.0	546.0		
	Net LIVABLE	cnt	2 (rounded)		3,611		
						COMMENT TABLE 2	COMMENT TABLE 3