

Acct ID: 560142 MTL: 071E34AA00800 Date: 12/17/24 Appr: MLH Prop Class: 451 RMV Prop Class: 451
 Situs: 590 LOAR RD SE SILVERTON OR 97381 MaSaNh: 03 06 000 Unit: 81543 Year: 2024
 Last Date Appraised: 03/11/2021 Appraiser: MATTHEW HAMILTON Retag: Y N Tag info: 2025 - Tags/Permit (Addition)
 Owner: COLLAZO, IAN VON Roll Type: R
 Cycle: Tag Sales Verification Other: _____ Inspection level: 1 2 3 4 LCB TTO INSP AV: 234420
 RMV Land: 315720 RMV Imp: 321530 RMV Total: 637250 MAV: 234420 MSAV: 0 SAV: 0
 Comment: LEVEL 2 03.11.21 CL10//

*MA addition @ 100 To update inventory
Close tag*

Notations No notation data available. Input MLH 12/30/24

OSDs

Count	Code	Description	RMV	Code Area	Exception
1	MKTF	OSD - FAIR	35000	04480	0

Land

Site: 1 Code Area: 04480 Size: 3.66 Acres Use Code: 005 Zone: REST SAV Use: Exception: 0
 Class: 4HD Value Source: Rural Restrictive Description: RMV: 280720 Exception: Y N
 Adjustment(s): Fire Patrol: SA004 Description: FIRE PATROL
 Comments: 20-21: #94 SV, REMOVE SHAPE ADJ / 99-2000; NEW RES @ 75% COMPL, CHECK 1-1-2000, OSD....DOG!!! 05-06: RECALC SETUP;#17

→ 2004 I/O → 2009 M/M

Improvements - Residence / Manufactured Structures

Bldg: 1 Code Area: 04480 Stat Class: 142 Year Blt: 1997 Eff Year Blt: 2009 Sq.Ft: 1976 % Complete: 100
 Desc: Multi Story above grade Dimensions: RMV: 317330
 Func Obsc: 100 Econ %: 100 Other %: 100 Exception: 0 Adjust: Adjust RMV: 0

Floors

Type	Class	Display Group	Floor Size	Beds	Baths	Yr Blt	Eff Yr Blt	Inventory	Exception
First Floor	4	Finished	988	0	FB-1 HB-1	1997	1997	BTH - 1, KIT-, ROOF, HVAC, FP - 1	Exception: Y N
Second Floor	4	Finished	988	3	FB-2	1997	1997	BATH - 2, HVAC	Exception: Y N

First floor 4 F 315 0 0 2024

M/M

Accessories

Description	Class	Size SqFt	Eff Yr Blt	RMV	Quantity	Exception
DECK	4	528	1998	9293	1	Exception: Y N
ROOF EXTENSION OR PATIO COVER	4	528	1998	13475	1	Exception: Y N

change to I/A

I/O

Improvements - Accessory Buildings

Bldg: 2 Code Area: 04480 Stat Class: 321 Year Blt: 2020 Eff Year Blt: 2020 Sq.Ft: 450 % Complete: 100
 Desc: Hay Cover (HC) Dimensions: 18x25 RMV: 4200
 Func Obsc: 100 Econ %: 100 Other %: 100 Exception: 0 Adjust: Adjust RMV: 0

I/O

Floors

Type	Class	Display Group	Floor Size	Beds	Baths	Yr Blt	Eff Yr Blt	Inventory	Exception
Hay Cover	5	Finished	450	0	0	2020	2020	<i>Fai</i>	Exception: Y N

Accessories

Description	Class	Size SqFt	Eff Yr Blt	RMV	Quantity	Exception
CONCRETE DRIVEWAY	5	650	1987	1001	1	Exception: Y N



SKETCH/AREA TABLE ADDENDUM

SUBJECT INFO

File No.: 560142 Parcel No.: 071E34AA00800
 Property Address: 590 LOAR RD SE
 City: Salem County: Marion State: OR ZipCode: 97381
 Owner:
 Client: Client Address:
 Appraiser Name: Inspection Date:

SKETCH

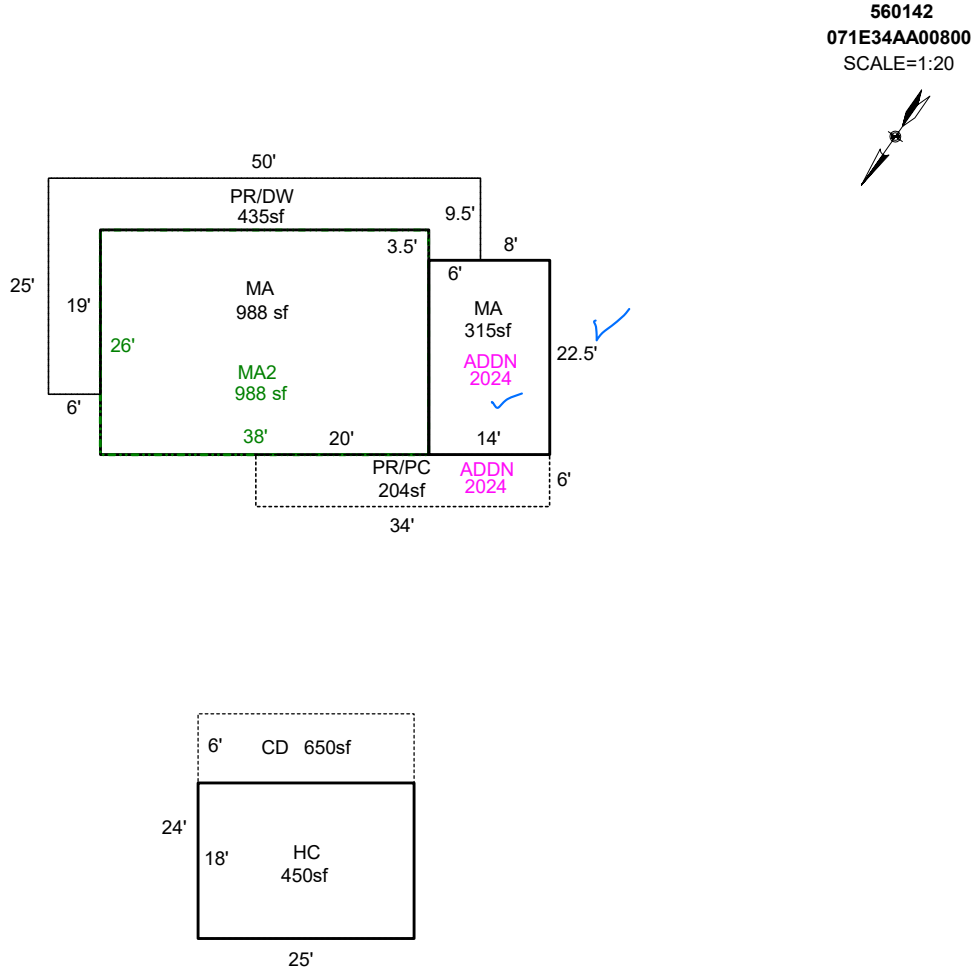

Sketch by ApexSketch

AREA CALCULATIONS SUMMARY

Code	Description	Factor	Net Size	Perimeter	Net Totals
GBA1	HC	1.0	450.0	86.0	450.0
GLA1	MA	1.0	988.0	128.0	
	MA	1.0	315.0	73.0	1303.0
GLA2	MA2	1.0	988.0	128.0	988.0
P/P	CD	1.0	650.0	102.0	
	PR/DW	1.0	0.0	153.5	
	PR/DW	1.0	435.0	157.0	
	PR/PC	1.0	204.0	80.0	1289.0
	Net LIVABLE	cnt	3 (rounded)		2,291
	Net BUILDING	cnt	1 (rounded)		450

COMMENT TABLE 1

DRAWN BY JRONDEMA 7/25/18
 UPD BY PHU 12.16.20: 555-20-004963
 UPDATED BY CJURAN 12/21/2021
 UPDATED BY CLOBERG 08/14/24 24-004072 ADDN

COMMENT TABLE 2

#10 CL 03/11/2021

12/17/24 MLH

COMMENT TABLE 3

TAGS L2

TAGS L1



R60142 NV-NI Shed
2021-03-11 L2



R60142 MA Rear
2021-03-11 L2



R60142 MA Front E End
2021-03-11 L2



R60142 18x25 HC
2021-03-11 L2



R60142 MA S. SIDE
12/31/19



R60142 MA N. SIDE
12/31/19



R60142 MP
12/31/19