

Acct ID: 344074 MTL: 071W130001302 Date: 10/3/24 Appr: MLH Prop Class: 551 RMV Prop Class: 451  
 Situs: 14725 CHRIS WAY NE SILVERTON OR 97381 MaSaNh: 03 06 000 Unit: 49793 Year: 2024  
 Last Date Appraised: 10/12/2022 Appraiser: MATTHEW HAMILTON Retag: Y N Tag info: 2025 - Tags/Permit (Alt Energy System)  
 Owner: HOUTS, KATIE E & HOUTS, DAREN Roll Type: R  
 Cycle Tag Sales Verification Other: \_\_\_\_\_ Inspection level: 1 2 3 4 LCB TTO INSP AV: 808550  
 RMV Land: 429440 RMV Imp: 1556530 RMV Total: 1985970 MAV: 782540 MSAV: 26010 SAV: 67378  
 Comment: 23-24: L2 10.12.22 MLH  
 22-23: CL L2 12/08/21

*new solar @ 100% close Tag*

Input MLH 11/22/24

**Notations**

RP/MS	Code	Description
RP	ZONED	FARM EFU ZONED

*Farm Homesite*

**OSDs**

Count	Code	Description	RMV	Code Area	Exception
1	SAA	SA OSD - AVERAGE	45000	04500	0

**Land**

Site: 1	Code Area: 04500	Size: 6.05 Acres	Use Code: 005	Zone: REST	SAV Use: 011	Exception: 0
Class: 4HD	Value Source: Farm Use - EFU	Description: FOUR HILL DRY	RMV: 334870	Exception: Y	N	
Adjustment(s): VWGR	Fire Patrol:	Description:				
Comments: Liability year - 1974 / 20-21: #94 CYCLE C19, NO CHG / 18-19: PER #94 CHG LAND SCHED / 16-17: #94 SALES VERIF, NO CHG / 14-15: CYCLE WORK PER #31 NO CHG//09-10: ADD VIEW ADJ PER #31// 06-07: RECALC SETUP;#36 08-05-05						
Site: 2	Code Area: 04500	Size: 1.00 Acres	Use Code: 005	Zone: REST	SAV Use: 011	Exception: 0
Class: 4HD	Value Source: Farm Homesite	Description: FOUR HILL DRY	RMV: 49570	Exception: Y	N	
Adjustment(s): VWGR	Fire Patrol:	Description:				
Comments: Liability year - 2022						

**Improvements - Residence / Manufactured Structures**

Bldg: 1 Code Area: 04500 Stat Class: 154 Year Blt: 2021 Eff Year Blt: 2021 Sq.Ft: 8315 % Complete: 100  
 Desc: Multi Story above grade with basement Dimensions: RMV: 1556530  
 Func Obsc: 100 Econ %: 100 Other %: 100 Exception: 0 Adjust: Adjust RMV: 0

*M/C*

**Floors**

Type	Class	Display Group	Floor Size	Beds	Baths	Yr Blt	Eff Yr Blt	Inventory	Exception
First Floor	5	Finished	3635	4	FB-3/ HB-1	2021	2021	BATH - 3, BTH - 1, KIT-, BATH+, ROOF, HVAC, FP - 1	Y N
Attic	5	Finished	1045	0	0	2021	2021	HVAC	Y N
Basement	5	Finished	3635	2	0	2021	2021	HVAC	Y N
Garage Attached	5	Finished	1106	0	0	2021	2021	ROOF	Y N

**Accessories**

Description	Class	Size SqFt	Eff Yr Blt	RMV	Quantity	Exception
YARD IMPROVEMENTS AVERAGE	5	0	2021	37422	1	Y N

**Improvements - Accessory Buildings**

No improvement data available for all other stat class types.

*905 50 2024 \$20,000 Exempt*



# SKETCH/AREA TABLE ADDENDUM

## SUBJECT INFO

File No.: 344074 Parcel No.: 071W13 1302  
 Property Address: 14725 CHRIS WAY NE  
 City: SILVERTON County: Marion State: OR ZipCode: 97381  
 Owner:  
 Client Address:  
 Appraiser Name: Inspection Date:

## SKETCH

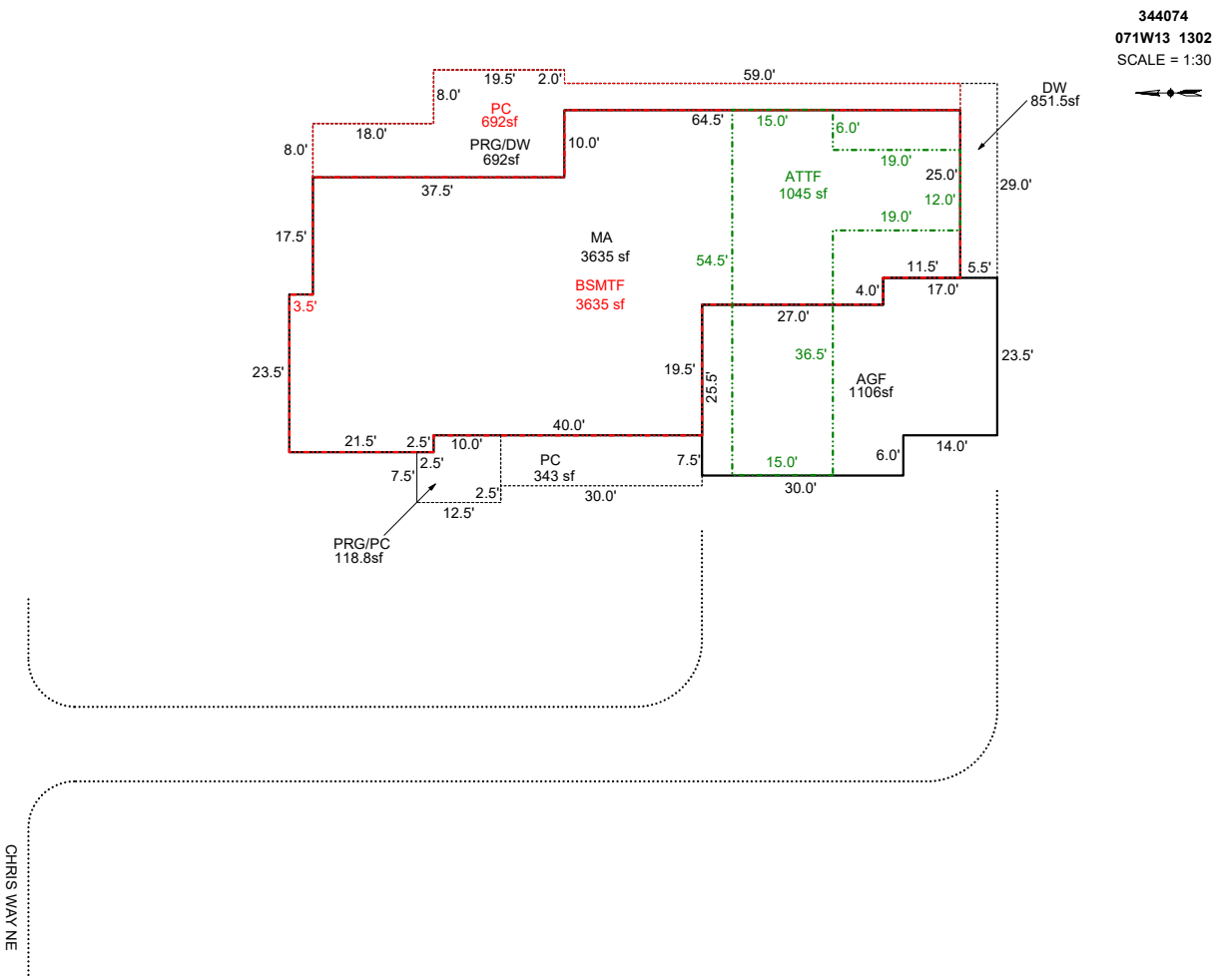

AREA CALCULATIONS SUMMARY						COMMENT TABLE 1	
Code	Description	Factor	Net Size	Perimeter	Net Totals		
GLA1	MA	1.0	3635.8	302.0	3635.8	APEX BY CJURAN 06/28/2021 555-21-002590 UPDATED BY CJURAN 04/12/2022 UPDATED BY CJURAN 03/21/2023 UPDATED BY CLOBERG 10/10/24	
GLA2	ATTF	1.0	1045.5	177.0	1045.5		
BSMT	BSMTF	1.0	3635.8	302.0	3635.8		
GAR	AGF	1.0	1106.0	147.0	1106.0		
P/P	PRG/PC	1.0	118.8	45.0			
	PRG/DW	1.0	692.0	225.0			
	DW	1.0	851.5	286.0			
	PC	1.0	343.8	105.0			
	PC	1.0	692.0	225.0	2698.0		
	Net LIVABLE	cnt	2 (rounded)		4,681		

COMMENT TABLE 2	COMMENT TABLE 3
#10 CL 12/08/2021 MLH 10/12/2022 MLH 10/03/24	TAGS L2 TAGS L2 TAGS L2

# SKETCH/AREA TABLE ADDENDUM

## SUBJECT INFO

File No.: 344074 Parcel No.: 071W13 1302  
 Property Address: 14725 CHRIS WAY NE  
 City: SILVERTON County: State: OR ZipCode: 97381  
 Owner:  
 Client: Client Address:  
 Appraiser Name: Inspection Date:

## SKETCH

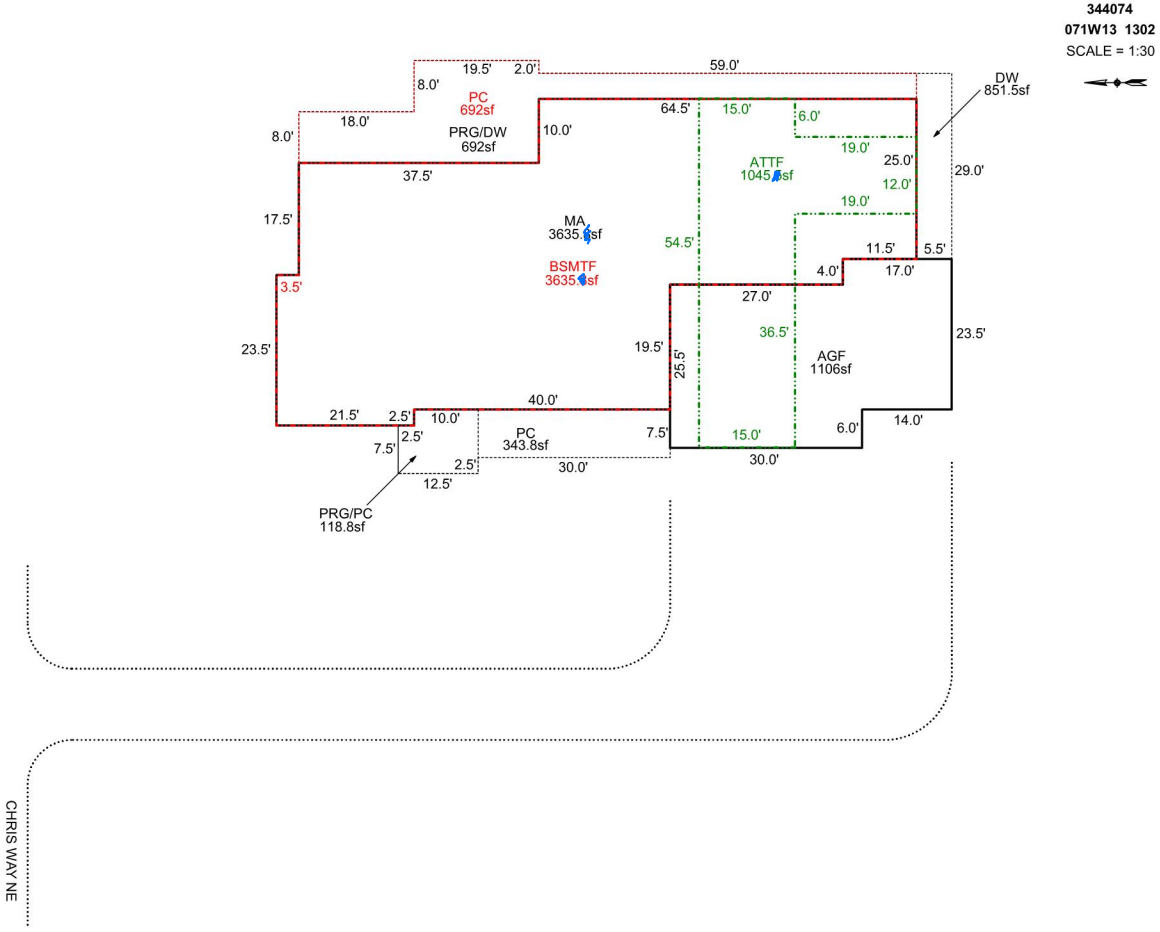

Sketch by Apex Sketch

### AREA CALCULATIONS SUMMARY

Code	Description	Factor	Net Size	Perimeter	Net Totals
GLA1	MA	1.0	3635.8	302.0	3635.8
GLA2	ATTF	1.0	1045.5	177.0	1045.5
BSMT	BSMTF	1.0	3635.8	302.0	3635.8
GAR	AGF	1.0	1106.0	147.0	1106.0
P/P	PRG/PC	1.0	118.8	45.0	
	PRG/DW	1.0	692.0	225.0	
	DW	1.0	851.5	286.0	
	PC	1.0	343.8	105.0	
	PC	1.0	692.0	225.0	2698.0
	Net LIVABLE	cnt	2 (rounded)		4,681

### COMMENT TABLE 1

APEX BY CJURAN 06/28/2021 555-21-002590  
 UPDATED BY CJURAN 04/12/2022  
 UPDATED BY CJURAN 03/21/2023

### COMMENT TABLE 2

#10 CL 12/08/2021  
 MLH 10/12/2022

*MLH 10/3/24*

### COMMENT TABLE 3

TAGS L2  
 TAGS L2

*TAGS L2*



344074 Westerly View- (1)  
2021-10-04 L2



344074 MA- (2)  
2021-10-04 L2



344074 Westerly View- (3)  
2021-10-04 L2



344074 MA- (1)  
2021-10-04 L2



344074 Westerly View- (2)  
2021-10-04 L2





344074 MA Front- (3)  
2021-12-08 L2



344074 MA S End  
2021-12-08 L2



344074 MA-AGF Front N End- (2)  
2021-12-08 L2



344074 MA Front- (2)  
2021-12-08 L2



344074 MA Rear S End (2)  
2021-12-08 L2



344074 MA-AGF Front N End- (1)  
2021-12-08 L2



344074 MA Front- (1)  
2021-12-08 L2



344074 MA Rear S End (1)  
2021-12-08 L2



344074 MA View-Rear  
2021-12-08 L2



344074 MA-Rear PRG  
2021-12-08 L2



344074 MA-AGF Front N End- (3)  
2021-12-08 L2