

Acct ID: 329045 MTL: 082W02BB00900 Date: **10-9-24** Appr: **Gene** Prop Class: 401 RMV Prop Class: 401
 Situs: 1982 PEBBLES LN SE SALEM OR 97317 MaSaNh: 01 06 004 Unit: 27161 **INPUT 11-15-24** Year: 2024

Last Date Appraised: 09/19/2019 Appraiser: CLINT LUKE Retag: Y N Tag info: 2025 - Tags/Permit (Additional) **Gene**
 Owner: MCCARTHY,EVA SONG & MCCARTHY,SEAN JAMES Roll Type: R
 Cycle: **Tag** Sales Verification Other: _____ Inspection level: 1 2 3 **4** LCB TTO INSP AV: 391260
 RMV Land: 240220 RMV Imp: 530830 RMV Total: 771050 MAV: 391260 MSAV: 0 SAV: 0
 Comment:

Notations **24-006110 23x30 Pmt. Cover FINAL**
 No notation data available.

PART OF Y1 10/15/24

OSDs

| Count | Code | Description | RMV | Code Area | Exception |
|-------|------|-------------|-------|-----------|-----------|
| 1 | MKTF | OSD - FAIR | 35000 | 92410 | 0 |

Land

Site: 1 Code Area: 92410 Size: 1.50 Acres Use Code: 004 Zone: NREST SAV Use: Exception: 0
 Class: Value Source: **Rural at MKT** Description: RMV: 205220 Exception: Y N
 Adjustment(s): **2BDSS** Fire Patrol: Description:
 Comments: 02-03: REAPPRAISAL

Improvements - Residence / Manufactured Structures

Bldg: 1 Code Area: 92410 Stat Class: 142 Year Blt: 2003 Eff Year Blt: 2003 Sq.Ft: 2728 % Complete: 100
 Desc: Multi Story above grade Dimensions: RMV: 506720
 Func Obsc: 100 Econ %: 100 Other %: 100 Exception: 0 Adjust: Adjust RMV: 0

Floors

| Type | Class | Display Group | Floor Size | Beds | Baths | Yr Blt | Eff Yr Blt | Inventory | Exception |
|-----------------|-------|---------------|------------|------|---------------|--------|------------|--|----------------|
| First Floor | 4 | Finished | 1968 | 3 | FB-2/ HB-1 | 2003 | 2003 | BATH - 2, BTH - 1, KIT+, BATH+, ROOF HVAC+ | Exception: Y N |
| Attic | 4 | Finished | 760 | 0 | 0 | 2003 | 2003 | HVAC+ AVS AVB | Exception: Y N |
| Garage Attached | 4 | Finished | 1166 | 0 | 0 | 2003 | 2003 | ROOF | Exception: Y N |

Accessories

| Description | Class | Size SqFt | Eff Yr Blt | RMV | Quantity | Exception |
|-------------------------------|-------|-----------|------------|------|----------|----------------|
| CONCRETE DRIVEWAY Y14G | 4 | 774 | 2003 | 2264 | 1 | Exception: Y N |
| PATIO | 4 | 258 | 2003 | 1277 | 1 | Exception: Y N |
| PATIO | 4 | 637 | 2003 | 3153 | 1 | Exception: Y N |
| ROOF EXTENSION OR PATIO COVER | 4 | 153 | 2003 | 3993 | 1 | Exception: Y N |
| ROOF EXTENSION OR PATIO COVER | 4 | 258 | 2003 | 6734 | 1 | Exception: Y N |

Improvements - Accessory Buildings

Bldg: 2 Code Area: 92410 Stat Class: 351 Year Blt: 2005 Eff Year Blt: 2005 Sq.Ft: 1440 % Complete: 100
 Desc: General Purpose Building (GB) Dimensions: 40x36 RMV: 11610
 Func Obsc: 100 Econ %: 100 Other %: 100 Exception: 0 Adjust: Adjust RMV: 0

Floors

| Type | Class | Display Group | Floor Size | Beds | Baths | Yr Blt | Eff Yr Blt | Inventory | Exception |
|----------------------|-------|---------------|------------|------|-------|--------|------------|------------|-----------------------|
| General Purpose Bldg | 4 | Finished | 1440 | 0 | 0 | 2005 | 2005 | AVB | Exception: Y N |

Accessories

| Description | Class | Size SqFt | Eff Yr Blt | RMV | Quantity |
|-----------------------------|-------|-----------|------------|-----|----------|
| No accessory data available | | | | | |

Bldg: 4 Code Area: 92410 Stat Class: 905 Year Blt: 2019 Eff Year Blt: 2019 Sq.Ft: 0 % Complete: 100
 Desc: Rural Solar Panel/Array Dimensions: RMV: 12500
 Func Obsc: 100 Econ %: 100 Other %: 100 Exception: 0 Adjust: Adjust RMV: 0

Floors

| Type | Class | Display Group | Floor Size | Beds | Baths | Yr Blt | Eff Yr Blt | Inventory |
|-------------------------|-------|---------------|------------|------|-------|--------|------------|-----------|
| No floor data available | | | | | | | | |

Accessories

| Description | Class | Size SqFt | Eff Yr Blt | RMV | Quantity |
|-----------------------------|-------|-----------|------------|-----|----------|
| No accessory data available | | | | | |

SKETCH/AREA TABLE ADDENDUM

SUBJECT INFO

File No.: 329045 Parcel No.: 082W02BB00900
 Property Address: 1982 PEBBLES LN SE
 City: Salem County: Marion State: OR ZipCode: 97317
 Owner:
 Client: Client Address:
 Appraiser Name: Inspection Date:

SKETCH

329045
082W02BB00900
SCALE=1:30

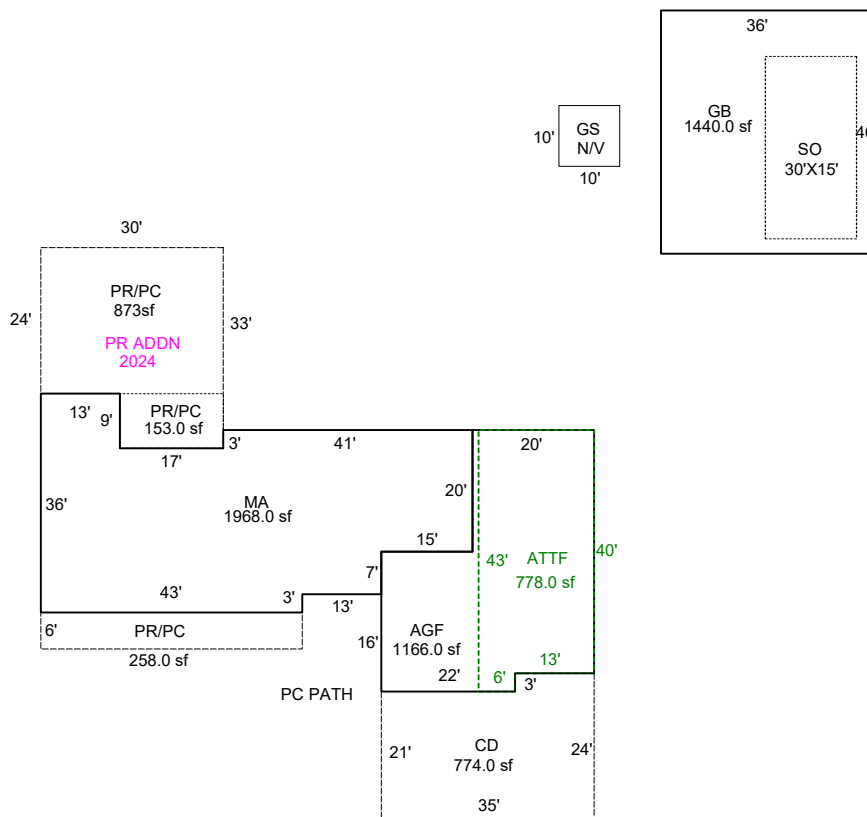

Sketch by ApexSketch

| AREA CALCULATIONS SUMMARY | | | | | | COMMENT TABLE 1 | |
|---------------------------|--------------|--------|----------|-----------|------------|---|--|
| Code | Description | Factor | Net Size | Perimeter | Net Totals | | |
| GBA1 | GB | 1.0 | 1440.0 | 152.0 | 1440.0 | APEXED BY NRC 06/08/2009 UPDATED BY JRONDEMA 7/3/17 UPD BY PH 10.21.19 UPDATED BY CLOBERG 09/20/24 24-006110 PR ADDN | |
| GLA1 | MA | 1.0 | 1968.0 | 220.0 | 1968.0 | | |
| GLA2 | ATTF | 1.0 | 778.0 | 124.0 | 778.0 | | |
| GAR | AGF | 1.0 | 1166.0 | 156.0 | 1166.0 | | |
| YI1 | CD | 1.0 | 774.0 | 118.0 | | | |
| | PR/PC | 1.0 | 258.0 | 98.0 | | | |
| | PR/PC | 1.0 | 873.0 | 126.0 | 1905.0 | | |
| | Net LIVABLE | cnt | 2 | (rounded) | 2,746 | | |
| | Net BUILDING | cnt | 1 | (rounded) | 1,440 | | |

| COMMENT TABLE 2 | COMMENT TABLE 3 |
|---|-----------------|
| 5.19.17 SR #94 CYCLE, NV 09.19.19 SR #94 | S.V. |