

Acct ID: 326994 MTL: 071E06D002100 Date: 12/4/24 Appr: MLH Prop Class: 401 RMV Prop Class: 401  
 Situs: 15932 STORMY DR NE SILVERTON OR 97381 MaSaNh: 03 06 000 Unit: 60702 Year: 2024  
 Last Date Appraised: 08/28/2023 Appraiser: MATTHEW HAMILTON Retag: Y N Tag info: 2025 - Tags/Permit (Alt Energy System)  
 Owner: WEBB, KATHALYNNE N Roll Type: R  
 Cycle Tag Sales Verification Other: \_\_\_\_\_ Inspection level: 1 2 3 4 LCB TTO INSP AV: 389440  
 RMV Land: 245160 RMV Imp: 705270 RMV Total: 950430 MAV: 389440 MSAV: 0 SAV: 0  
 Comment: 24-25 L4 8/28/23 CLUKE  
 23-24 L2 12/13/22 CLUKE  
 22-23 L4 6.8.21 CL10

*Replacement solar @ 100%  
 update inventory Retag for Hardship  
 conversion in 6-3-26*

Notations  
 No notation data available.

OSDs

Count	Code	Description	RMV	Code Area	Exception	Input MLH 12/31/24
1	MKTA	OSD - AVERAGE	45000	04500	0	

Land

Site: 1 Code Area: 04500 Size: 1.55 Acres Use Code: 004 Zone: NREST SAV Use: Exception: 0  
 Class: 6B Value Source: Rural at MKT Description: SIX BENCH RMV: 200160 Exception: Y N  
 Adjustment(s): FSOIL Fire Patrol: Description:  
 Comments: 24-25: ADD SOILS  
 0040028 01-02: F01-0020 CREATION OF NEW SUB, BERRY MEADOWS 06-07: RECALC SETUP;#10, 06-20-05

Improvements - Residence / Manufactured Structures

Bldg: 1 Code Area: 04500 Stat Class: 152 Year Blt: 2006 Eff Year Blt: 2006 Sq.Ft: 2564 % Complete: 100  
 Desc: Multi Story above grade Dimensions: RMV: 642630  
 Func Obsc: 100 Econ %: 100 Other %: 100 Exception: 0 Adjust: Adjust RMV: 0

Floors

Type	Class	Display Group	Floor Size	Beds	Baths	Yr Blt	Eff Yr Blt	Inventory	Exception: Y N
First Floor	5	Finished	2102	3	FB-2/ HB-1	2006	2006	BATH - 2, BTH - 1, KIT, HVAC+, ROOF	Y N
Attic	5	Finished	462	0	0	2006	2006	HVAC+	Y N
Garage Attached	5	Finished	990	0	0	2006	2006	ROOF	Y N

Accessories

Description	Class	Size SqFt	Eff Yr Blt	RMV	Quantity	Exception: Y N
YARD IMPROVEMENTS AVERAGE	5	0	2006	34776	1	Y N

Improvements - Accessory Buildings

Bldg: 2 Code Area: 04500 Stat Class: 351 Year Blt: 2009 Eff Year Blt: 2016 Sq.Ft: 2880 % Complete: 100  
 Desc: General Purpose Building (GB) Dimensions: 48x40 RMV: 56140  
 Func Obsc: 100 Econ %: 100 Other %: 100 Exception: 0 Adjust: 24,440 Adjust RMV: 0

Floors

Type	Class	Display Group	Floor Size	Beds	Baths	Yr Blt	Eff Yr Blt	Inventory	Exception: Y N
General Purpose Bldg	5	Finished	1920	0	0	2009	2016	AVG	Y N
General Purpose Bldg	5	Finished	960	0	0	2009	2016		Y N

Accessories

Description	Class	Size SqFt	Eff Yr Blt	RMV	Quantity	Exception: Y N
No accessory data available						

Bldg: 4 Code Area: 04500 Stat Class: 905 Year Blt: 2011 Eff Year Blt: 2011 Sq.Ft: 0 % Complete: 100  
 Desc: Rural Solar Panel/Array Dimensions: RMV: 6500  
 Func Obsc: 100 Econ %: 100 Other %: 100 Exception: 0 Adjust: Adjust RMV: 0  
201,000

Floors

Type	Class	Display Group	Floor Size	Beds	Baths	Yr Blt	Eff Yr Blt	Inventory	Exception: Y N
No floor data available									

Accessories

Description	Class	Size SqFt	Eff Yr Blt	RMV	Quantity	Exception: Y N
No accessory data available						



# SKETCH/AREA TABLE ADDENDUM

## SUBJECT INFO

File No.: 326994 Parcel No.: 071E06D 02100  
 Property Address: 05932 STORMY DRIVE NE  
 City: SILVERTON County: State: OR ZipCode: 97381  
 Owner:  
 Client: Client Address:  
 Appraiser Name: Inspection Date:

## SKETCH

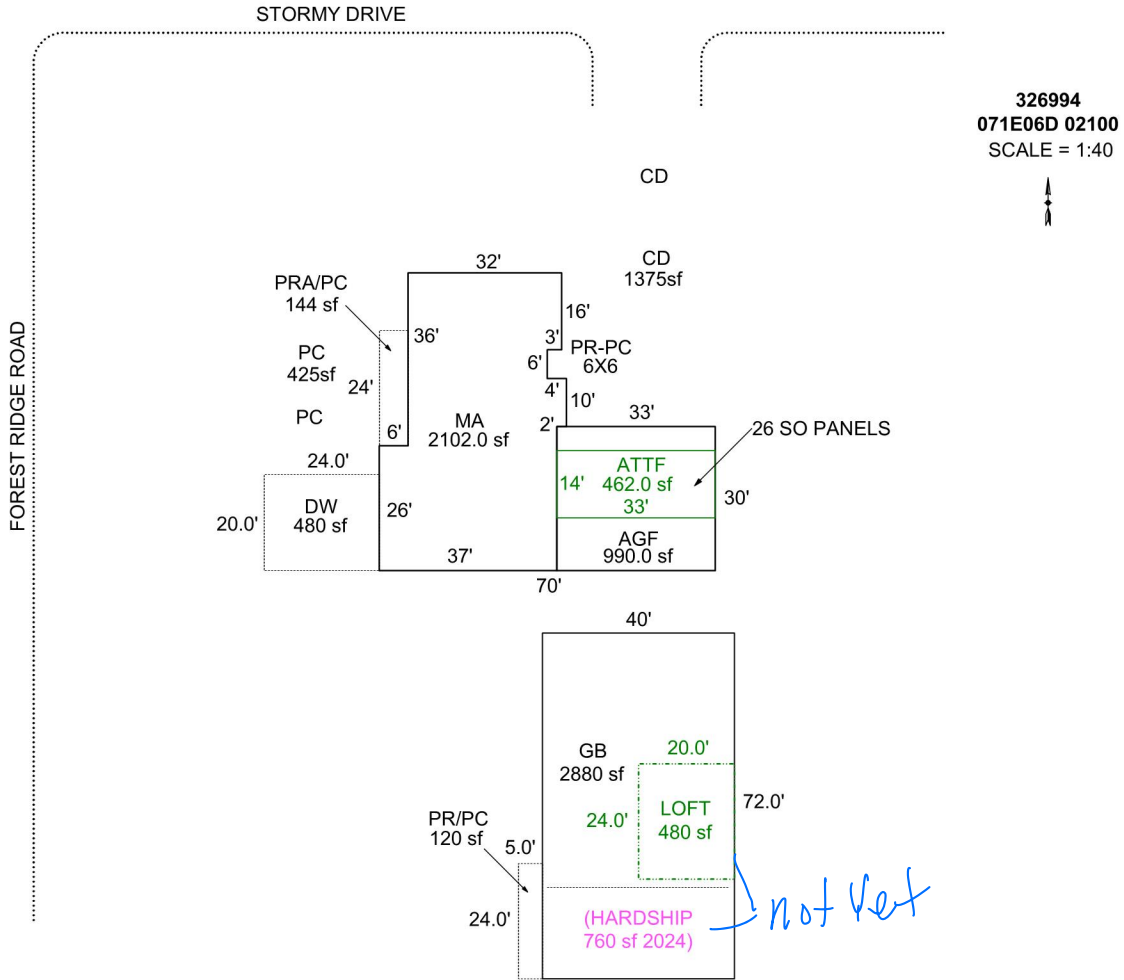

Sketch by Apex Sketch

### AREA CALCULATIONS SUMMARY

Code	Description	Factor	Net Size	Perimeter	Net Totals
GBA2	LOFT	1.0	480.0	88.0	480.0
GLA1	MA	1.0	2102.0	208.0	2102.0
GLA2	ATTF	1.0	462.0	94.0	462.0
GAR	AGF	1.0	990.0	126.0	990.0
OTH	GB	1.0	2880.0	224.0	2880.0
P/P	PRA/PC	1.0	144.0	60.0	
	DW	1.0	480.0	88.0	
	PR/PC	1.0	120.0	58.0	744.0
	Net LIVABLE	cnt	2 (rounded)		2,564
	Net BUILDING	cnt	1 (rounded)		480

### COMMENT TABLE 1

APEXED BY NRC 11/12/2009  
 added dw 1/12/10 Jane  
 Edit to add SO 5/8/12 Jane  
 UPDATED BY CJURAN 02/15/2022  
 UPDATED BY CJURAN 04/20/2022 555-21-009794  
 UPDATED BY CJURAN 09/18/2023  
 UPDATED BY CJURAN 01/08/2024 23-003474

### COMMENT TABLE 2

#10 CL 06/08/2021  
 CL 08/28/2023

### COMMENT TABLE 3

SV L4  
 TAG L4

12/4/24 MCH TAGS L3