

SKETCH/AREA TABLE ADDENDUM

SUBJECT INFO

File No.: 105047 Parcel No.: 081W34CD00200
 Property Address: 353 SW DIVISION ST
 City: SUBLIMITY County: State: OR ZipCode: 97385
 Owner:
 Client: Client Address:
 Appraiser Name: Inspection Date:

SKETCH

105047
081W34CD00200

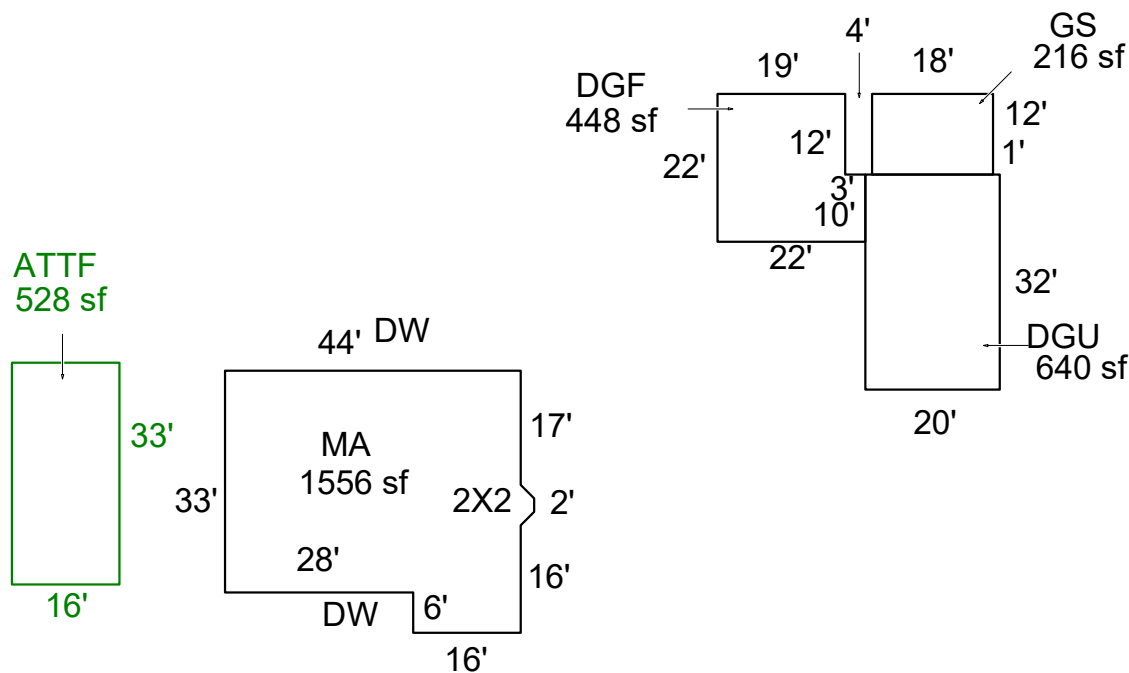

Sketch by ApexSketch

AREA CALCULATIONS SUMMARY						COMMENT TABLE 1	
Code	Description	Factor	Net Size	Perimeter	Net Totals		
GLA1	MA	1.0	1556.0	167.7	1556.0	Drawn by vwiegand 3/15/11 UPDATED BY LK 7-22-21 UPDATED BY LK 12.17.24	
GLA2	ATTF	1.0	528.0	98.0	528.0		
GAR	DGU	1.0	640.0	104.0	640.0		
OTH	GS	1.0	216.0	60.0	216.0		
						COMMENT TABLE 2	COMMENT TABLE 3
						CYCLE 72 6-9-21 12-3-24 TAG GM	
Net LIVABLE		cnt	1	(rounded)	2,084		