

Acct ID: 563381 MTL: 082W02D000901 Date: **9-26-24** Appr: **once** Prop Class: 401 RMV Prop Class: 401
 Situs: 8129 PUDDING CREEK DR SE SALEM OR 97317 MaSaNh: 01 06 004 Unit: 115385 Year: 2024
 Last Date Appraised: 06/15/2023 Appraiser: CLINT LUKE Retag: Y **N** Tag info: 2025 - Tags/Permit (with Energy System)
 Owner: WEBBER, NATHAN L Roll Type: R
 Cycle: **1a** Sales Verification Other: _____ Inspection level: 1 2 3 **4** LCB TTO INSP AV: 401160
 RMV Land: 240690 RMV Imp: 374540 RMV Total: 615230 MAV: 401160 MSAV: 0 SAV: 0
 Comment: 23-24: GRH L4 6/15/23

INPUT 11/13/24 once

Notations **24-00467 SOUTH \$5300**

OSDs

Count	Code	Description	RMV	Code Area	Exception
1	MKTF	OSD - FAIR	35000	92410	0

Land

Site: 1 Code Area: 92410 Size: 1.51 Acres Use Code: 004 Zone: NREST SAV Use: Exception: 0
 Class: 4BDS Value Source: Rural at MKT Description: **FOUR BENCH DRY SPECIAL SOUTH** RMV: 205690 Exception: Y N
 Adjustment(s): Fire Patrol: Description:
 Comments: 17-18: CYCLE WORK #94 CHG OSD// 2002-03 REAPPRAISAL; 2003-04 MODIFIED LAND TABLE KKB65 10/02

Improvements - Residence / Manufactured Structures

Bldg: 1 Code Area: 92410 Stat Class: 141 Year Blt: 1992 Eff Year Blt: 1992 Sq.Ft: 1931 % Complete: 100
 Desc: One Story Only Dimensions: RMV: 364570
 Func Obsc: 100 Econ %: 100 Other %: 100 Exception: 0 Adjust: Adjust RMV: 0

Floors

Type	Class	Display Group	Floor Size	Beds	Baths	Yr Blt	Eff Yr Blt	Inventory	Exception
First Floor	4	Finished	1931	3	FB-2	1992	1992	BATH - 2, KIT, ROOF, VAC+, FP - 1	Y N
Garage Attached	4	Finished	690	0	0	1992	1992	ROOF	Y N

Accessories

Description	Class	Size SqFt	Eff Yr Blt	RMV	Quantity	Exception
YARD IMPROVEMENTS AVERAGE	4	1	1992	23715	1	Y N

Bldg: 2 Code Area: 92410 Stat Class: 108 Year Blt: 1992 Eff Year Blt: 1992 Sq.Ft: 0 % Complete: 100
 Desc: Residential Other Improvements Dimensions: RMV: 8970
 Func Obsc: 100 Econ %: 100 Other %: 100 Exception: 0 Adjust: Adjust RMV: 0

Floors

Type	Class	Display Group	Floor Size	Beds	Baths	Yr Blt	Eff Yr Blt	Inventory	Exception
No floor data available									

Accessories

Description	Class	Size SqFt	Eff Yr Blt	RMV	Quantity	Exception
ASPHALT DRIVEWAY	1	2884	1992	7354	1	Y N

Improvements - Accessory Buildings

Bldg: 3 Code Area: 92410 Stat Class: 341 Year Blt: 1960 Eff Year Blt: 1960 Sq.Ft: 220 % Complete: 100
 Desc: Multi Purpose Shed (MP) Dimensions: 20x11 RMV: 820
 Func Obsc: 100 Econ %: 100 Other %: 100 Exception: 0 Adjust: Adjust RMV: 0

Floors

Type	Class	Display Group	Floor Size	Beds	Baths	Yr Blt	Eff Yr Blt	Inventory	Exception
Multi-Purpose Bldg	6	Finished	220	0	0	1960	1960	1999 FRN 50%	Y N

Accessories

Description	Class	Size SqFt	Eff Yr Blt	RMV	Quantity	Exception
No accessory data available						

Bldg: 4 Code Area: 92410 Stat Class: 354 Year Blt: 1960 Eff Year Blt: 1960 Sq.Ft: 220 % Complete: 100
 Desc: Lean-to Light (LTL) Dimensions: RMV: 180
 Func Obsc: 100 Econ %: 100 Other %: 100 Exception: 0 Adjust: Adjust RMV: 0

Floors

50%

Type	Class	Display Group	Floor Size	Beds	Baths	Yr Blt	Eff Yr Blt	Inventory
Lean-to Light Duty	4	Finished	220	0	0	1960	1960	Exception: Y N
Accessories								
Description	Class	Size SqFt	Eff Yr Blt	RMV	Quantity			
No accessory data available								

1999

SKETCH/AREA TABLE ADDENDUM

SUBJECT INFO

File No.: 563381 Parcel No.: 082W02D 00901
 Property Address: 8129 PUDDING CREEK DR SE
 City: SALEM County: MARION State: OR ZipCode: 97317
 Owner:
 Client: Client Address:
 Appraiser Name: Inspection Date:

SKETCH

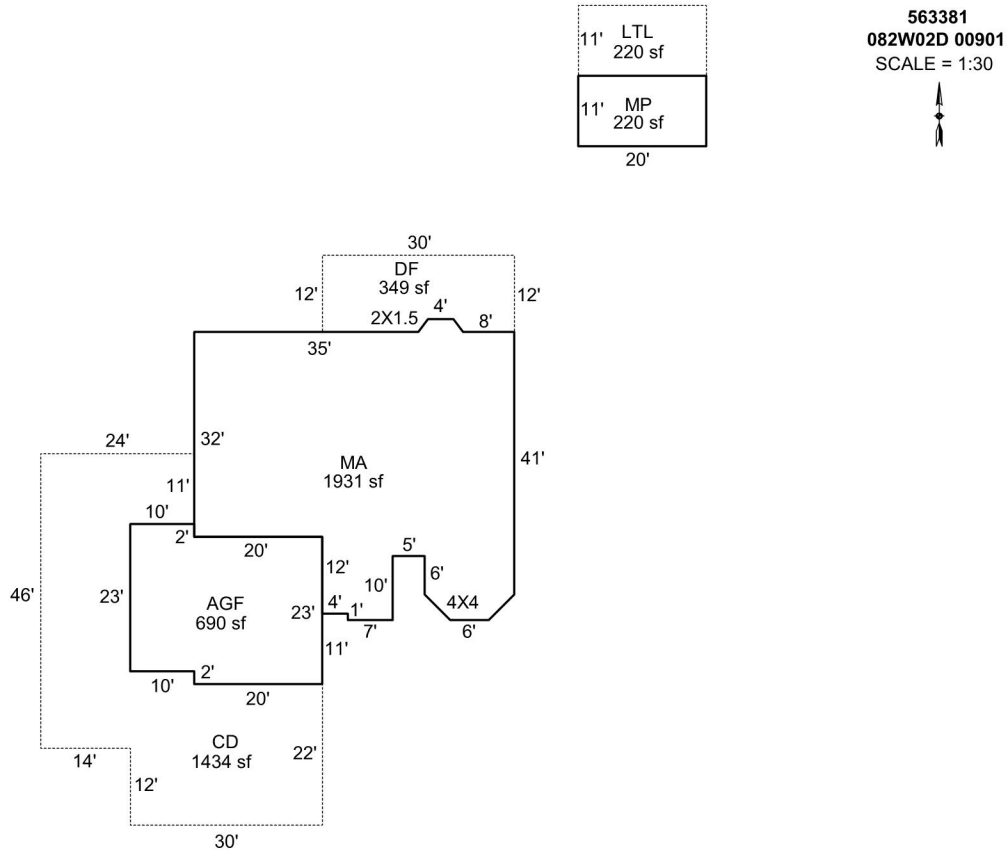

Sketch by Apex Sketch

AREA CALCULATIONS SUMMARY

Code	Description	Factor	Net Size	Perimeter	Net Totals
GBA1	MP	1.0	220.0	62.0	
	LTL	1.0	220.0	62.0	440.0
GLA1	MA	1.0	1931.0	207.3	1931.0
GAR	AGF	1.0	690.0	110.0	690.0
P/P	CD	1.0	1434.0	224.0	
	DF	1.0	349.0	86.0	1783.0

COMMENT TABLE 1

APEXED BY NRC 06/19/2009
 UPDATED BY JRONDEMA 7/10/17
 UPDATED BY CJURAN 06/29/2023

COMMENT TABLE 2

5.18.17 SR #94 CYCLE NV
 GRH 06/15/2023

COMMENT TABLE 3

SV L4

Net LIVABLE	cnt	1	(rounded)	1,931
Net BUILDING	cnt	2	(rounded)	440

Done 9.26.24
 TAGS L4