

Acct ID: 563221 MTL: 082W13C005500 Date: **9-27-24** Appr: **LUKE** Prop Class: 401 RMV Prop Class: 401
 Situs: 9003 SHAW SQ SE AUMSVILLE OR 97325 MaSaNh: 01 06 000 Unit: 112354 Year: 2024
 Last Date Appraised: 05/16/2019 Appraiser: CLINT LUKE Retag: **Y** Tag info: 2025 - Tags/Permit (Alt Energy System)
 Owner: NAUGLE, DOUGLAS L & NAUGLE, CARISSA J Roll Type: R
 Cycle: **Tag** Sales Verification Other: _____ Inspection level: 1 2 3 LCB TTO INSP AV: 392190
 RMV Land: 348080 RMV Imp: 397420 RMV Total: 745500 MAV: 392190 MSAV: 0 SAV: 0
 Comment:

INPUT 11-14-24 LUKE

Notations **23-010428 SOLAR FINALED 4-26-24**
 No notation data available. **\$ 9100**

OSDs

Count	Code	Description	RMV	Code Area	Exception
1	MKTA	OSD - AVERAGE	45000	05558	0

Land

Site: 1 Code Area: 05558 Size: 4.66 Acres Use Code: 004 Zone: NREST SAV Use: Exception: 0
 Class: Value Source: Rural at MKT Description: **2BDSS** RMV: 303080 Exception: Y N
 Adjustment(s): **GOOD** Fire Patrol: Description:
 Comments: 00-01; COMBINED LAND SEGMENTS, NO SPECIAL ASSESSMENT, CORRECTED ACREAGE 2002-03 REAPPRAISAL.

Improvements - Residence / Manufactured Structures

Bldg: 1 Code Area: 05558 Stat Class: 141 Year Blt: 1973 Eff Year Blt: 1985 Sq.Ft: 2363 % Complete: 100
 Desc: One Story Only Dimensions: RMV: 339630
 Func Obsc: 100 Econ %: 100 Other %: 100 Exception: 0 Adjust: Adjust RMV: 0

Floors

Type	Class	Display Group	Floor Size	Beds	Baths	Yr Blt	Eff Yr Blt	Inventory	Exception
First Floor	4	Finished	2363	3	FB-2	1973	1985	BATH - 2, KIT, WA, 1, ROOF	Y N
Garage Attached	4	Low Cost	420	0	0	1973	1985	ROOF	Y N

Accessories

Description	Class	Size SqFt	Eff Yr Blt	RMV	Quantity
No accessory data available					

Bldg: 4 Code Area: 05558 Stat Class: 107 Year Blt: Eff Year Blt: Sq.Ft: 0 % Complete: 100
 Desc: Yard Improvements Dimensions: RMV: 44840
 Func Obsc: 100 Econ %: 100 Other %: 100 Exception: 0 Adjust: Adjust RMV: 0

Floors

Type	Class	Display Group	Floor Size	Beds	Baths	Yr Blt	Eff Yr Blt	Inventory	Exception
No floor data available									

Accessories

Description	Class	Size SqFt	Eff Yr Blt	RMV	Quantity
YARD IMPROVEMENTS EXCELLENT		0	0	36750	1

Improvements - Accessory Buildings

Bldg: 2 Code Area: 05558 Stat Class: 341 Year Blt: 1975 Eff Year Blt: 1975 Sq.Ft: 325 % Complete: 100
 Desc: Multi Purpose Shed (MP) Dimensions: 25x13 RMV: 1090
 Func Obsc: 100 Econ %: 100 Other %: 100 Exception: 0 Adjust: Adjust RMV: 0

Floors

Type	Class	Display Group	Floor Size	Beds	Baths	Yr Blt	Eff Yr Blt	Inventory	Exception
Multi-Purpose Bldg	4	Finished	325	0	0	1975	1975	MP	Y N

Accessories

Description	Class	Size SqFt	Eff Yr Blt	RMV	Quantity
No accessory data available					

Bldg: 3 Code Area: 05558 Stat Class: 351 Year Blt: 1997 Eff Year Blt: 1997 Sq.Ft: 864 % Complete: 100
 Desc: General Purpose Building (GB) Dimensions: 36x24 RMV: 8430
 Func Obsc: 100 Econ %: 100 Other %: 100 Exception: 0 Adjust: Adjust RMV: 0

Floors

Type	Class	Display Group	Floor Size	Beds	Baths	Yr Blt	Eff Yr Blt	Inventory	Exception
No floor data available									

AVG 70%

SKETCH/AREA TABLE ADDENDUM

SUBJECT INFO

File No.: 563221 Parcel No.: 082W13C 05500
 Property Address: 9003 SHAW SQ SE
 City: Aumsville County: State: OR ZipCode: 97325
 Owner:
 Client: Client Address:
 Appraiser Name: Inspection Date:

SKETCH

563221
082W13C 05500
 Scale=1:30

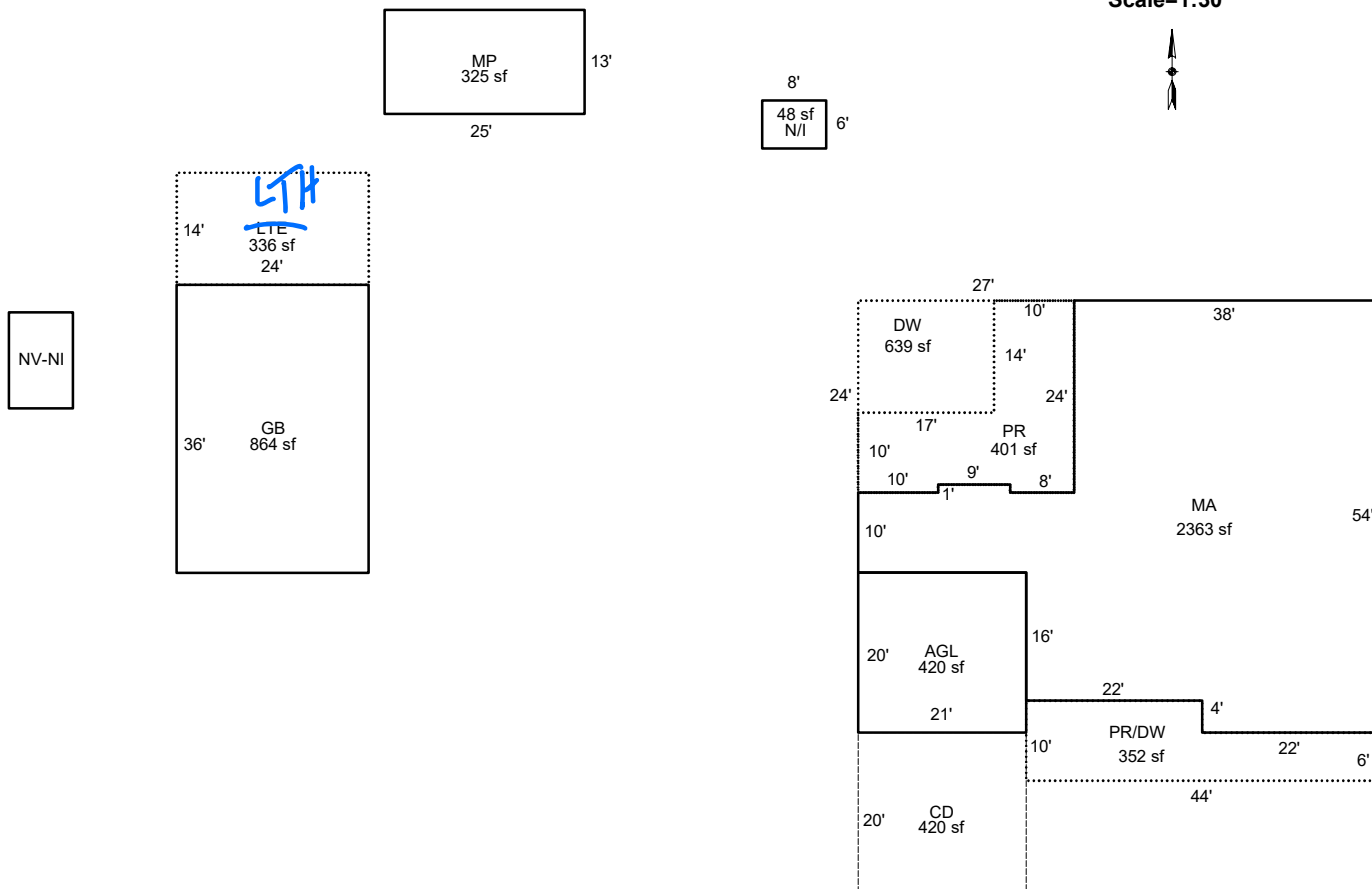

Sketch by ApexSketch

AREA CALCULATIONS SUMMARY

Code	Description	Factor	Net Size	Perimeter	Net Totals
GBA1	MP	1.0	325.0	76.0	
	GB	1.0	864.0	120.0	1189.0
GBA2	MP	1.0	48.0	28.0	48.0
GBA3	LTE	1.0	336.0	76.0	336.0
DW	PR/DW	1.0	352.0	108.0	
	DW	1.0	639.0	104.0	991.0
GAR	AGL	1.0	420.0	82.0	420.0
MA	MA	1.0	2363.0	240.0	2363.0
P/P	CD	1.0	420.0	82.0	420.0
PR	PR	1.0	401.0	104.0	401.0

COMMENT TABLE 1

APEXED BY NRC 07/16/2009
 UPDATED BY CHRIS 5/24/19
 UPDATED BY CLOBERG 10/28/24

COMMENT TABLE 2

CLUKE 09/27/24

COMMENT TABLE 3

TAGS SOLAR L4

Net BUILDING cnt 4 (rounded) 1,573