

Acct ID: 559986 MTL: 063W24B000100 Date: **10/11/24** Appr: **GRH** Prop Class: 551 RMV Prop Class: 551
 Situs: 8390 ORLANDO LN NE KEIZER OR 97303 MaSaNh: 04 06 002 Unit: 138157 Year: 2024

Last Date Appraised: 09/14/2011 Appraiser: GERARDO RAMIREZ HERNANDEZ Retag: **0** N Tag info: 2025 - NEW CONSTRUCTION (Outbuilding)
Recheck For farm USE L3

Owner: CLAUDIA R MIKESKA LT Roll Type: R
 Cycle: **Tag** Sales Verification Other: _____ Inspection level: 1 2 3 4 LCB **0** TTC **0** INSP AV: 524371
 RMV Land: 458980 RMV Imp: 817180 RMV Total: 1276160 MAV: 491360 MSAV: 33011 SAV: 81882

Comment: **971 218 2476 Brett made Appt; dogs on property**

Add LTL o.m.s, update inv

Notations

RP/MS	Code	Description
RP	ZONED	FARM EFU ZONED

3 cows, Hay FarmUSE

OSDs

Count	Code	Description	RMV	Code Area	Exception
1	SAA	SA OSD - AVERAGE	45000	92410	0
1	SPSA	SA SEPTIC	12000	92410	0

Chris 11/19/24

Land

Site: 2 Code Area: 92410 Size: 1.00 Acres Use Code: 005 Zone: REST SAV Use: 011 Exception: 0
 Class: **2bd** Value Source: Farm Homesite Description: RMV: 34250 Exception: Y N
 Adjustment(s): GSOIL, IRR Fire Patrol: Description:
 Comments: Liability year - 2009 / 2400210

Site: 3 Code Area: 92410 Size: 3.80 Acres Use Code: 005 Zone: REST SAV Use: 011 Exception: 0
 Class: **2B** Value Source: Farm Use - EFU **4.4 AC** Description: TWO BENCH IRR RMV: 149700 Exception: Y **N**
 Adjustment(s): GSOIL, IRR Fire Patrol: Description:
 Comments: Liability year - 1980 / 2400210

Site: 4 Code Area: 92410 Size: 2.48 Acres Use Code: 005 Zone: REST SAV Use: 011 Exception: 0
 Class: WOOD **2bd** Value Source: Woodlot Description: FARM WOODLOT RMV: 84950 Exception: Y **N**
 Adjustment(s): GSOIL, IRR Fire Patrol: Description:
 Comments: Liability year - 1980 // 08-09: Market woodlot study by GW39 - change from woodlot to woodlot-M// 2400210

Site: 5 Code Area: 92410 Size: 3.70 Acres Use Code: 005 Zone: REST SAV Use: 011 Exception: 0
 Class: **4B** Value Source: Farm Use - EFU **3.10 AC** Description: FOUR BENCH IRR RMV: 133080 Exception: Y **N**
 Adjustment(s): GSOIL, IRR Fire Patrol: Description:
 Comments: Liability year - 1980

Improvements - Residence / Manufactured Structures

Bldg: 1 Code Area: 92410 Stat Class: 152 + Year Blt: 1977 Eff Year Blt: 1987 Sq.Ft: 3828 % Complete: 100
 Desc: Multi Story above grade Dimensions: RMV: 754520
 Func Obsc: 100 Econ %: 100 Other %: 100 Exception: 0 Adjust: Adjust RMV: 0 **I/O**

Floors

Type	Class	Display Group	Floor Size	Beds	Baths	Yr Blt	Eff Yr Blt	Inventory	Exception
First Floor	5 +	Finished	2694	2	FB-3	1977	1987	BATH - 3, KIT+, ROOF, HVAC+, FP - 13	Y N
Attic	5 +	Finished	1134	1	FB-1	1977	1987	BATH - 1, HVAC+	Y N
Garage Attached	5	Finished	528	0	0	1977	1987	ROOF	Y N

Accessories

Description	Class	Size SqFt	Eff Yr Blt	RMV	Quantity
YARD IMPROVEMENTS AVERAGE	5	1	1987	30996	1

Bldg: 2 Code Area: 92410 Stat Class: 108 Year Blt: 1977 Eff Year Blt: 1977 Sq.Ft: 0 % Complete: 100
 Desc: Residential Other Improvements Dimensions: RMV: 18320
 Func Obsc: 100 Econ %: 100 Other %: 100 Exception: 0 Adjust: Adjust RMV: 0

Floors

Type	Class	Display Group	Floor Size	Beds	Baths	Yr Blt	Eff Yr Blt	Inventory
------	-------	---------------	------------	------	-------	--------	------------	-----------

No floor data available

Accessories

Description	Class	Size SqFt	Eff Yr Blt	RMV	Quantity
ASPHALT DRIVEWAY Keep	1	7800	1977	15015	1

Improvements - Accessory Buildings

Bldg: 3 Code Area: 92410 Stat Class: 353 Year Blt: 1989 Eff Year Blt: 1989 Sq.Ft: 576 % Complete: 100
 Desc: Machine Shed (MS) Dimensions: 36x16 RMV: 1840
 Func Obsc: 100 Econ %: 100 Other %: 100 Exception: 0 Adjust: Adjust RMV: 0

I/O

Floors

Type	Class	Display Group	Floor Size	Beds	Baths	Yr Blt	Eff Yr Blt	Inventory	Exception: Y N
Machine Shed	4	Finished	576	0	0	1989	1989	Fair	N

Accessories

Description	Class	Size SqFt	Eff Yr Blt	RMV	Quantity
No accessory data available					

Bldg: 4 Code Area: 92410 Stat Class: 341 Year Blt: 1989 Eff Year Blt: 1989 Sq.Ft: 240 % Complete: 100
 Desc: Multi Purpose Shed (MP) Dimensions: 20x12 RMV: 1430
 Func Obsc: 100 Econ %: 100 Other %: 100 Exception: 0 Adjust: Adjust RMV: 0

Floors

Type	Class	Display Group	Floor Size	Beds	Baths	Yr Blt	Eff Yr Blt	Inventory	Exception: Y N
Multi-Purpose Bldg	4	Finished	240	0	0	1989	1989		N

Accessories

Description	Class	Size SqFt	Eff Yr Blt	RMV	Quantity
No accessory data available					

Bldg: 5 Code Area: 92410 Stat Class: 351 Year Blt: 1999 Eff Year Blt: 1999 Sq.Ft: 2736 % Complete: 100
 Desc: General Purpose Building (GB) Dimensions: 60x40 RMV: 41070
 Func Obsc: 100 Econ %: 100 Other %: 100 Exception: 0 Adjust: Adjust RMV: 0

2004
 Exterior updates

I/O

Floors

Type	Class	Display Group	Floor Size	Beds	Baths	Yr Blt	Eff Yr Blt	Inventory	Exception: Y N
General Purpose Bldg	6	Finished	2400	0	0	1999	1999	AVG	N
Finished Office	6	Finished	336	0	FB-1	1999	1999	BATH - 1	N

change to excellent pkg

Accessories

Description	Class	Size SqFt	Eff Yr Blt	RMV	Quantity
No accessory data available					

LTL 354 10x60 2024 NEW

MS 353 24x12 2012 NEW



SKETCH/AREA TABLE ADDENDUM

SUBJECT INFO

File No.: 559986 Parcel No.: 063W24B 00100
 Property Address: 2573 Quartz St N
 City: Salem County: Marion State: OR ZipCode: 97303
 Owner:
 Client: Client Address:
 Appraiser Name: Inspection Date:

SKETCH

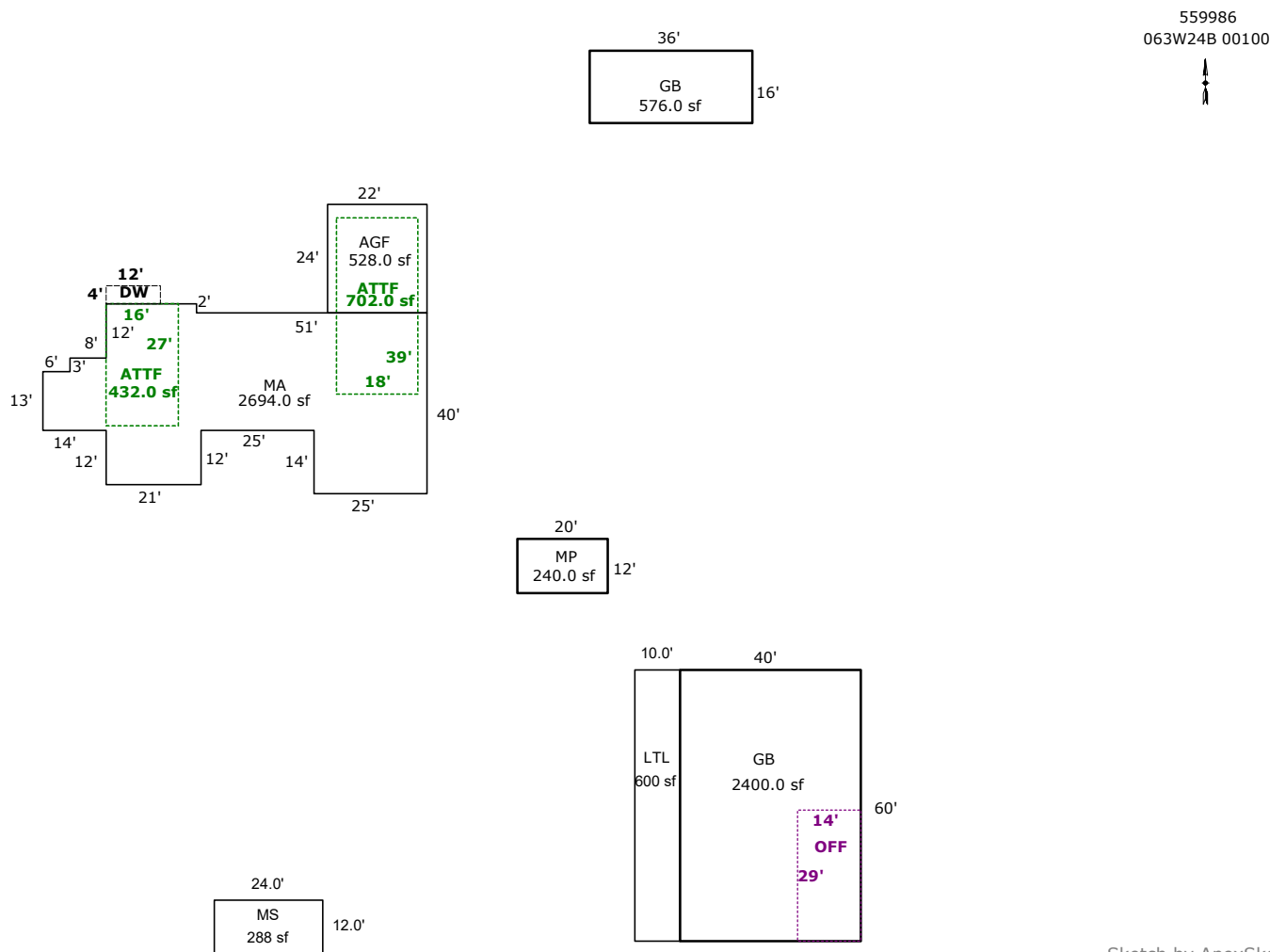

Sketch by ApexSketch

AREA CALCULATIONS SUMMARY						COMMENT TABLE 1	
Code	Description	Factor	Net Size	Perimeter	Net Totals		
GBA1	GB	1.0	576.0	104.0		Apex 2/01/2011 Jane UPDATED BY CLOBERG 10/16/24	
	MP	1.0	240.0	64.0			
	GB	1.0	2400.0	200.0			
	LTL	1.0	600.0	140.0			
	MS	1.0	288.0	72.0	4104.0		
GLA1	MA	1.0	2694.0	278.0	2694.0		
GLA2	ATTF	1.0	702.0	114.0			
	ATTF	1.0	432.0	86.0	1134.0		
GAR	AGF	1.0	528.0	92.0	528.0		
OTH	OFF	1.0	406.0	86.0	406.0	COMMENT TABLE 2	COMMENT TABLE 3
P/P	DW	1.0	48.0	32.0	48.0	GRH 10/11/24	TAGS L2
	Net LIVABLE	cnt	3 (rounded)		3,828		
	Net BUILDING	cnt	5 (rounded)		4,104		

SKETCH/AREA TABLE ADDENDUM

Parcel No R59986

File No 063W24B 00100

SUBJECT

Property Address 2573 Quartz St N

City Salem

State OR

Zip 97303

Owner

Client

Appraiser Name

IMPROVEMENTS SKETCH

R59986
063W24B 00100

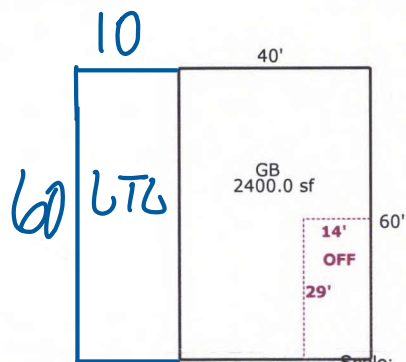
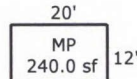
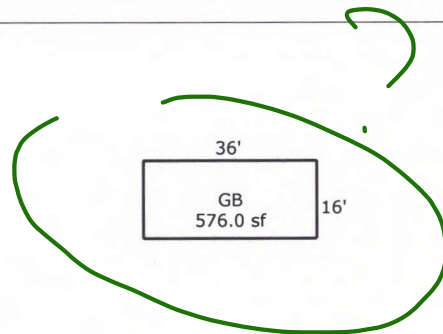
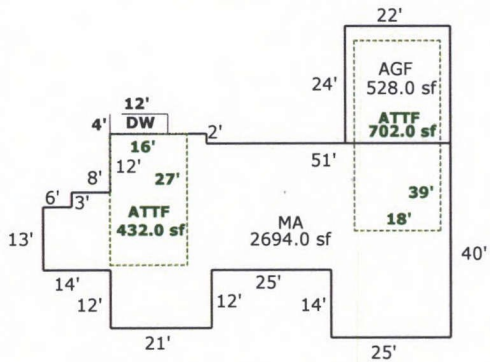

Scale: 1 = 40

Handwritten blue note: **24 MS 12**

AREA CALCULATIONS

AREA CALCULATIONS SUMMARY

Code	Description	Factor	Net Size	Perimeter	Net Totals
GLA1	MA	1.00	2694.0	278.0	2694.0
GLA2	ATTF	1.00	702.0	114.0	
	ATTF	1.00	432.0	86.0	1134.0
SBA1	GB	1.00	576.0	104.0	
	MP	1.00	240.0	64.0	
	GB	1.00	2400.0	200.0	3216.0
GAR	AGF	1.00	528.0	92.0	528.0
P/P	DW	1.00	48.0	32.0	48.0
OTH	OFF	1.00	406.0	86.0	406.0
Net LIVABLE Area		(rounded w/ factors)			3828
Net BUILDING Area		(rounded w/ factors)			3216

Comment Table 1

Apex 2/01/2011 Jane

Comment Table 2

Comment Table 3

Handwritten blue note: **livestock**